



TRI TOOL INC.

TRI TOOL INTERNATIONAL INC.

3806 Security Park Dr., Rancho Cordova, CA 95742-6990 U.S.A. 916-351-0144 800-345-5015 Fax 916-351-0372 ttcustserv@aol.com www.tritool.com

TRI TOOL INC. TECHNICAL SPECIFICATION TRI TOOL AIR CADDYS SEPTEMBER, 2000

AIR CADDY (Part No.'s 75-0078, 75-0086, 75-0114, 75-0115)

Description: Tri Tool's Air Caddys are modular Filter/Regulator/Lubricator's:

1. The filter removes solid and liquid contaminants in compressed air that produces wear in pneumatic equipment.
2. The regulator reduces and holds compressed air to a desired working pressure.
3. The lubricator automatically lubricates pneumatic equipment by introducing small droplets of oil into the airstream.

Specifications:

1. Part No.'s 75-0078, 75-0086, 75-0114 (Heavy Duty)
Reference Envelope Drawing No. 75-0114

Depth:	10.0"	(254mm)
Width:	18.0"	(457.2mm)
Height	17.75"	(450.9mm)
Weight:	29 lbs.	(13.2 Kg)
Flow (max)	331 CFM (100 psi rating)	(156.6 L/s)
Pressure range:	10 to 125 psi	(69 to 861 kPa)

Part No. 75-0086 is used on TRI TOOL Inc. Model 512A1 Panel Saw only.

Part No. 75-0078 is used on all TRI TOOL Inc. equipment with dual air motor configuration.

Part No. 75-0114 is used on all TRI TOOL Inc. equipment with single air motors requiring a flow higher than 165 CFM.

2. Part No. 75-0115 (Standard Duty)
Reference Envelope Drawing No. 75-0015

Depth:	9.50"	(241.3mm)
Width:	12.00"	(304.86mm)
Height	14.50"	(369.5mm)
Weight:	18.2 lbs.	(8.3 Kg)

Copyright© proprietary property of TRI TOOL Inc. No reproduction, use or duplication of the information shown hereon is permitted without the express written consent of TRI TOOL Inc.

Part No. 75-0115 con't.

A. Filter/Regulator Unit:

Flow (max)	165 CFM (100 psi rating)	(78 L/s)
Pressure range:	0 to 125 psi	(0 to 861 kPa)

B. Lubricator Unit:

Flow (max)	200 CFM (100 psi rating)	(94 L/s)
------------	--------------------------	----------

Part No. 75-0115 is used on all TRI TOOL Inc. equipment with single air motor configuration, except units requiring a flow higher than 165 CFM.

Spare parts and standard tool bits are available from stock.

Engineering design services for custom tool bits and special function modifications are available from the factory.

All Tri Tool and allied equipment products are subject to design improvements and specification changes at any time with no obligation to units already sold.

Warranty (limited), parts and/or equipment are warranted against defects in material and workmanship for a period of one year from date of purchase. Full details supplied on request and/or with tools.

Filter, regulator, lubricator required to protect warranty on air powered tool.

NOTE:



This Drawing also used for
P/N 75-0078 & P/N 75-0086

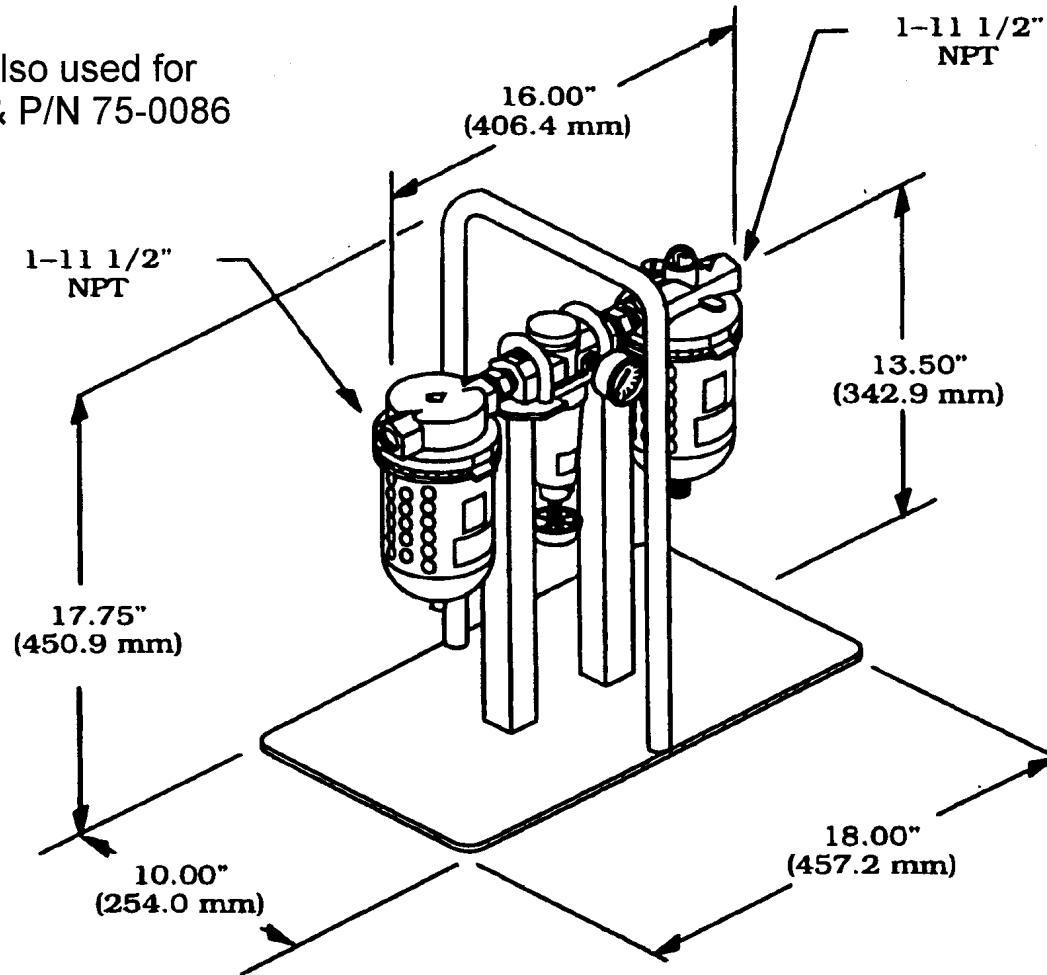

COMPANY CONFIDENTIAL

PROPRIETARY PROPERTY OF TRI TOOL INC.

NO REPRODUCTION, USE, OR DUPLICATION OF THE
DESIGNS SHOWN HEREON IS PERMITTED WITHOUT
EXPRESS WRITTEN CONSENT FROM TRI TOOL INC.

3806 SECURITY PARK DRIVE, RANCHO CORDOVA, CA 95742

COPYRIGHT

TRI TOOL INC.

CONTRACT NO.



TRI TOOL INC

3806 SECURITY PARK DRIVE, RANCHO CORDOVA, CA 95742

APPROVALS	DATE
DRAWN J BROWN	09/08/00
CHECKED	
ISSUED	

ENVELOPE DRAWING
AIR CADDY ASSEMBLY, HEAVY DUTY

SIZE A	SOLID WORKS AVAILABLE	DWG. NO. 75-0114	REV.
SCALE 1/1	CAD MODEL	SHEET 1 OF 1	

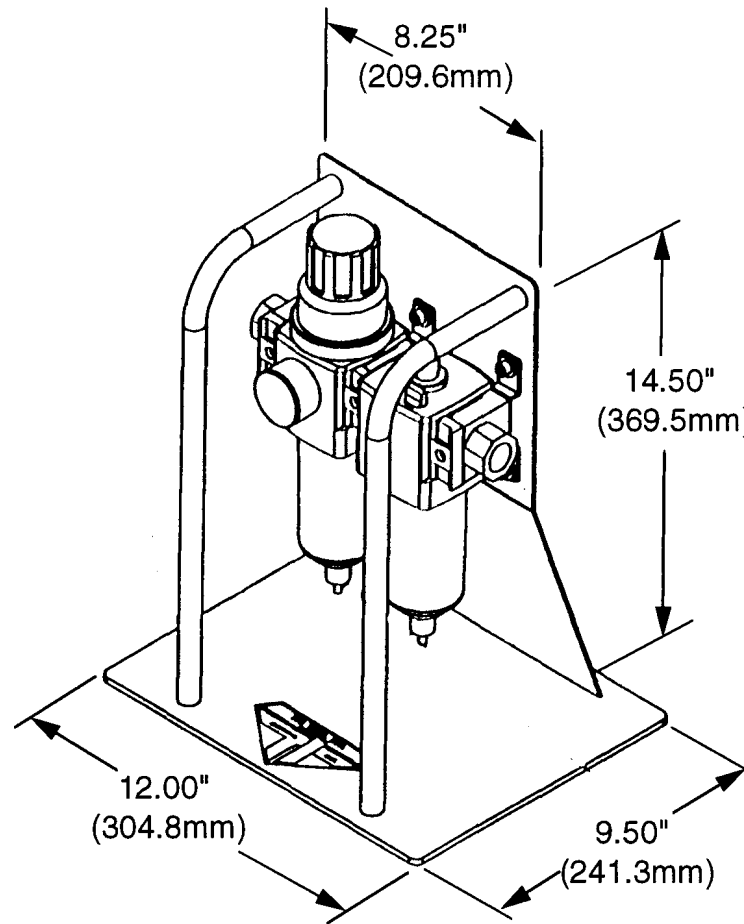

COMPANY CONFIDENTIAL
 PROPRIETARY PROPERTY OF TRI TOOL INC.
 NO REPRODUCTION, USE, OR DUPLICATION OF THE
 DESIGNS SHOWN HEREON IS PERMITTED WITHOUT
 EXPRESS WRITTEN CONSENT FROM TRI TOOL INC.

3808 SECURITY PARK DRIVE, RANCHO CORDOVA, CA 95742
 COPYRIGHT TRI TOOL INC.

CONTRACT NO.

APPROVALS	DATE
DRAWN J BROWN	09/08/00
CHECKED	
ISSUED	



TRI TOOL INC

3808 SECURITY PARK DRIVE, RANCHO CORDOVA, CA 95742

ENVELOPE DRAWING

AIR CADDY ASSEMBLY, STANDARD DUTY

SIZE A	SOLID WORKS AVAILABLE
------------------	--------------------------

DWG. NO.	75-0115
----------	----------------

REV.	
------	--

SCALE	1 / 1
-------	-------

ICAD MODEL	
---------------	--

SHEET	1 OF 1
-------	--------