



TRI TOOL INC.

TRI TOOL INTERNATIONAL INC.

3806 Security Park Drive, Rancho Cordova, CA 95742-6990 U.S.A. 916-351-0144, 800-345-5015 FAX 916-351-0372 ttcustserv@aol.com www.tritool.com

TRI TOOL INC. TECHNICAL SPECIFICATION MODEL 624RBL LOW PROFILE CLAMSHELL SEPTEMBER, 1999

MODEL 624RBL Low Profile Clamshell

Description: The 624RBL Low Profile Clamshell is a split-frame pipe lathe for severing and/or beveling in-line pipe with a range of 18" through 24" nominal diameter with minimal radial and axial clearances.

Design and Operating Features

1. Easily adjustable precision 90° -Vee bearings preload and stabilize the rotating head to provide long life, low maintenance, stability and precision.
2. The clamshell splits into two halves for mounting on closed looped systems. All parts are secured to the two halves to avoid loss of parts and provide maximum ease of handling.
3. The clamshell is equipped with jackscrews and adjustable mounting pads for out-of-round pipe conditions.
4. Dual tool modules with auto-feed star wheels and adjustable slide ways provide maximum maintainability, life and operator safety with minimum operator training.
5. The gear reduction, auto-feed star wheels provide .0025" (.06mm) of radial feed per revolution for a controlled depth of cut.
6. Drive gears and bearing surfaces are covered for operator safety and sealed to prevent cutting chip damage.
7. Operator controls are away from the rotating head for operator safety.
8. Modular design concepts provide quick, easy maintenance and maximum versatility in drive and tooling options.
9. The clamshell has 90° -Vee bearings that are field adjustable back to zero tolerance.

Specifications

1. Reference Envelope Drawing No. 77-1314, 77-1352.
2. Cutting capacities* 18" through 24" pipe: with std. tool modules:
 - a. Severing with standard procedures 2.50" (63.5mm) wall
 - b. Severing and single beveling 1.00" (25.4mm) wall
 - c. Severing and double beveling 1.00" (25.4mm) wall
 - d. Severing and beveling w/ special procedures 2.00" (50.8mm) wall

* Materials include, but are not limited to: carbon steel, low alloy steel, chrome steel (20% max.), chrome / molly alloys (Rc 32 max.), austenitic stainless steel, inconel, copper, aluminum and copper nickel alloys.

3. Clearances: (see Envelope drawings)
4. Drive Options:
 - a. Single or dual right angle air motors:
Single air requirements @ 90 PSI (6.3 kg/cm²) 80 CFM (38 lt/sec)
Head Speed @ maximum horsepower 5 RPM
 - b. Single or dual inline hydraulic motors
(requires separate hydraulic power supply. Ref: 765RVC technical specifications)
 - c. Single Heavy Duty electric motor. Ref: Dwg. 77-1418

5. Tool Modules:
 - a. Working diameter range 18" - 24 " pipe
 - b. Feed rate .0025" (.06mm)/rev

6. Mounting:

4 fully adjustable mounting pads with additional mounting jackscrews for 18" , 20", 22", and 24" pipe.

7. Approximate weights:

Basic machine w/ 2 drive housings	171lbs. (77.6kg)
Standard Tool Modules	18 lbs. (8.2kg) /module
Hydraulic Motors	34 lbs. (15.4 kg) ea.
Air Motors	19 lbs. (8.6 kg) ea.
Electric Motor - Heavy Duty	30 lbs. (13.6kg)

Spare parts and standard tool bits are available from stock.

Engineering design services for custom tool bits and special function modifications are available from the factory.

All Tri Tool and allied equipment products are subject to design improvements and specification changes at any time with no obligation to units already sold.

Warranty (limited), parts and/or equipment are warranted against defects in material and workmanship for a period of one year from date of purchase. Full details supplied on request and/or with tools.

Filter, regulator, lubricator required to protect warranty on air powered tools.

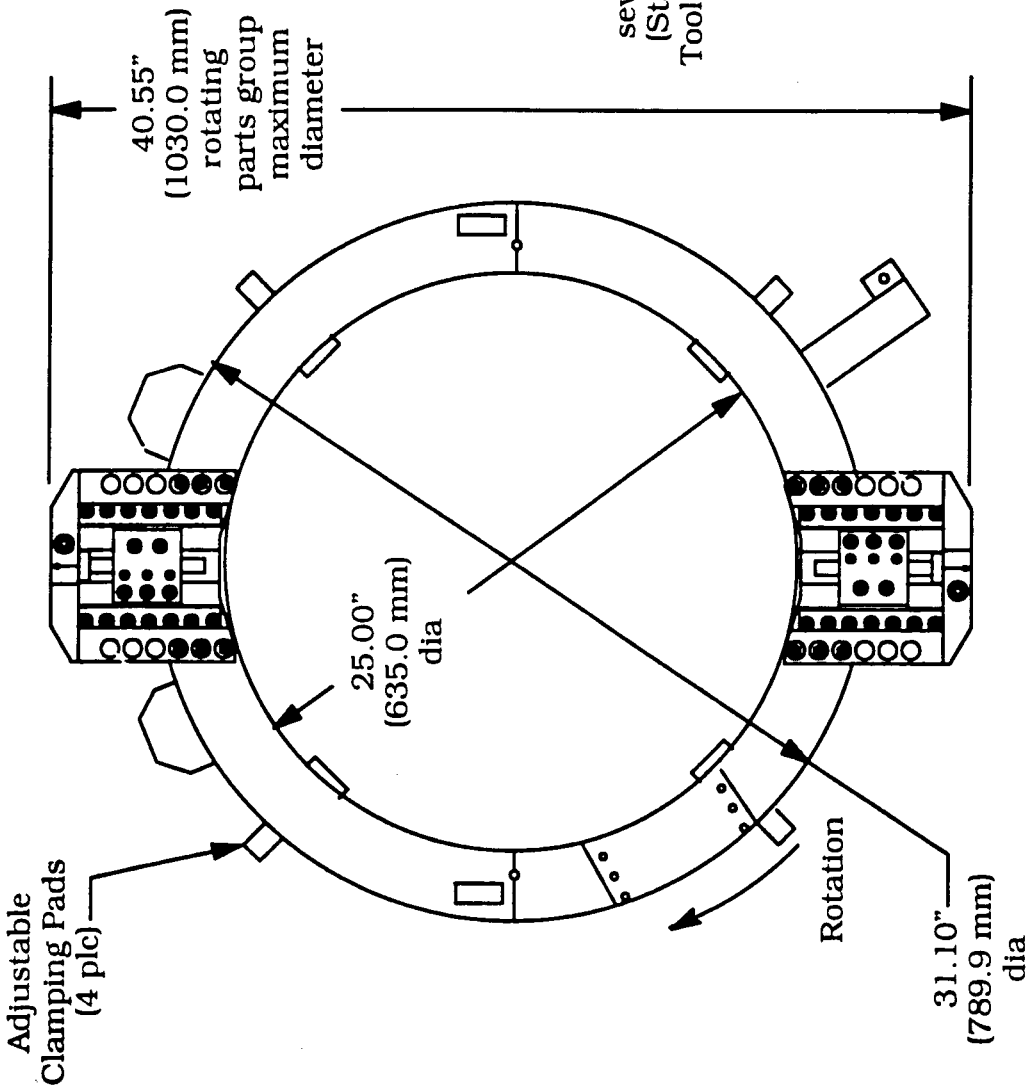

CONTRACT NO.		DATE	
APPROVALS	PFAFMAN	12/09/93	
DRAWN	Bk	01/05/95	
CHECKED			
ISSUED			
DO NOT SCALE DRAWING			

COMPANY CONFIDENTIAL
 PROPRIETARY PROPERTY OF TRI TOOL INC.
 NO REPRODUCTION, USE, OR DUPLICATION OF THE
 DESIGNS SHOWN HEREON IS PERMITTED WITHOUT
 EXPRESS WRITTEN CONSENT FROM TRI TOOL INC.
 3806 SECURITY PARK DRIVE, RANCHO CORDOVA, CA 95742 6890
 COPYRIGHT TRI TOOL INC.

TRI TOOL INC.
 3806 SECURITY PARK DRIVE RANCHO CORDOVA, CA 95742-6890

Envelope Drawing
 Model 624RBL Clamshell, Hyd

SIZE **A** FSCM NO. DWG. NO. **77-1314** REV.

SCALE None SHEET 1 of 1

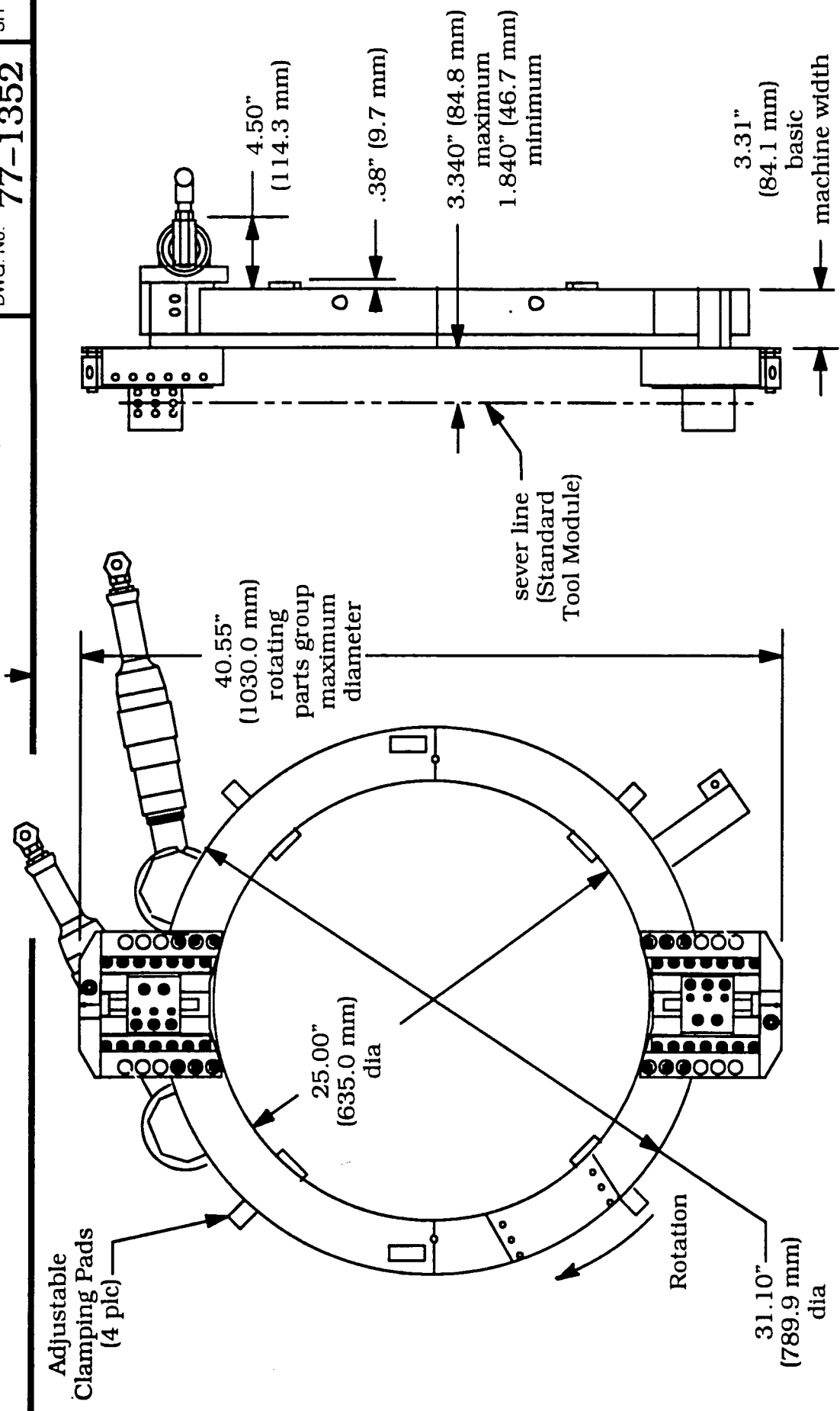

 TRI TOOL INC. 3806 SECURITY PARK DRIVE, RANCHO CORDOVA, CA 95742-6990		Envelope Drawing Model 624RBL Clamshell, Air		REV.
CONTRACT NO.	APPROVALS	DATE	FSCM NO.	DWG. NO. 77-1352
	DRAWN PFAFMAN	12/09/93		
	CHECKED Bld	01/05/95		
	ISSUED			
DO NOT SCALE DRAWING			SCALE None	SHEET 1 of 1

COMPANY CONFIDENTIAL
 PROPRIETARY PROPERTY OF TRI TOOL INC.
 NO REPRODUCTION, USE, OR DUPLICATION OF THE
 DESIGNS SHOWN HEREON IS PERMITTED WITHOUT
 EXPRESS WRITTEN CONSENT FROM TRI TOOL INC.
 3806 SECURITY PARK DRIVE, RANCHO CORDOVA, CA 95742-6990
 TRI TOOL INC.
 COPYRIGHT

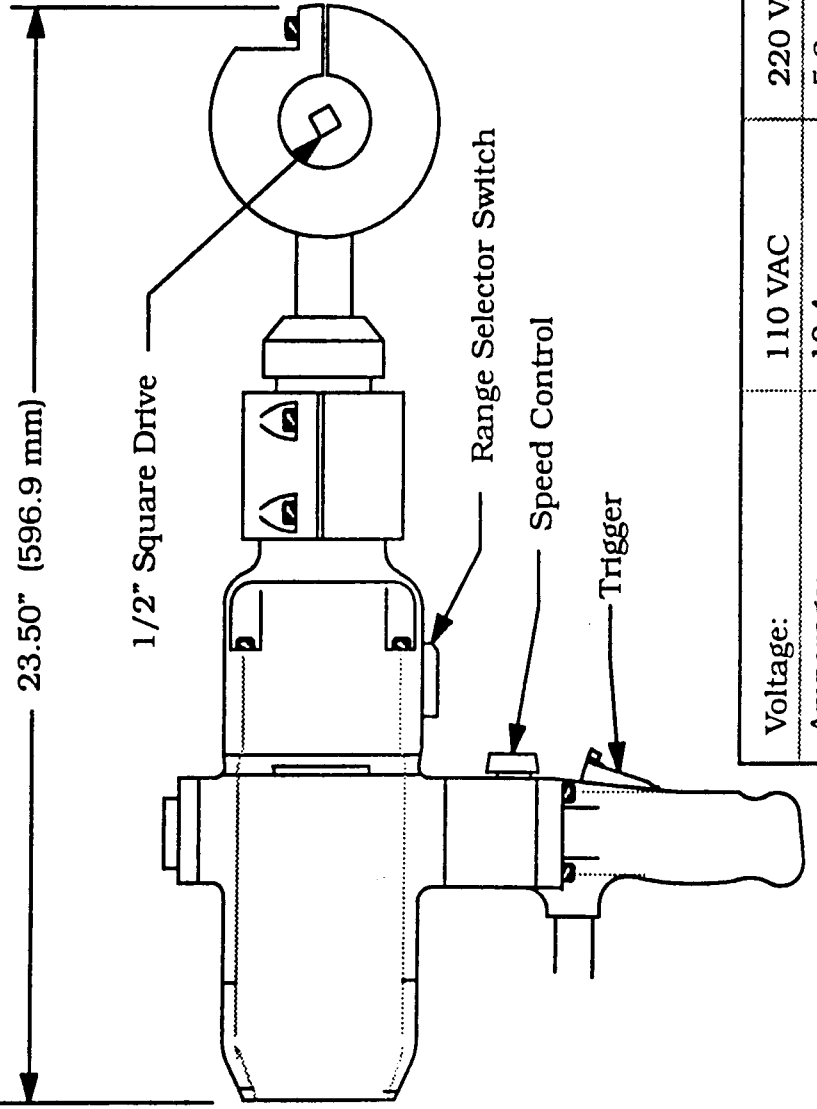
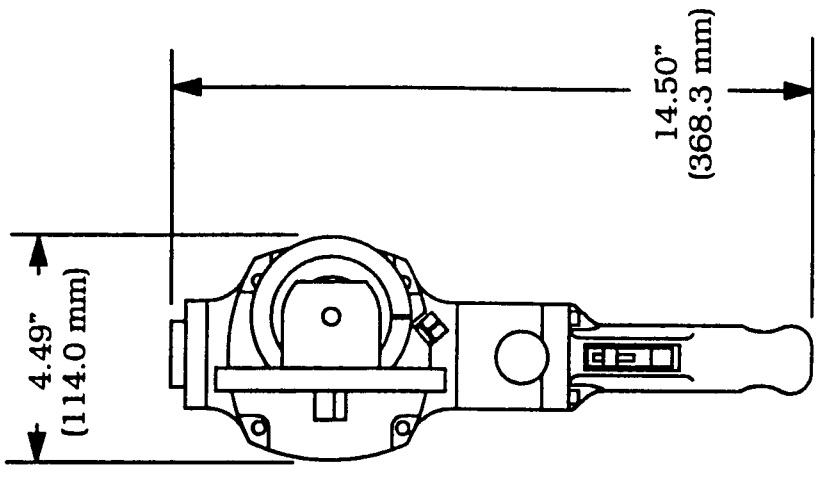

Voltage:	110 VAC	220 VAC
Amperage:	10.4 amps	5.2 amps
Wattage:	1050 watts	1050 watts
Speed, full load (rpm):	79-132/157-264	
Speed, no load (rpm):	86-193/171-386	



TRI TOOL Inc.
3806 SECURITY PARK DRIVE RANCHO CORDOVA, CA 95742-6990

Envelope Drawing
Electric Motor for the 600RBLs

SIZE **A** FSCM NO. DWG. NO. **77-1418** REV.

CONTRACT NO.		DATE	
APPROVALS			
DRAWN	PFAFMAN		3/7/95
CHECKED			
ISSUED			
DO NOT SCALE DRAWING		SCALE	None

COMPANY CONFIDENTIAL
PROPRIETARY PROPERTY OF TRI TOOL INC.
NO REPRODUCTION, USE, OR DUPLICATION OF THE
DESIGNS SHOWN HEREON IS PERMITTED WITHOUT
EXPRESS WRITTEN CONSENT FROM TRI TOOL INC.
3806 SECURITY PARK DRIVE RANCHO CORDOVA, CA 95742-6990
COPYRIGHT TRI TOOL INC.