



TRI TOOL INC.

TRI TOOL INTERNATIONAL INC.

3806 Security Park Drive., Rancho Cordova, CA 95742-6990 U.S.A. 916-351-0144 800-345-5015 FAX 916-351-0372 ttcustserv@aol.com www.tritool.com

TRI TOOL INC.
TECHNICAL SPECIFICATION
MODEL 404 KEYMASTER™
OCTOBER, 1999

MODEL 404 KEYMASTER™

The Model 404 KEYMASTER™, is a keyway cutter designed to mill 1/4" (6.35mm) to 1 1/4" (31.75mm) wide by up to 6" (152.4mm) long keyway slots in 1 1/2" (38.1mm) to 4 1/2" (114.3mm) diameter shafts. The cutter may be used to install new keyways, re-cut keyways after being weld repaired, or install second keyways to bypass a damaged keyway. The tool uses a Vee block system to auto align and center the tool to the shaft. The tool mounts with a fixed bottom clamp bar. For larger shaft sizes a system of spacers and chain clamps are available. The tool incorporates a graduated depth of cut system and a mechanism to shift the cutter off center to allow milling the sides of a keyway with a light finish cut for optimum width precision and surface finishes. With this system the keyway width is not dependent on the mill cutter dimensions, i.e. a 3/8" (9.53mm) mill cutter can be used to cut up to a 5/8" (15.88mm) wide key slot. Provisions are incorporated to allow use of a dial indicator for adjustments and to verify the setting accuracy. Axial feed is provided for with a manual ratchet system. The Model 404 uses standard 1/2" (12.70mm) dia. shank mill cutters. The standard drive motor is a variable speed 1 HP 115 Volt AC motor.

Design and Operating Features

1. Vee base mounting for precision alignment to the axis of the shaft.
2. Adjustable steel gibs for axial travel slide system.
3. 4130 steel lead screw and brass lead screw nut in the axial travel slide.
4. Precision bull pin centers the Y axis adjustment to establish the center line cut.
5. Positive locking on the Y axis off-set system.
6. Down feed for depth of cut setting graduated in 0.002" (.050mm) increments.
7. Worm Gear final spindle drive for smooth power delivery.
8. Tapered Roller bearings in the spindle.

Specifications

1. Axial shaft required for clamp length: 1" (25.4mm)
2. Shaft Diameter Range: 1 1/2" (38.1mm) to 4 1/2" (114.3mm)
3. Motor Power Requirements: Variable speed, 1HP, 115VAC, 10.2 Amps
4. Speed Control: Variable speed control in motor
5. Spindle Speed: 0 – 560 RPM
6. Weight: 61 lbs. (27.67kg)
7. Axial Feed Travel 5 1/2" (139.7mm)
8. Vertical Feed Travel 2" (50.8mm)

Power Drive Options:

1. The Model 404 can be supplied with a pneumatic motor or a 230 VAC, 50/60 Hz electric motor.

Optional Accessories:

4" – 24" Range Extension Kit

Endmill Kit

Dial Indicator Assembly

Carrying Case

Spare parts and standard tool bits are available from stock.

Engineering design services for custom tool bits and special function modifications are available from the factory.

All Tri Tool and allied equipment products are subject to design improvements and specification changes at any time with no obligation to units already sold.

Warranty (limited), parts and/or equipment are warranted against defects in material and workmanship for a period of five years from date of purchase. Full details supplied on request and/or with tools.

Filter, regulator, lubricator required to protect warranty on air powered tools.

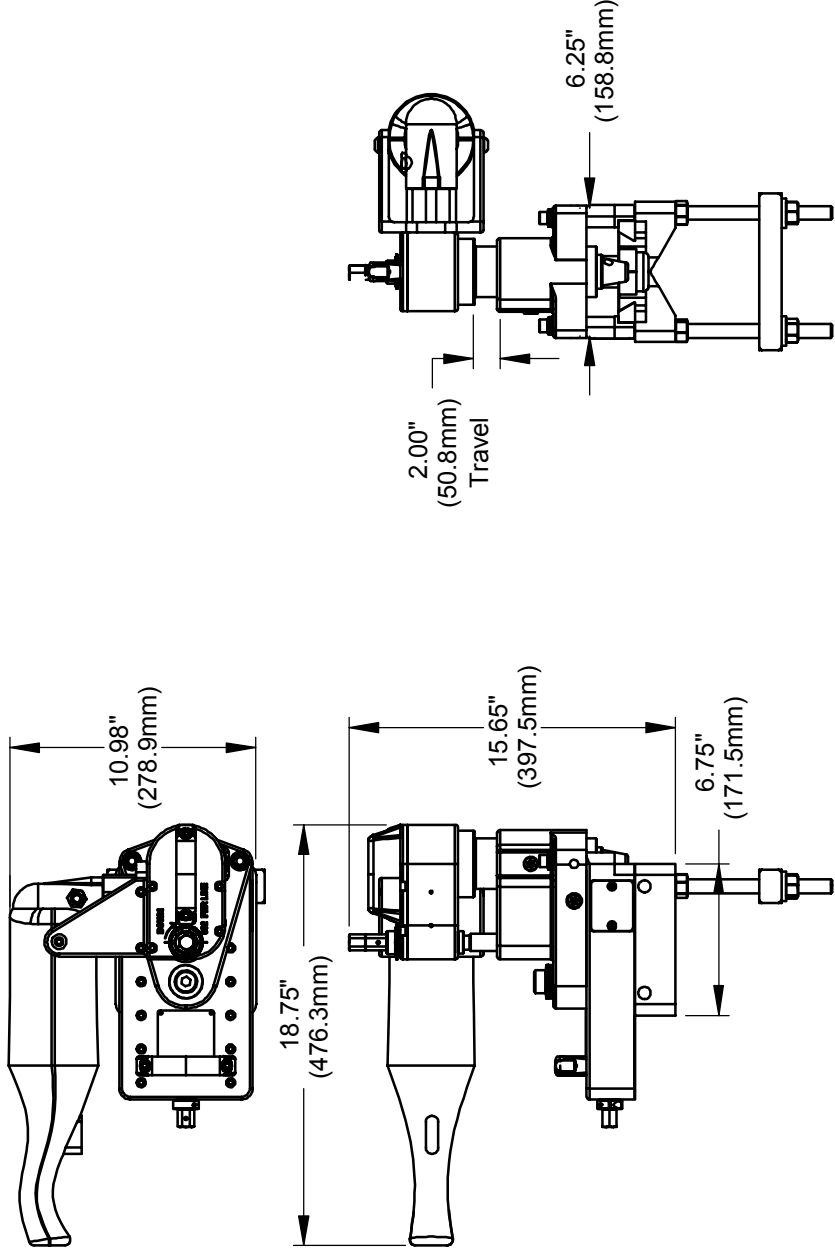

COMPANY CONFIDENTIAL PROPRIETARY PROPERTY OF TRI TOOL INC. NO REPRODUCTION, USE, OR DUPLICATION OF THE DESIGNS SHOWN HEREON IS PERMITTED WITHOUT EXPRESS WRITTEN CONSENT FROM TRI TOOL INC. 3806 SECURITY PARK DRIVE, RANCHO CORDOVA, CA 95742 COPYRIGHT TRI TOOL INC.		CONTRACT NO. ER-8157		 TRI TOOL INC 3806 SECURITY PARK DRIVE, RANCHO CORDOVA, CA 95742		
		APPROVALS DRAWN J Brown CHECKED ISSUED	DATE 042299	Model KEYMASTER™ ENVELOPE DRAWING		SIZE A
		SCALE	CAD MODEL	SHEET 1 OF 1		