



TRI TOOL INC.

TRI TOOL INTERNATIONAL INC.

3806 Security Park Drive, Rancho Cordova, CA 95742-6990 U.S.A. 916-351-0144, 800-345-5015 FAX 916-351-0372 ttcustserv@aol.com www.tritool.com

TRI TOOL INC.
TECHNICAL SPECIFICATION
MODEL 224B I.D. TRACKING MODULE
JUNE, 1999

MODEL 224B I.D. Tracking Module

The Model 224B I.D. Tracking Module is an optional accessory which increases the versatility of the 224B BEVELMASTER™. The I.D. tracking module is designed to track out of round pipe where control of the land thickness is critical.

The 224B I.D. Tracking Module comes complete with:

- a. I.D. Tracking Module Assembly
- b. All required operator's wrenches
- c. Operator's manual

Design and Operating Features:

1. Easy to assemble unit bolts directly to the Model 224B in lieu of the standard tool modules.
2. 1" (25.4mm) of radial tool holder spring travel accommodates pipes that are out of round.
3. The tool holder has two tool bit slots to allow facing and beveling simultaneously.

Specifications:

1. Reference Envelope Drawing No. 77-1622.
2. Pipe sizes:
12" – SCD 80 through 24" pipe.
3. Radial Tracking Travel:
1" (25.4mm)

Spare parts and standard tool bits are available from stock. Engineering design services for custom tool bits and special function modifications are available from the factory.

All Tri Tool and allied equipment products are subject to design improvements and specification changes at any time with no obligation to units already sold.

Warranty (limited), parts and/or equipment are warranted against defects in material and workmanship for a period of one year from date of purchase. Full details supplied on request and/or with tools.

Filter, regulator, lubricator required to protect warranty on air powered tools.

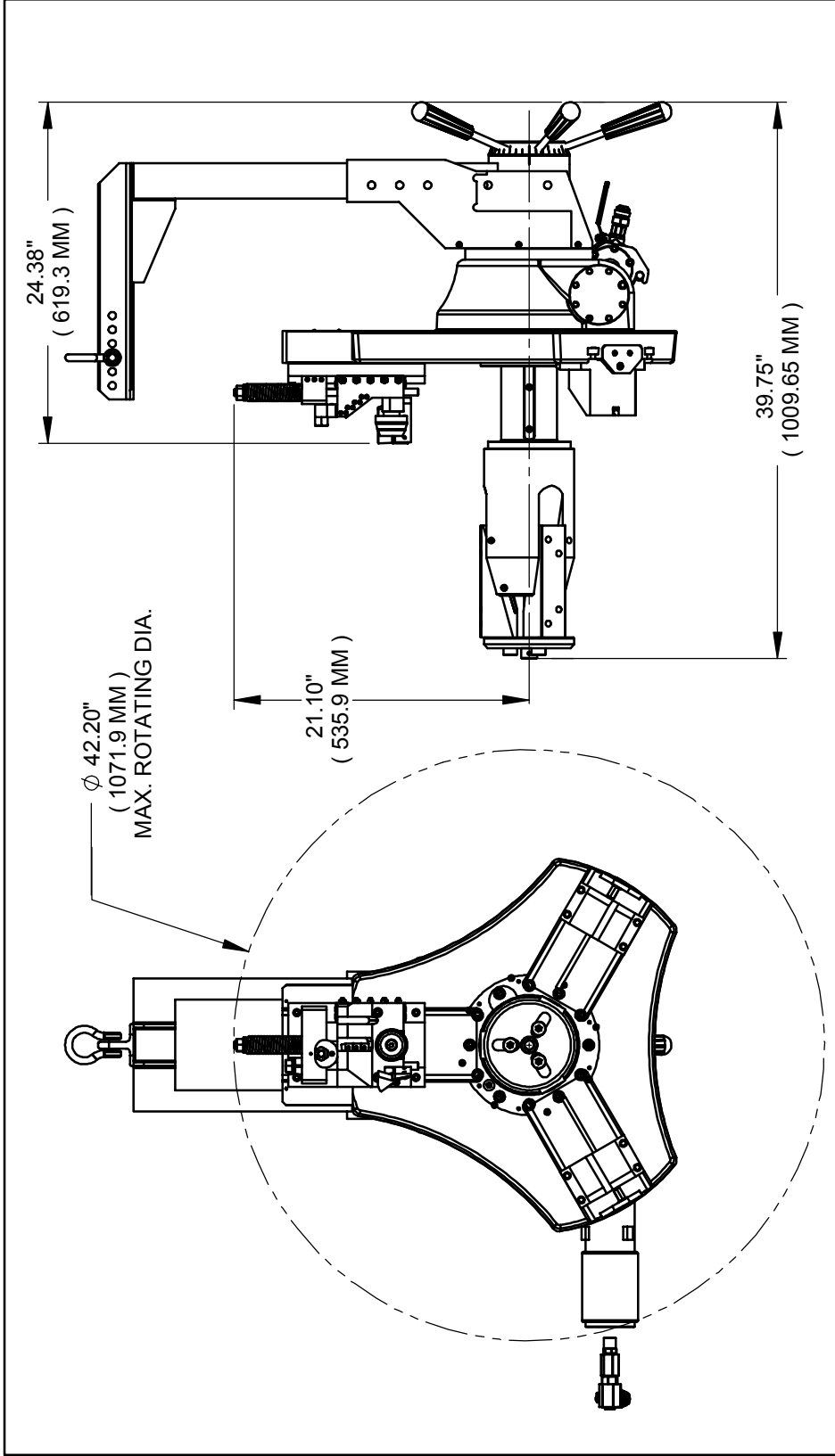

COMPANY CONFIDENTIAL PROPRIETARY PROPERTY OF TRI TOOL INC. NO REPRODUCTION, USE, OR DUPLICATION OF THE DESIGNS SHOWN HEREON IS PERMITTED WITHOUT EXPRESS WRITTEN CONSENT FROM TRI TOOL INC. 3806 SECURITY PARK DRIVE, RANCHO CORDOVA, CA 95742 COPYRIGHT TRI TOOL INC.		CONTRACT NO. ER-8138		 TRI TOOL INC 3806 SECURITY PARK DRIVE, RANCHO CORDOVA, CA 95742	
APPROVALS	DATE	ENVELOPE DRAWING 224B-I.D. TRACKING MODULE		SIZE	REV.
DRAWN TIMBERLAKE	6/28/99			A	
CHECKED				SOLID WORKS AVAILABLE	77-1622
ISSUED				SCALE	NONE
				CAD MODEL	224B ENV.SLDPRT
					SHEET 1 OF 1