



TRI TOOL INC.

TRI TOOL INTERNATIONAL INC.

3806 Security Park Dr., Rancho Cordova, CA 95742-6990 U.S.A. 916-351-0144 800-345-5015 Fax 916-351-0372 ttcustserv@aol.com www.tritool.com

TRI TOOL INC. TECHNICAL SPECIFICATION MODEL 204B BEVELMASTER™ SYSTEM FEBRUARY, 2000

MODEL 204B BEVELMASTER™ PORTABLE LATHE SYSTEM

The Model 204B BEVELMASTER™ is a portable I.D. mount machine tool for beveling, facing and counterboring the ends of pipe or tubing in preparation for welding. Special features include:

Mandrel shaft heat treated to Rc 50 for maximum strength and to minimize wear damage.

Heavy duty tapered mandrel and spindle bearings.

Mandrel shaft seal to keep coolants out of the gears.

Heat treated mandrel mounting blocks for maximum life and secure mounting.

Heavy duty air motor and gear reduction for optimum performance.

The Model 204B BEVELMASTER™ will secure to pipe and tubing having an inside diameter ranging from 1.25" (31.8mm) through 4.33" (110.0mm).

The Model 204B BEVELMASTER™ System comes complete with:

- A. Model 204B Subassy
- B. Head Kit, 4" Dia. w/cam
- C. Air Motor Assy.
- D. Mandrel Assy.
- E. Jaw Block Set
- F. Wrench Kit
- G. Carrying Case
- H. Operator's Manual

Optional Accessories:

Mandrel Assy., Reduced Dia., 1.00" (25.4mm) to 1.25" (31.8mm) range.
Mandrel Assy., Reduced Dia., .610" (15.5mm) to 1.00" (25.4mm) range.
Flange Facer Kit
Elbow Mandrel Kit

Pointer Kit, Elbow Mandrel
Mandrel Assy., Small Elbow
Air Caddy, FRL.

Design and Operation Features:

1. The lathe accepts it's own torque through the mandrel.
2. The expanding mandrel provides fast, accurate self-centering and alignment.
3. All wrenches needed for operation(less Tool Bits) are provided with the system.
4. The lathe [at less then 18 lbs. (8.16 Kg)] is lightweight and is easily handled by one operator.

Specifications:

1. Reference Envelope Drawing No.77-1557
2. Pipe Cutting Capacities:
 - a. Basic Pipe sizes:
All schedules of 1 1/4" through 4" pipe.
Some schedules may require optional equipment.
 - b. Basic Tube Size:
Up to .531" (13.5mm) wall tubing with a maximum O.D. of 4.50" (114.3mm) and a minimum I.D. of 1.25" (31.7mm) may be beveled with standard mandrel.
 - c. Wall Thickness Capacity:
Wall thickness of all standard pipe schedules [.531" (13.5mm) maximum] in the range listed. Contact Tri Tool for heavier wall procedures.
 - d. Counterboring Operations:
The tool will counterbore pipe and tubing with an I.D. range of 1.50" (38.1mm) to 4.33" (110.2mm).
3. Material Cutting Capabilities:
 - a. Mild steels, Chrome steels (Rc 35 max), stainless steel, copper-nickel alloys and aluminum without limitations except size and wall thickness as specified in paragraph #2.
 - b. Inconel and some other high temperature alloys may require special procedures as a function of wall thickness and type of end preparation. Contact Tri Tool's Engineering Department for details.
4. Clearance and dimensions:

- a. Rotating Head Dia. 4.00" (101.6mm)
- b. Length over motor: 19.88" (505.0mm)
- c. Length (of machine) 8.97" (227.8mm)
- d.. Available feed travel: 1.50" (38.1mm)

5. Drive System:

- a. Final Drive: Gear Driven
- b. Pneumatic Motor:
 - Free speed 325 rpm
 - Max. H.P. speed 162 rpm

6. Power Supply:

- a. Pneumatic motor requires 55 cfm (26 L/s) air supply at 90 psi (621 kPa) for maximum horsepower delivery.

Note: Air Supply must have a filter/regulator/lubricator (FRL) system to protect the warranty on the air motor.

7. Cutting Head Speeds:

- a. Maximum Cutting head speed: 162 rpm
- b. Cutting head speed @ maximum H.P. 82 rpm
- c. Functional speed range: 20-100 rpm
- d. RPM at 300 surface inches per minute:
 - 4.50" (114.3mm) 21 rpm
 - 1.25" (31.8mm) 76 rpm

8. Speed Control:

- a. On/off safety lever valve and twist-type air flow control valve.

9. Mounting:

- a. Manually actuated draw rod expands mandrel ramps and jaw blocks.

10. Feed:

- a. Manual-Feed Handle is in line at the back of the machine. Feed rate is .100" (2.5mm) per revolution of the feed handle.

Spare parts and standard tool bits are available from stock.

Engineering design services for custom tool bits and special function modifications are available from the factory.

All Tri Tool and allied equipment products are subject to design improvements and specification changes at any time with no obligation to units already sold.

Warranty (limited), parts and/or equipment are warranted against defects in material and workmanship for a period of one year from the date of purchase. Full details supplied on request and/or with tools.

Filter, regulator, lubricator are required to protect warranty on air powered tools.

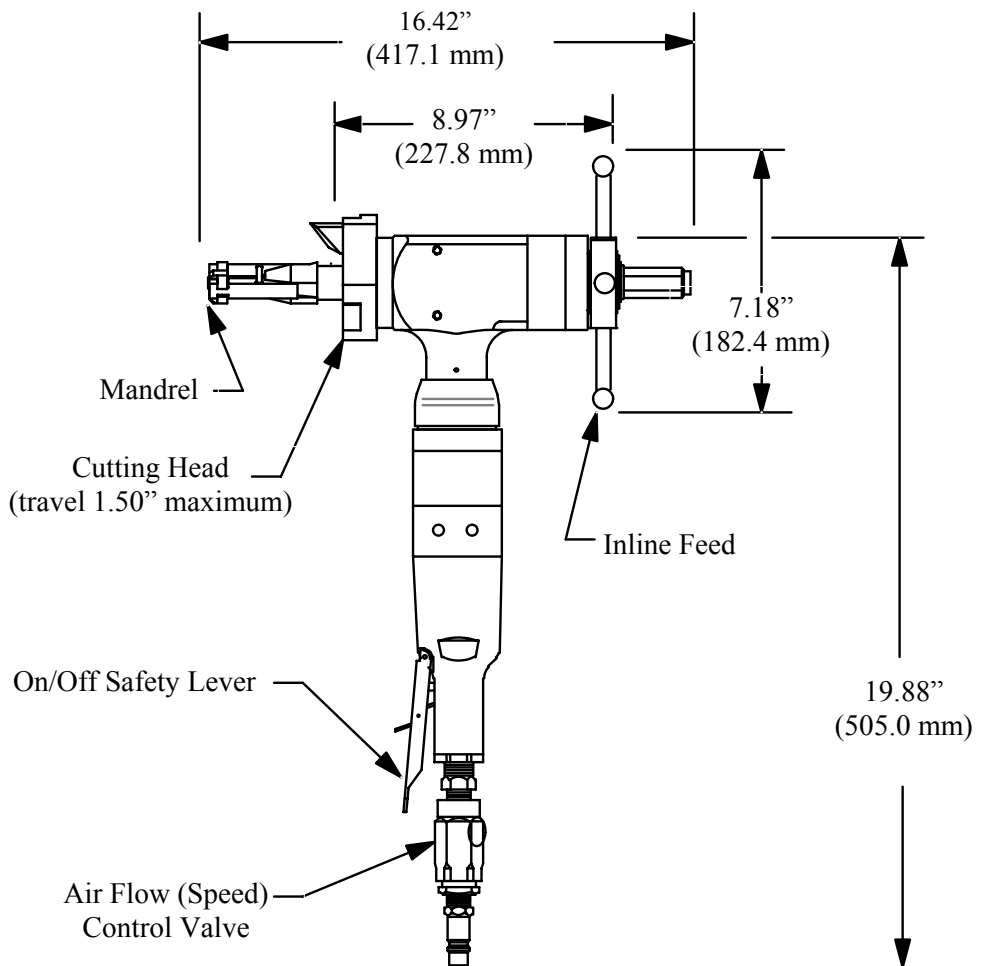
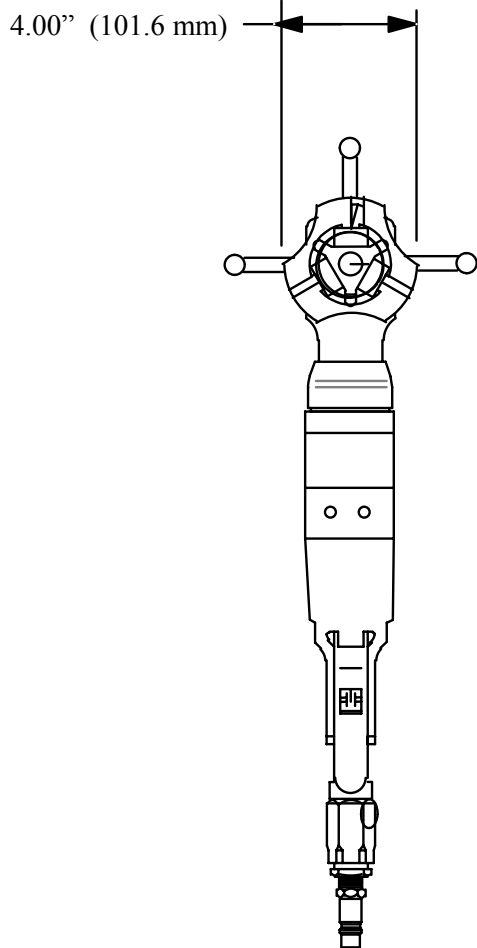

COMPANY CONFIDENTIAL
 PROPRIETARY PROPERTY OF TRI TOOL INC. NO REPRODUCTION, USE OR DUPLICATION OF THE DESIGNS SHOWN HEREON IS PERMITTED WITHOUT EXPRESS WRITTEN CONSENT FROM TRI TOOL INC., 3806 SECURITY PARK DRIVE, RANCHO CORDOVA, CA 95742-6990
 COPYRIGHT

APPROVALS	DATE
DRAWN PFAFMAN	4/28/97
CHECKED	
DO NOT SCALE DRAWING	



TRI TOOL INC.
 3806 SECURITY PARK DRIVE
 RANCHO CORDOVA, CA 95742-6990

Envelope Drawing
Model 204B BEVELMASTER™

	DWG NO. 77-1557	REV
Scale: None	SHEET 1 of 1	

