

TABLE OF CONTENTS

CUSTOMER MESSAGE	Inside Front Cover
SAFETY PRECAUTIONS	3
GENERAL DESCRIPTION	6
SPECIFICATIONS	7
MAINTENANCE	13
OPERATION	16
CUTTING SPEEDS AND FEEDS	21
JAW BLOCKS, RAMPS AND	23
TOOL BITS	27
TROUBLE SHOOTING	30
ACCESSORIES	32
ILLUSTRATED PARTS BREAKDOWN	33
TOOL BIT RESHARPENING POLICY	Inside Back Cover
WARRANTY INFORMATION	Inside Back Cover

Copyright 2008
Proprietary property of TRI TOOL Inc.
No reproduction, use, or duplication of the information
shown hereon is permitted without the express written
consent of TRI TOOL Inc.

SAFETY PRECAUTIONS

IN GENERAL

When using rotating head cutting equipment, basic safety precautions should always be followed to reduce the risk of personal injury.

Operate this tool only in accordance with specific operating instructions.

WARNING:

Do not override the deadman switch on the power unit. Locking down, obstructing, or in any way defeating the deadman switch on the power drive unit may result in serious injury.

DRESS CONSIDERATIONS

Use standard safety equipment. Hard hats, safety shoes, safety harnesses, protective clothes, and other safety devices should always be used when appropriate.

Use safety glasses. Do not operate cutting tools without eye protection.

Dress properly. Do not wear loose clothing or jewelry. They can be caught in rotating and moving parts. Avoid slippery floors or wear nonskid footwear. If you have long hair, wear protective hair covering to contain it.

WORK AREA

Keep the work area clean. Cluttered work areas and benches invite injuries.

Consider the work area environment. Keep the area well lit. Keep electrical cords, cables, rags, rigging straps, and etc. clear of rotating equipment. Do not use power-cutting tools in the presence of flammable liquids and gasses.

Keep visitors away. Do not let visitors or untrained personnel at or near operating tools. Enforce eye protection requirements for all observers.

Do not over reach. Keep proper footing at all times.

Stay alert. Watch what you are doing. Use common sense. Do not operate tools when you are tired.

TOOL CARE

Maintain tools with care. Keep tools in good operating condition. Sharp tool bits perform better and safer than dull tool bits. Well maintained tools function properly when needed.

Check for damaged parts. If a tool has malfunctioned, been dropped or hit, it must be checked for damage. Run no-load tests and feed function checks. Do a complete visual inspection.

Electric motors. Use only with proper AC voltage power sources and observe all normal electric shock hazard procedures.

Do not abuse power and control cords. Pulling or running over cords and cables can result in electrical shock hazards and malfunctions. Keep control and power cords out of all cutting fluids and water.

Hydraulic drives. Observe proper procedures for electrically driven power sources. Avoid damage to hydraulic lines. Keep quick-disconnects clean. Grit contamination causes malfunctions.

Air tools. Check the exhaust muffler. Broken or damaged mufflers can restrict air flow or cause excessive noise. Use air motors only with a filtered, lubricated and regulated air supply. Dirty air, low-pressure air or over pressure air will cause malfunctions, including delayed starting.

AREA EQUIPMENT

Secure work. Whenever possible use clamps, vises, chains and straps to secure pipe.

Make sure the tool is secured; it is safer to have both hands free to operate the tool.

TOOL USE

Use the right tool and tool bit for the job. Do not use a tool, which is incorrect for the job you are doing.

Keep the tool bits fully engaged in the tool bit holders. Loose bits are a safety hazard.

Disconnect power supply during setup and maintenance. Use all 'Stop' or Shut off' features available when changing or adjusting tool bits, maintaining the tool, or when the tool is not in use.

Remove adjusting keys and wrenches before applying power to the equipment. Develop a habit of checking the tool before turning it on to make sure that all keys and wrenches have been removed.

Do not force tools. Tools and tool bits function better and safer when used at the feed and speed rate for which they were designed.

Do not reach into rotating equipment. Do not reach into the rotating head stock to clear chips, to make adjustments, or to check surface finish. A machine designed to cut steel will not stop for a hand or an arm.

Handle chips with care. Chips have very sharp edges and are hot. Do not try to pull chips apart with are hands; they are very tough.

Avoid unintentional starts. Do not carry or handle tools with your hand on the operating switches or levers. Do not lay the tool down in a manner that will start the drive. Do not allow the tool to flip around or move when adjusting or changing tool bits.

Store idle tools properly. Disconnect tools from the power source and store in a safe place. Remove tool bits for safe handling of the tool.

GENERAL DESCRIPTION

The BOILERMASTER™ is a Pipe Beveler designed for facing, beveling and/or counterboring the ends of the pipe or tubing in preparation for welding.

These machining operations may be performed either simultaneously or separately.

Pipe weld end preparations that meet all existing conventional codes including the more stringent nuclear codes may be machined.

The various interchangeable Jaw Blocks and Ramps will secure the BOILERMASTER™ to pipe and tubing having an inside diameter ranging from 1.25" (31.8 mm) through 4.33" (110.0 mm).

The expanding mandrel provides fast, accurate self-centering and alignment to the pipe or tubing to be machined.

There are two (2) different head kits available. They are the 2.63" DIA head kit and the 4.00" DIA head kit.

The BOILERMASTER™ accepts the reaction torque generated by the machining operations through the mandrel.

No additional restraining devices are required.

SPECIFICATIONS

BOILERMASTER™ with an Air Motor

Weight	18 lbs (8.1 kg)
Power Requirements	67 cfm at 90 psi (32 L/s at 621 kPa)

PIPE CUTTING CAPACITIES

Basic Pipe Sizes

All schedules of 1 1/4" through 4" pipe.

Some schedules may require optional equipment.

Basic Tube Sizes

Up to .531" (13.5 mm) wall tubing with a maximum OD of 4.50" (114.3 mm) and minimum ID of 1.25" (31.7 mm) may be beveled with standard procedures.

Wall Thickness Capacity

Wall thickness of all standard pipe schedules (.531" [13.5 mm] maximum) in the range listed.

Contact TRI TOOL INC. for heavier wall procedures.

Counterboring Operations

The machine will counterbore pipe and tubing with an ID range of 1.50" (38.1 mm) to 4.33" (110.2 mm).

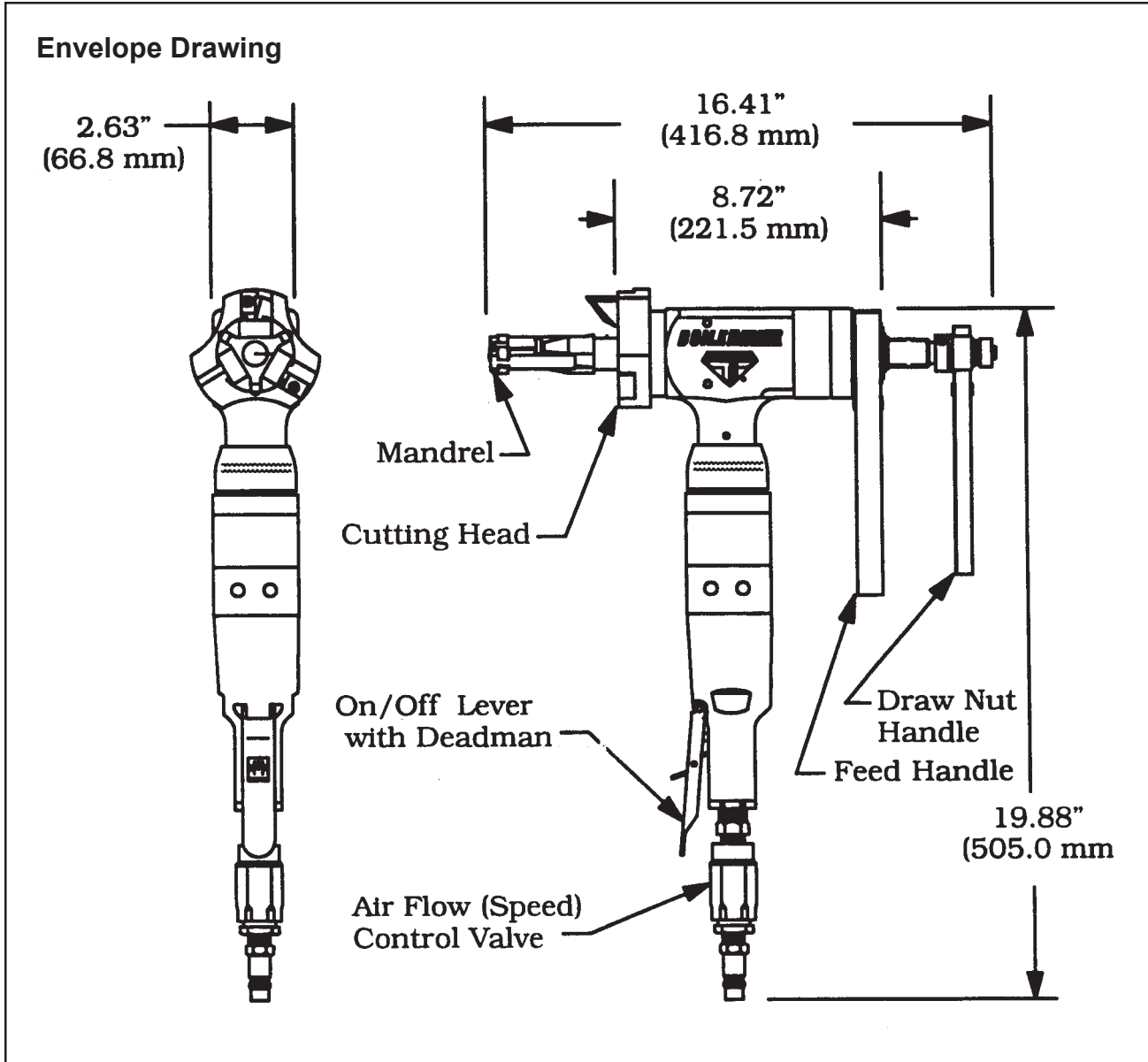

MATERIAL CUTTING CAPABILITIES

Mild steels, chrome steels (Rc 35 maximum), stainless steel, copper-nickel and aluminum without limitations except size and wall thickness as specified xxxxxx.

Inconel and some other high temperature alloys may require special procedures as a function of wall thickness and type of end preparation.

Contact the TRI TOOL INC. engineering department for details.

MODEL BOILERMASTER™ with an ELECTRIC MOTOR

Weight	18 lbs (8.1 kg)
Power Requirements	115 VAC, 28 to 60 Hz 5.25 amp

PIPE CUTTING CAPACITIES

Basic Pipe Sizes

1" Pipe

Schedule 40 (Small Mandrel required to mount in 1" schedule 80 and above.)

1 1/4" through 2 1/2" Pipe

Up to Schedule 80

3" through 4" Pipe

Up to Schedule 40

* Some Schedules may require optional equipment.

Basic Tube Sizes

Up to .250" (6.4 mm) wall tubing with a maximum OD of 4.50" (114.3 mm) and a minimum ID of 1.25" (31.7 mm) may be beveled with standard mandrel.

Wall Thickness Capacity (Limitations)

Wall thickness of schedules listed, .276" (7 mm) maximum, in the range listed can be machined without limitations.

Wall thicknesses greater than .276" (7 mm) require special procedures and are subject to Duty Cycle limitations to prevent motor damage. Contact Tri Tool Inc. for heavier wall procedures.

Counterboring Operations

The tool will counterbore pipe and tubing with an ID of 1.50" (38.1 mm) to 4.33" (110.2 mm).

DUTY CYCLE

The BOILERMASTER™ with an electric motor duty cycle on high cutting load applications (see above), is limited to 50% 'On' time with a maximum of five (5) minutes continuous 'On' time.

MATERIAL CUTTING CAPABILITIES

Mild steels, chrome steels, (Rc 35 max), stainless steel, copper-nickel alloys and aluminum without limitations except size and wall thickness as specified in the above paragraphs.

Inconel and some other high temperature alloys may require special procedures as a function of wall thickness and type of end preparations. Contact Tri Tool's Engineering Department for details.

DRIVE SYSTEM

Final Drive Gear Driven

Electric Motor - 2 speed Ranges & 6:1 Gear Reduction

Free speed

Low Range 168 rpm

High Range 316 rpm

Max. HP Speed

Low Range 112 rpm

High range 210 rpm

POWER SUPPLY

115 VAC, 5.25 Amps, 28 to 60 Hz.

CUTTING HEAD SPEEDS

Max. Cutting Head Speed

Low Range 84 rpm

High Range 156 rpm

Cutting Head Speed @ Max. H.P.

Low Range 56 rpm

High Range 105 rpm

Functional Speed Range 20 to 100 rpm

Speed Control

On/Off Trigger control with Variable Speed.

MOUNTING

Manually actuated draw rod expands mandrel ramps and jaw blocks.

FEED

Manual-Feed Handle is in line at the back of the machine. Feed rate is .100” (2.5mm) per revolution of the feed handle.

MAINTENANCE

All components should be cleaned and coated with a light film of oil prior to use.

Use a clean, non-detergent oil, preferably SAE 10 (90 SSU) or lighter or oil as specified for the air motor.

Air Supply for the BOILERMASTER™ with an air motor requires an adequate filter/regulator/lubricator (FRL) to be used.

A maximum of 90 PSI (621 kPa) line pressure is recommended.

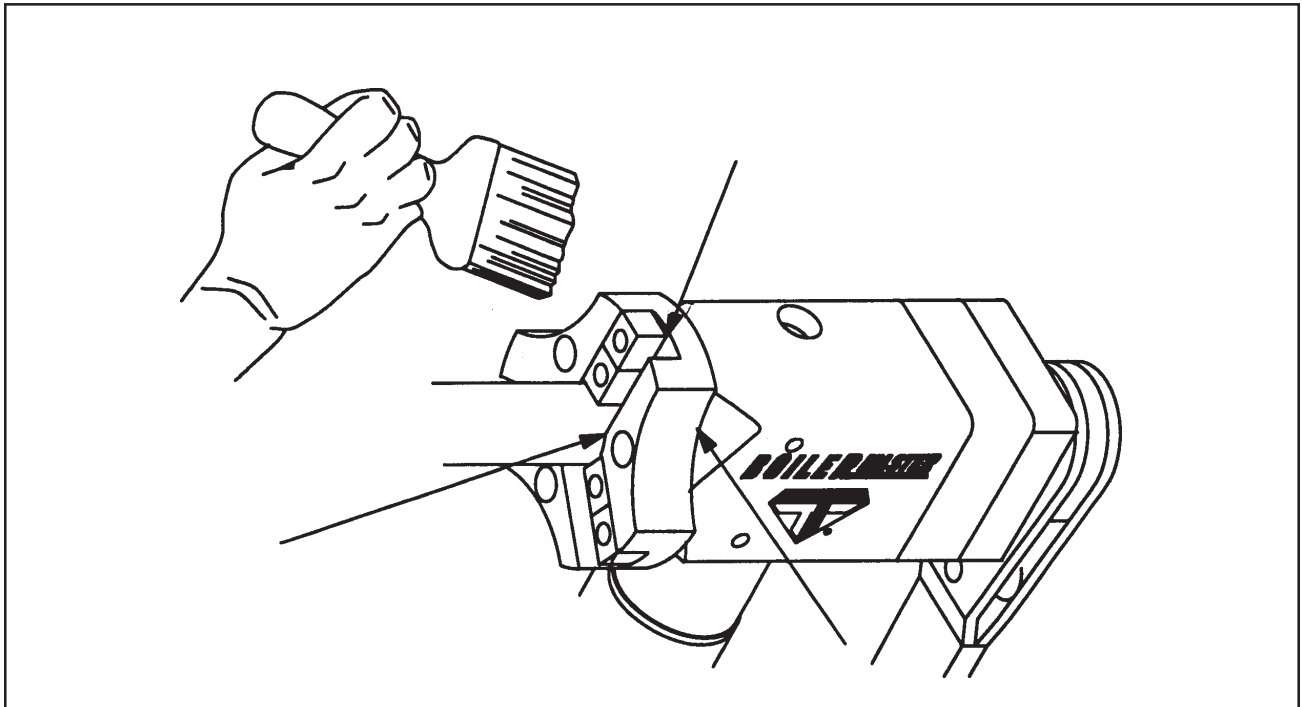

NOTE:

The Motor warranty is void if damage occurs from contaminated air or lack of lubrication.

If the BOILERMASTER™ is operated in the vertical position, cutting head up, it should be turned upside down and the chips and/or other debris removed after each bevel has been completed.

NOTE:

Tool life may be severely shortened, unless chips and/or other debris that have been deposited on the cutting head during the machining operations are removed.

Verify there's adequate grease in the gear box.

Gears and bearings are to be lubricated using a lithium based grease.

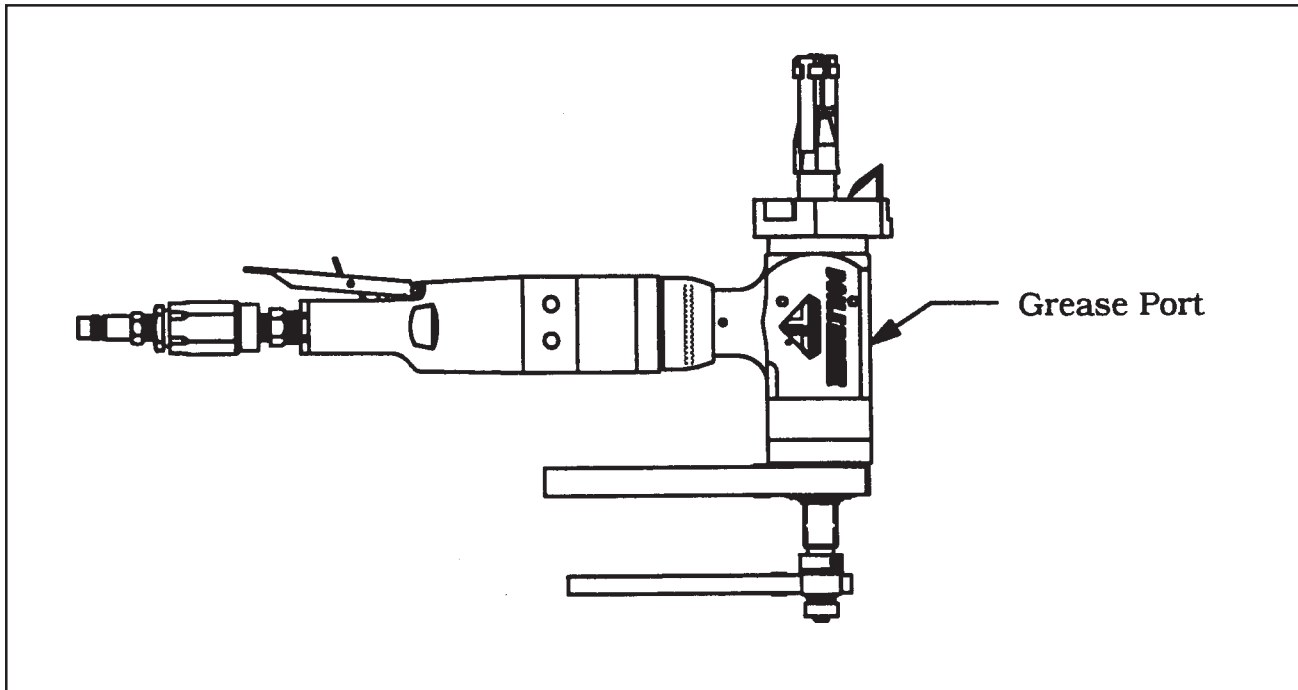

NOTE:

Disassembly of a power unit voids warranty, except when performed by a TRI TOOL Inc. designated repair technician. A letter of designation is required.

AIR MOTOR LUBRICATION

No direct maintenance is normally required on the air motor.

However, the air supply must flow through a filter/regulator/lubricator (FRL) unit or separate units before arriving at the air motor.

The FRL unit must be maintained as required, frequency dependent on the basic air supply, to keep the water trap drained, filter cleaned and the lubricator oil reservoir filled so that a drop of oil every 2 to 5 seconds is flowing.

If the BOILERMASTER™ is to be left idle for 24 hours or more after being run on 'wet' air, it is advisable to squirt oil directly into the air motor inlet and run the motor for 2 to 3 seconds.

This will prevent rusting and freezing of the rotor vanes.

LUBRICANT RECOMMENDATIONS

The air motor requires a Class 2 lubricant, viscosity of 100 to 200 SSU at 100° F (38° C) minimum aniline point of 200° F (93° C).

TRI TOOL Inc. – Air Tool Lubricant (P/N 68-0022)

- AMOCO – American Industrial Oil No. 32
- Atlantic Richfield – Duro Oil S-150
- Chevron – A. W. Machine Oil 32
- Exxon – Nuto H32
- Shell – Tellus Oil 32

The bearings in the air motor are sealed and do not require any lubrication.

The drive gears require a lithium-based grease.

OPERATION

Read the operating instructions carefully before attempting to operate the BOILERMASTER™

Use eye protection at all times when operating the BOILERMASTER™.

PREPARING THE BOILERMASTER™

Select the recommended jaw blocks for the pipe size to be machined.

Gently slide the mandrel assembly into the BOILERMASTER™ until it comes to a stop against the torque acceptance key.

Rotate the mandrel assembly as required to engage the torque acceptance key of the BOILERMASTER™ with the slot in the mandrel shaft.

NOTE:

Since the mandrel shaft will contact the torque acceptance key before the feed nut engages the mandrel shaft threads, caution should be taken not to force (or allow) the machine to impact the lead threads of the feed nut with the lead threads of the mandrel.

Rotate the feed handle clockwise to engage the feed nut with the thread on the mandrel shaft.

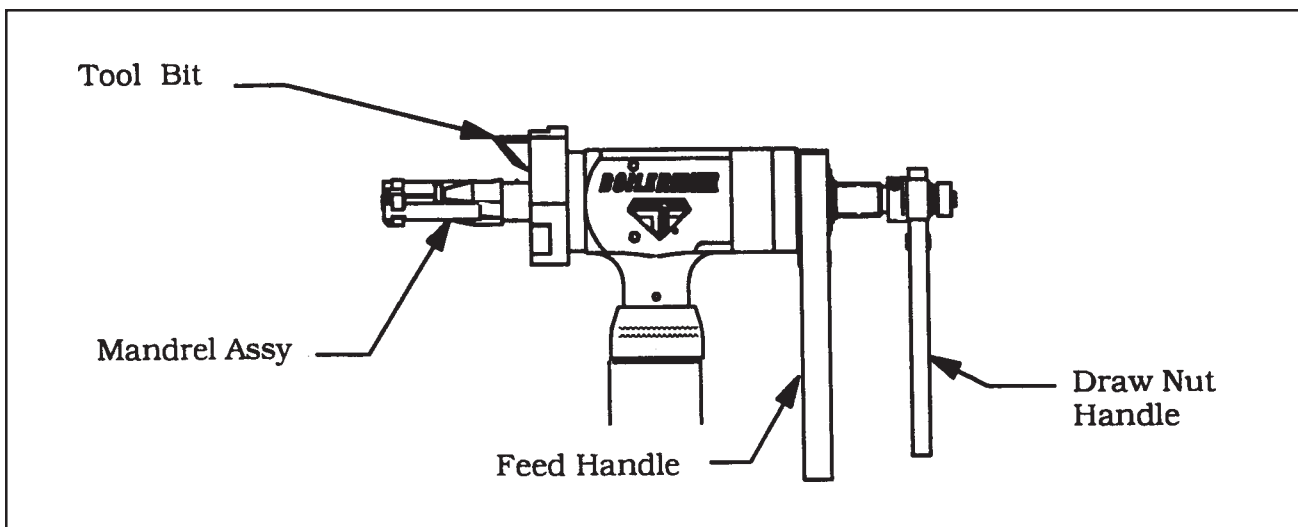

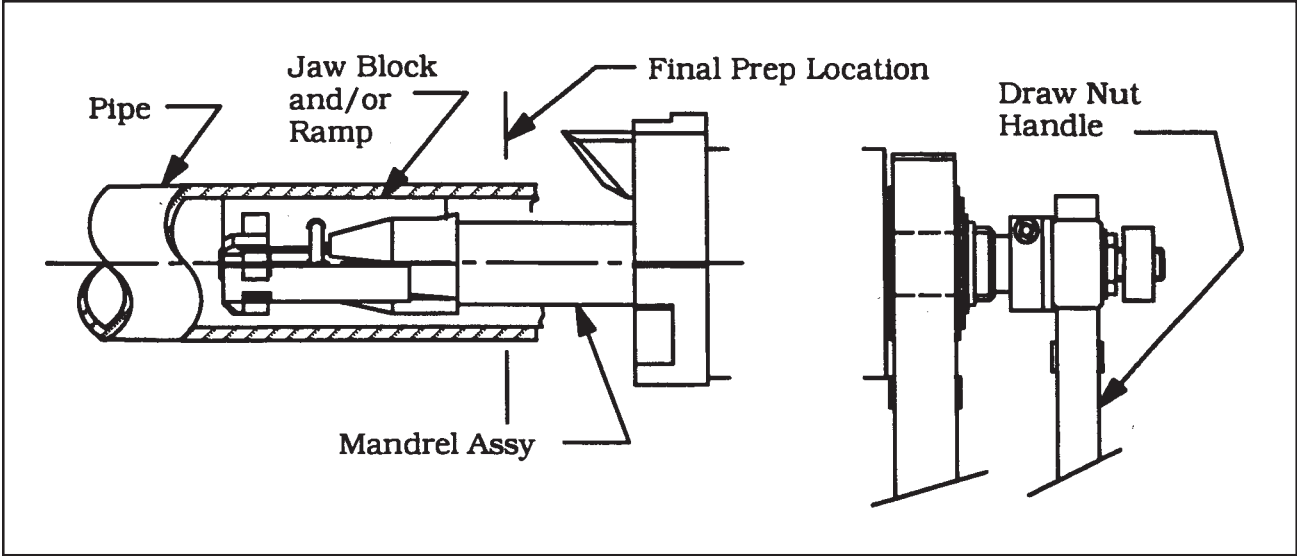

The BOILERMASTER™ with the mandrel assembly installed may be mounted into the pipe or tube as one unit.

NOTE: In order to avoid cutting the ramps and/or jaw blocks during the machining operation, the mandrel must be installed beyond the final end preparation location.

Tighten the draw nut to force the jaw blocks out to the inside diameter of the pipe or tube.

TOOL BIT INSTALLATION

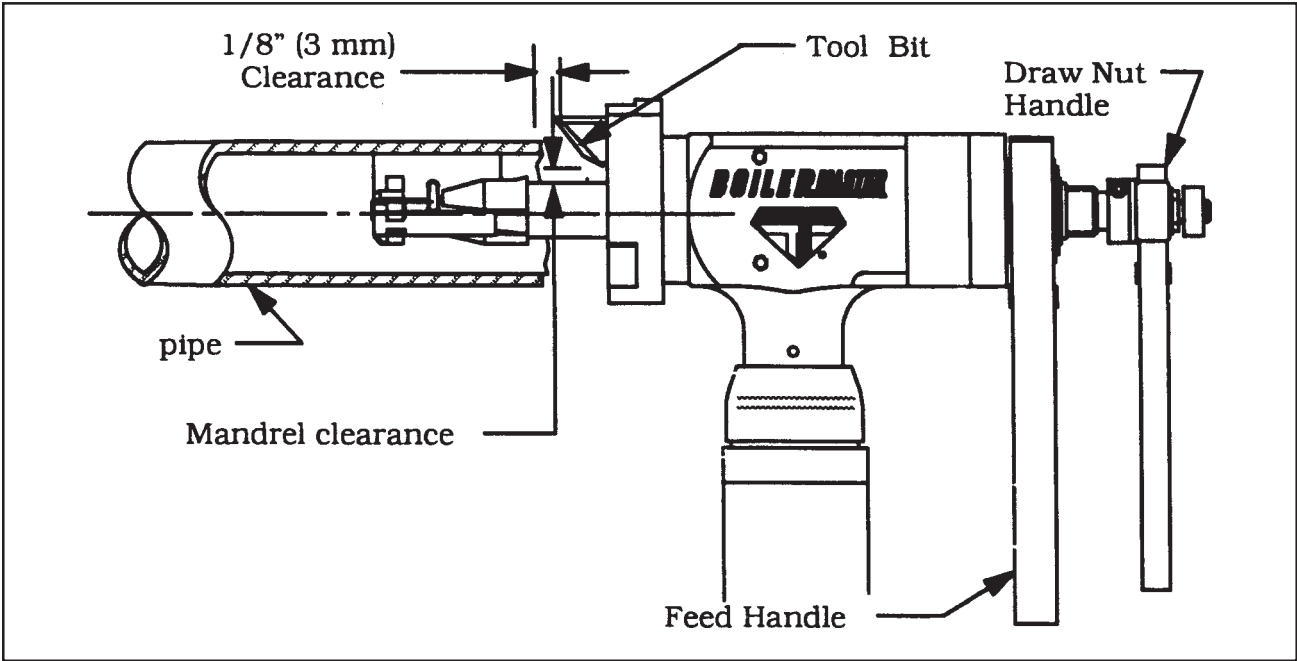

TRI TOOL INC.

Verify a clearance of 1/8" (3 mm) minimum between the tool bit and the pipe face.

Select the tool bit(s) required to machine the pipe to the configuration desired.

WARNING: Use of dull or improperly designed tool bits or tool bits not manufactured by TRI TOOL INC. may result in poor performance and may constitute abuse of this machine and therefore voids the TRI TOOL INC. factory warranty.

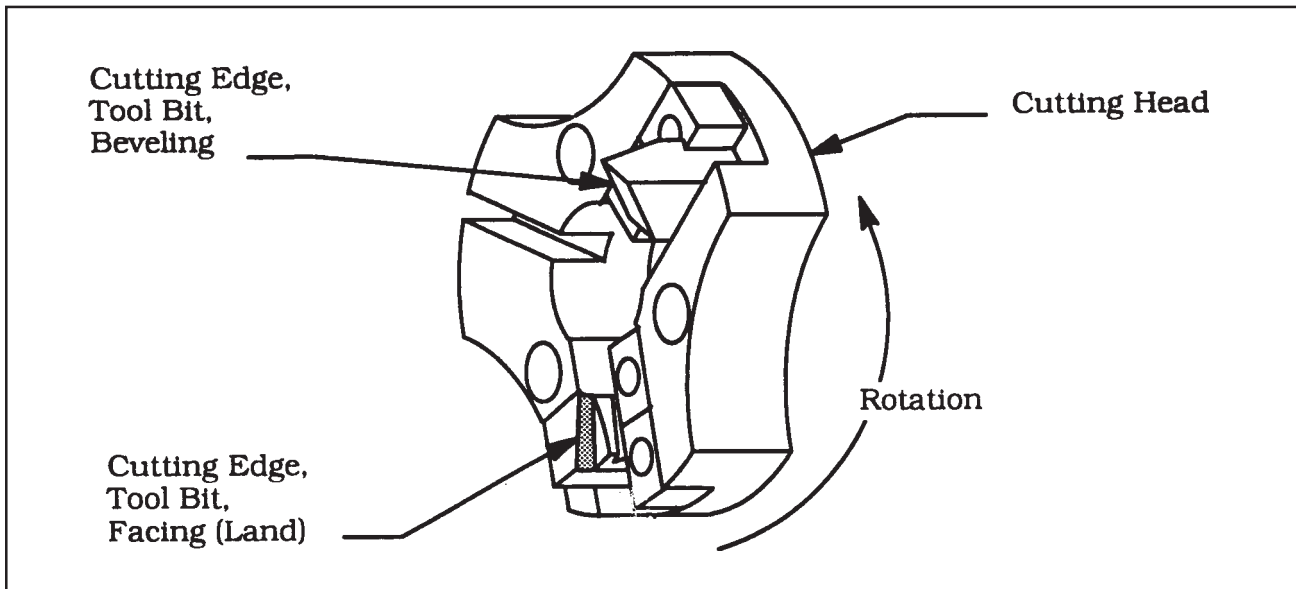

When performing any multiple machining operation such as facing and beveling, the facing tool bit should be installed as shown above.

Insert the tool bit(s) into the slot(s) in the cutting head.

CAUTION: The cutting edge of the tool bit(s) must be located on the radial centerline.

CAUTION: Insure that no tool bit is installed backwards.

Make sure that there is a clearance between the tool bit(s) and the mandrel.

Tighten the wedge screws or set screws to secure the tool bit in the slot.

Adjust the bevel tool bit radially to control the land width.

OPERATION

Attach the proper air supply line to the BOILERMASTER™

NOTE: Check that the filter/regulator/lubricator (FRL) is installed and set properly.

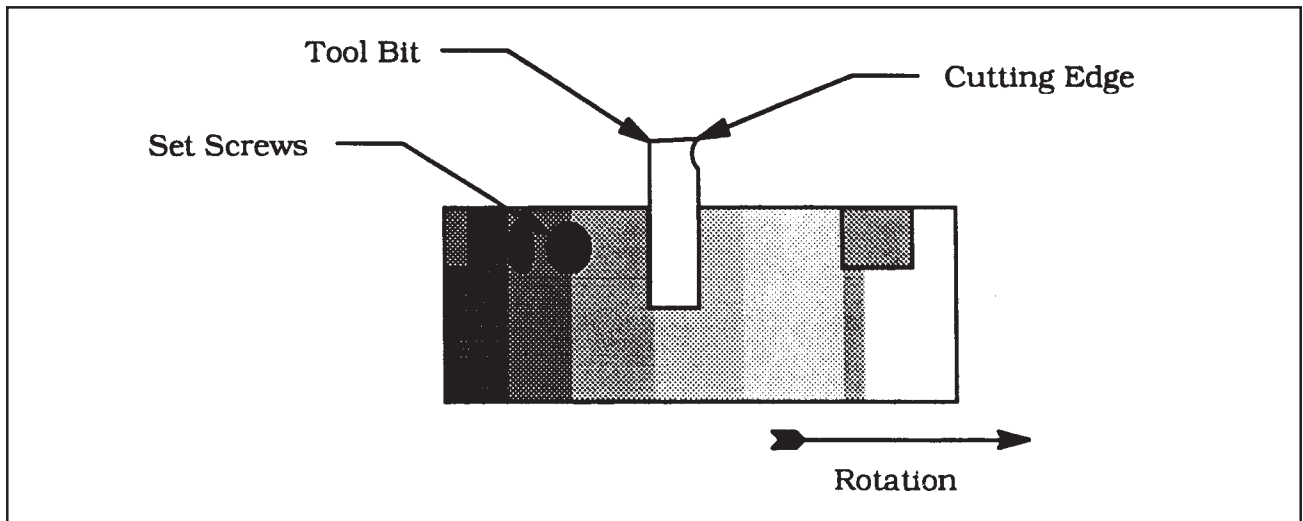
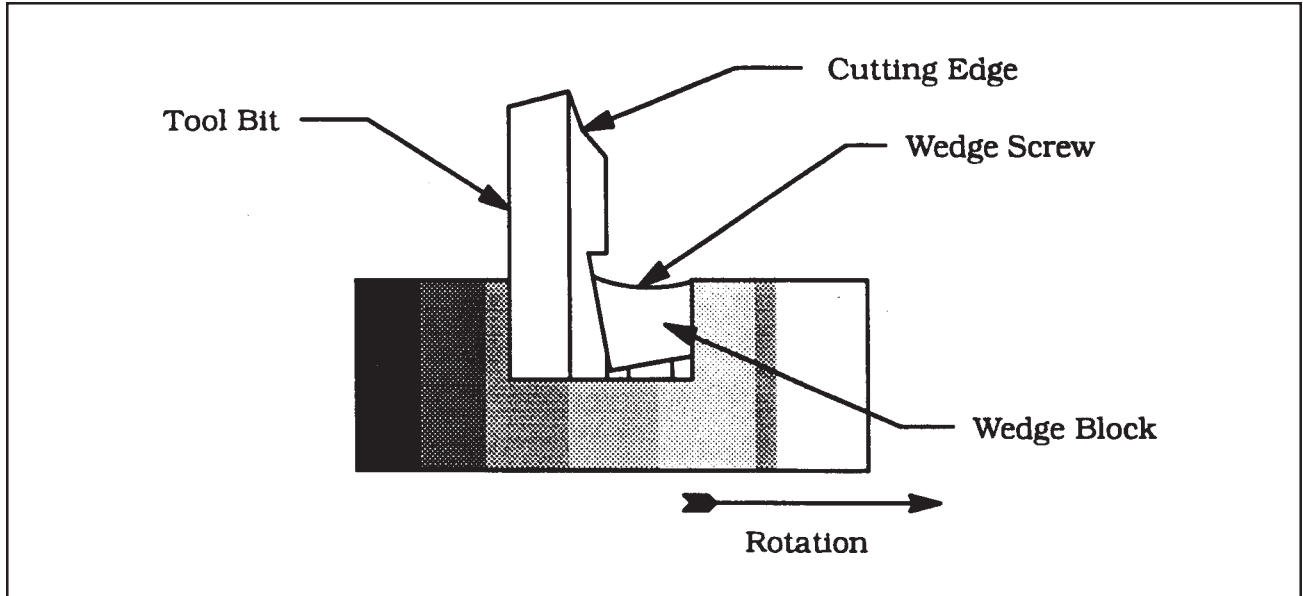

Depress the air motor trigger. Adjust the cutting speed by rotating the flow valve at the air connection. Reference the 'Cutting Speeds and Feeds' later in this manual.

Rotate the feed handle clockwise to bring the tool bit(s) and pipe closer together.

CAUTION: The actual machining operation will begin when the first tool bit contacts the pipe.

WARNING: DO NOT OVERRIDE THE DEADMAN SWITCH ON THIS UNIT. Locking down, obstructing, or in any way defeating the deadman switch on this unit may result in serious injury.

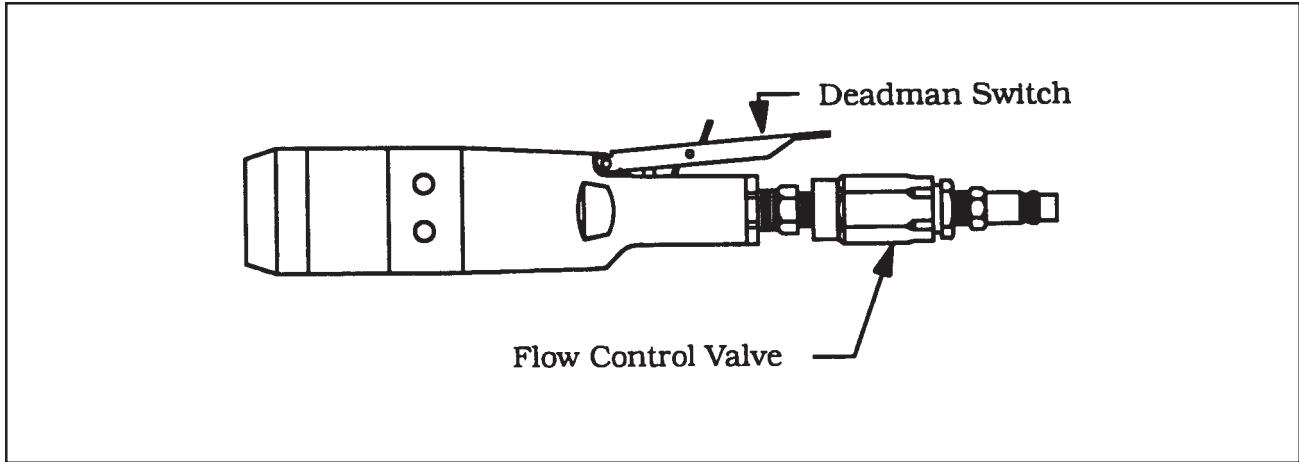

If the pipe end is not square to the pipe axis, the tool bit will contact only a small segment of the pipe during each revolution.

To avoid tool bit damage, the feed rate should be very slow until the tool bit(s) is in contact with the pipe continually during at least one full revolution.

Continue rotating the feed handle clockwise until the end of the pipe is completely machined.

Discontinue feed and allow the head to rotate 1 to 3 revolutions to improve finish of the prep surface.

Release the air motor trigger to stop the head rotation.

Rotate the feed handle counterclockwise to separate the tool bit(s) from the pipe.

Rotate the feed handle counterclockwise until the tool bit to pipe clearance is 1/8" (3 mm).

Loosen the draw nut on the mandrel to release the mandrel from the pipe.

The mandrel assembly may be left in the BOILERMASTER™ and installed as a complete assembly.

CUTTING SPEEDS AND FEEDS

Nominal Pipe Diameter	True DIA		RPM for	RPM for	RPM for
			200 in / min (5080 mm / min)	250 in / min (6350 mm / min)	300 in / min (7620 mm / min)
1"	1.315"	33.4 mm	48	61	73
2"	2.375"	60.3 mm	27	34	40
3"	3.500"	88.9 mm	18	23	27
3 1/2"	4.000"	101.6 mm	16	20	24
4"	4.500"	114.3 mm	14	18	21
Cutting Speed (approximately)					

Use 200 surface inches per minute (5080 surface millimeters per minute) for:

Stainless steels in general when no coolant is allowed, all heavy-wall tube and some chrome/molybdenum steels.

Use 250 surface inches per minute (6350 surface millimeters per minute) for:

Mild steels and some thin-wall stainless steels when coolants are permitted and applied.

Use 300 surface inches per minute (7620 surface millimeters per minute) for:

Aluminum and some thin-wall mild steel and tube with coolants.

CUTTING FEEDS

Use very light feed for initial beveling or until a continuous cut is established.

This is very important for longer tool bit life when cutting through flame cut or out of square pipe ends.

Use adequate feed, .003" to .006" (.08 mm to .15 mm) per revolution there-after, to establish a continuous chip cut.

If the feed is too light, only light stringer chips will be removed.

If the feed is too heavy the drive will start to overload and the chip will start to have a rough or torn appearance.

Stainless steel which work hardens, must be worked with a haevy enough feed to stay under the work hardened surface, .003 (.08 mm) to .006" (.15 mm) feed.

Never allow the Tool Bit to burnish the surface.

Reduced feeds and speeds will normally minimize chatter problems.

JAW BLOCKS AND RAMP SETS

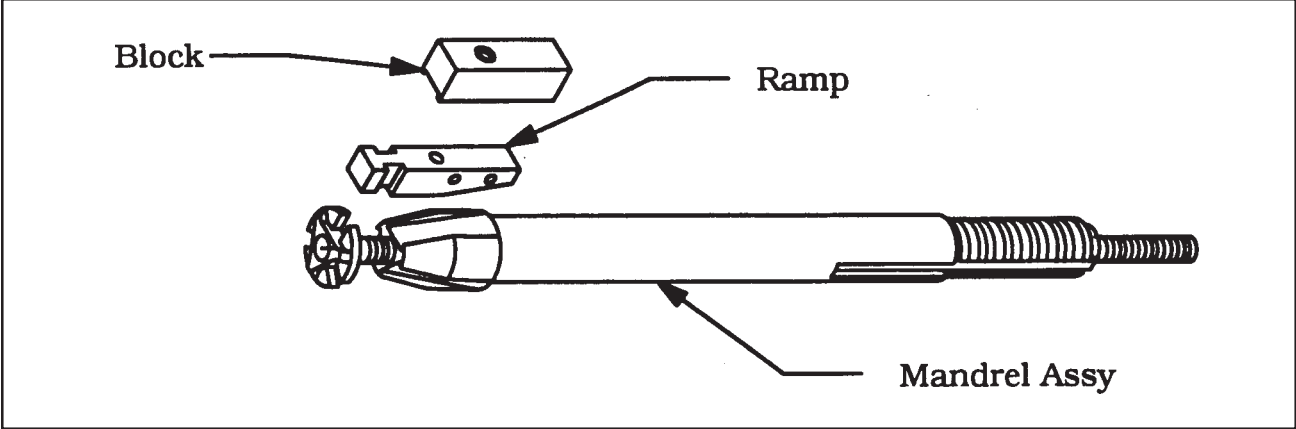

ID Mounting Range	Standard Ramp (3 Req'd)	Jaw Block Assembly (3 Req'd)	Block Height
1.250" to 1.630" (31.8 mm to 41.4 mm)	48-0964		
1.560" to 2.000" (39.6 mm to 50.8 mm)	48-0965		
1.930" to 2.390" (49.0 mm to 60.7 mm)	48-0966		
2.320" to 2.780" (58.9 mm to 70.6 mm)	48-0965	08-0376	.442" (11.2 mm)
2.710" to 3.160" (68.8 mm to 80.3 mm)	48-0965	08-0377	.645" (16.4 mm)
3.090" to 3.550" (78.5 mm to 90.2 mm)	48-0965	08-0378	.841" (21.4 mm)
3.480" to 3.940" (88.4 mm to 100.1 mm)	48-0965	08-0379	1.041" (26.4 mm)
3.870" to 4.330" (98.3 mm to 110.0 mm)	48-0965	08-0380	1.239" (31.5 mm)
NOTE: Blocks can only be mounted on the #2 Ramp (P/N 48-0965) Steel Jaw Blocks and Ramps for Mandrel Assembly (P/N 06-0415)			

Mounting ID	Ramp and Block Combination	
1.250" to 1.630" (31.8 mm to 41.4 mm)		
1.560" to 2.000" (39.6 mm to 50.8 mm)		
1.930" to 2.390" (49.0 mm to 60.7 mm)		
2.320" to 2.780" (58.9 mm to 70.6 mm)		<p>08-0376 .442" (11.2 mm) 48-0965</p>
2.710" to 3.160" (68.8 mm to 80.3 mm)		<p>08-0377 .645" (16.4 mm) 48-0965</p>

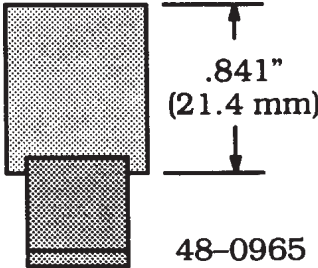
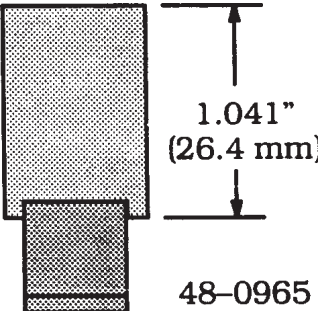
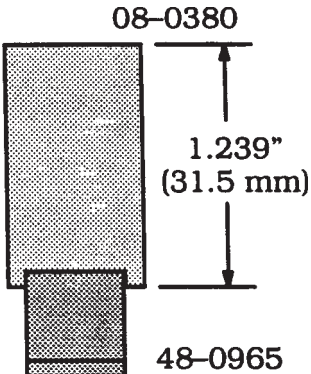
Mounting ID	Ramp and Block Combination
3.090" to 3.550" (78.5 mm to 90.2 mm)	 <p>08-0378 .841" (21.4 mm) 48-0965</p>
3.480" to 3.940" (88.4 mm to 100.1 mm)	 <p>08-0379 1.041" (26.4 mm) 48-0965</p>
3.870" to 4.330" (98.3 mm to 110.0 mm)	 <p>08-0380 1.239" (31.5 mm) 48-0965</p>

Steel Jaw Blocks and Ramp profiles for the Standard Mandrel.

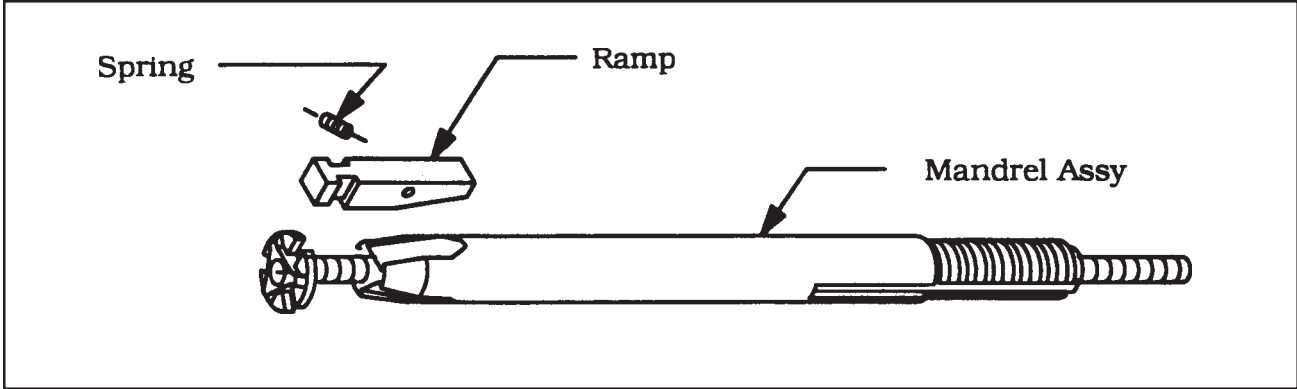

ID Mounting Range	Butt Plate P/N	Spring P/N	Ramp P/N
1.000" to 1.250" (25.4 mm to 31.8 mm)	24-1462	40-0108	48-0976
Butt Plate, Spring and Ramp for Mandrel Assembly (P/N 06-0414)			

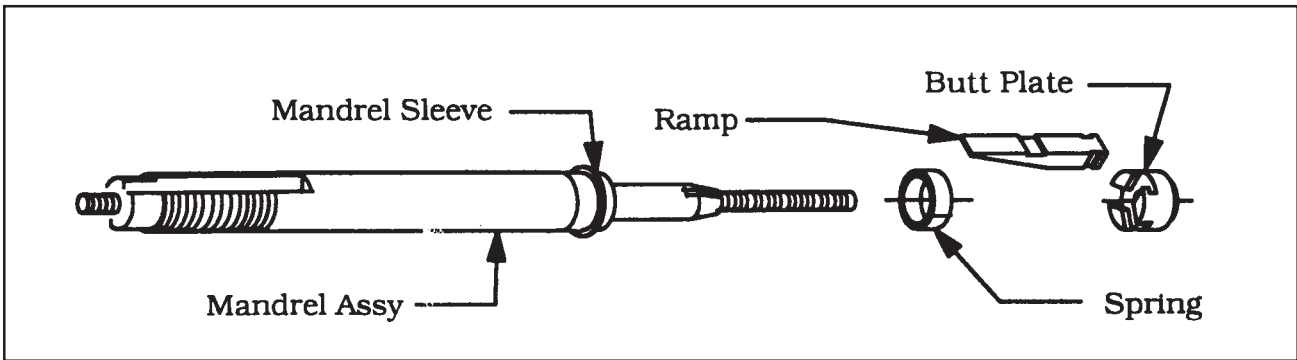

ID Mounting Range	Butt Plate P/N	Spring P/N	Ramp P/N
.610" to .800" (15.5 mm to 20.3 mm)	24-1463	40-0130	48-0596
.800" to 1.000" (20.3 mm to 25.4 mm)	24-1464	40-0136	48-0597
Butt Plate, Spring and Ramp for Mandrel Assembly (P/N 06-0413)			

TOOL BITS

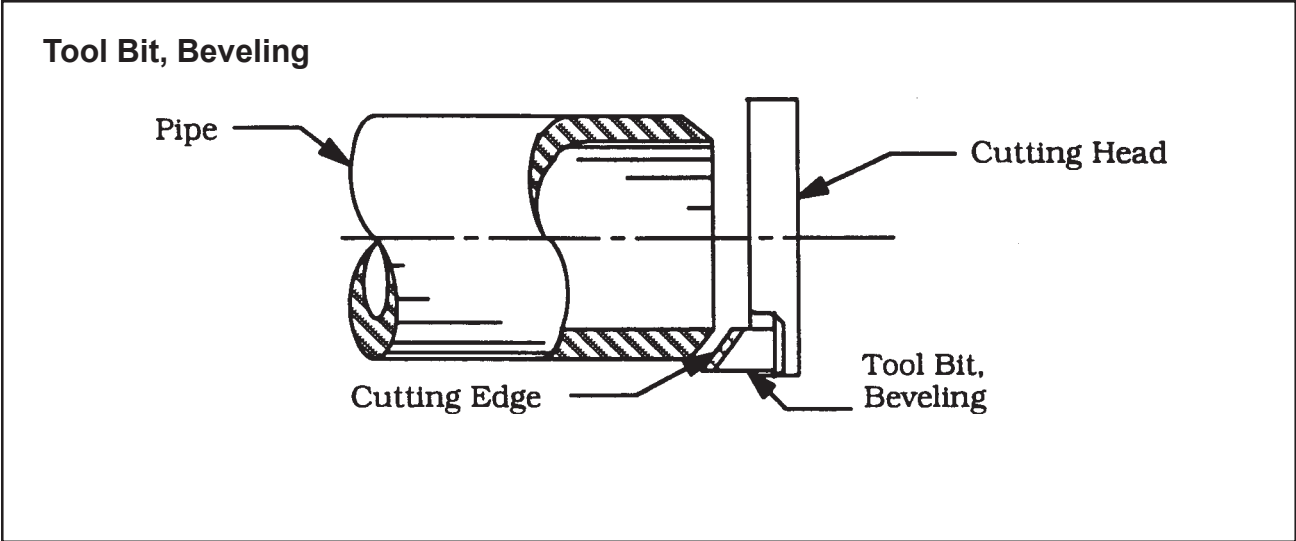

2.63" DIA Head Kit

ID Mounting Range	Pipe or Tube Material	Max Wall Thickness	Beveling 37.5 Degree Tool Bit P/N
1.25" ID thru 2.63" OD (31.8 mm ID thru 66.8 mm OD)	CS/SS	.531" (13.5 mm)	BOILERMASTER™

4.00" DIA Head Kit

ID Mounting Range	Pipe or Tube Material	Max Wall Thickness	Beveling 37.5 Degree Tool Bit P/N
1.25" ID thru 4.50" OD (31.8 mm ID thru 114.3 mm OD)	CS/SS	.531" (13.5 mm)	BOILERMASTER™

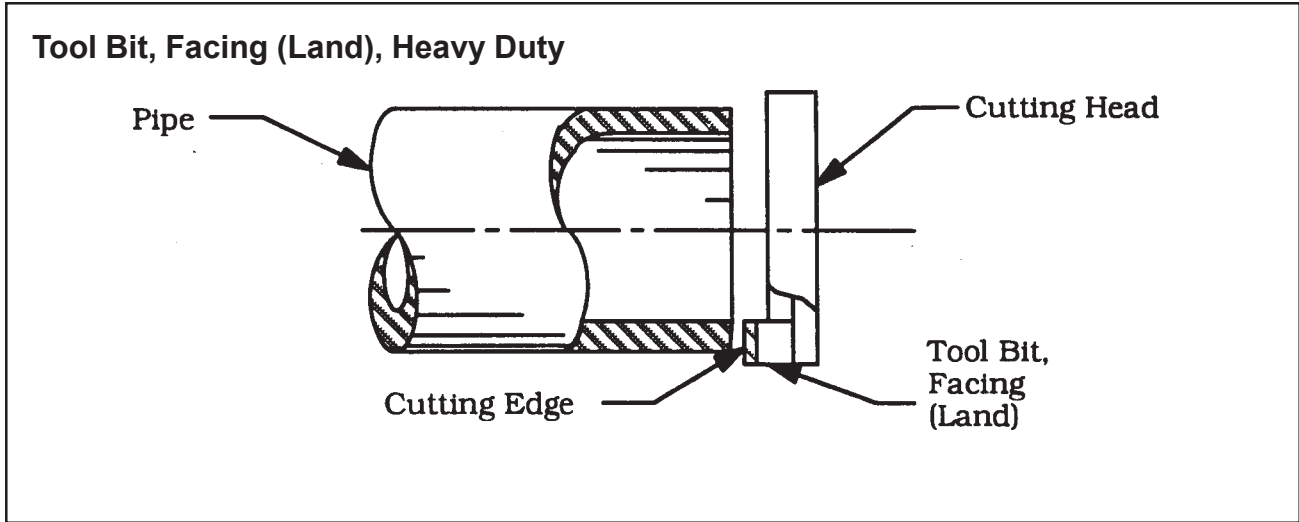

2.63" DIA Head Kit

ID Mounting Range	Pipe or Tube Material	Max Wall Thickness	Facing Tool Bit P/N
1.25" ID thru 2.63" OD (31.8 mm ID thru 66.8 mm OD)	CS/SS	.531" (13.5 mm)	99-5243

4.00" DIA Head Kit

ID Mounting Range	Pipe or Tube Material	Max Wall Thickness	Facing Tool Bit P/N
1.25" ID thru 4.50" OD (31.8 mm ID thru 114.3 mm OD)	CS/SS	.531" (13.5 mm)	99-5243

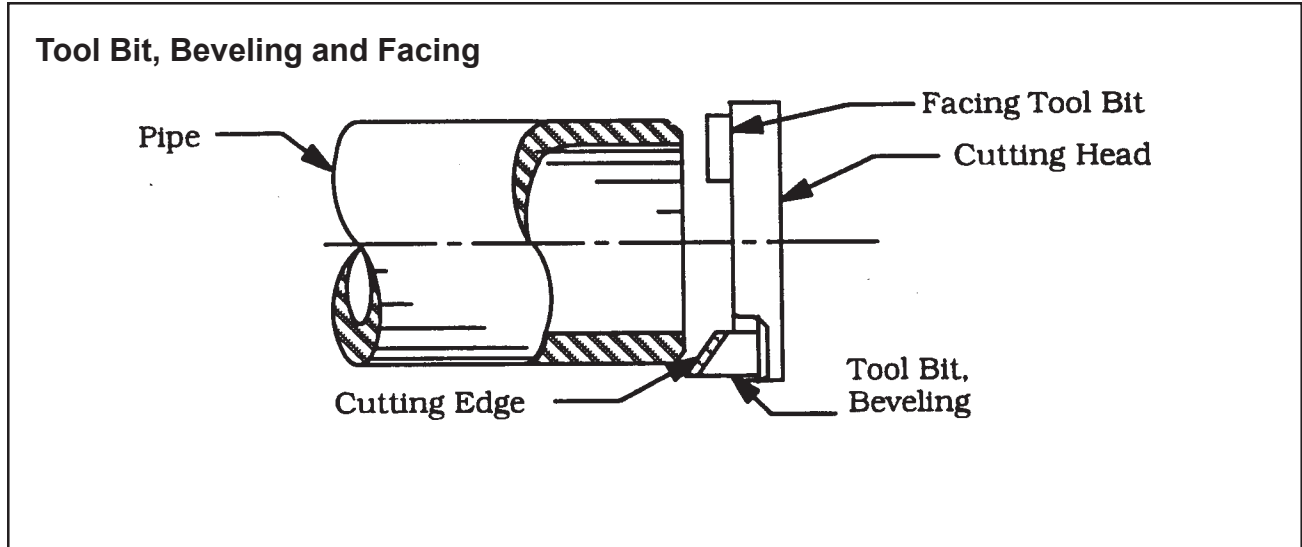

2.63" DIA Head Kit

ID Mounting Range	Pipe or Tube Material	Max Wall Thickness	Beveling 37.5 Degree Tool Bit P/N	Facing Tool Bit P/N
1.25" ID thru 1.90" ID (31.8 mm ID thru 48.3 mm ID)	CS/SS	.531" (13.5 mm)	BOILERMASTER™	99-0257
1.83" ID thru 2.57" ID (46.5 mm ID thru 65.3 mm ID)	CS/SS	.531" (13.5 mm)	BOILERMASTER™	99-2095

4.00" DIA Head Kit

ID Mounting Range	Pipe or Tube Material	Max Wall Thickness	Beveling 37.5 Degree Tool Bit P/N	Facing Tool Bit P/N
1.25" ID thru 3.27" ID (31.8 mm ID thru 83.1 mm ID)	CS/SS	.531" (13.5 mm)	BOILERMASTER™	99-0257
1.83" ID thru 3.92" ID (46.5 mm ID thru 99.6 mm ID)	CS/SS	.531" (13.5 mm)	BOILERMASTER™	99-2095

TROUBLE SHOOTING

Problem: The Tool Bit Chatters

The tool bit is loose or over extended.
The tool bit is damaged.
The tool holder is too loose in the slides.
The cutting speed is too fast.
The clamping pads are loose on the pipe or tube.
Cutting fluid is required.
The main bearing pre-load is loose.

Problem: There is excessive Tool Bit wear

The pipe or tube material is too hard or abrasive.
The cutting speed is too fast.
Cutting fluid is required.
A dull Tool Bit is causing surface hardening conditions (Stainless pipe or tubing).
There is scale or other foreign matter on the pipe or tube, which is dulling the tool bit at the start of the cut.
The tool bit is incorrect for the material being cut.

Problem: The surface finish is rough

The tool bit is dull, chipped, etc.
Metal buildup on the cutting edge of the tool bit is creating a false cutting edge.
Cutting fluid is required.

Problem: The tool holder is not feeding

The feed pin is broken or out of position.
The feed sprocket shear pin is broken.
The feed screw is stripped.
The feed nut is stripped.
The slide rails are too tight.

Problem: There is a loss of air power

The air supply pressure is too low.
The air filter is plugged.
The air line size is insufficient.
The air line is too long.

Problem: There is a loss of hydraulic power

The hydraulic supply pressure is too low.
The hydraulic filter is plugged.
The hydraulic line size is insufficient.
The hydraulic line is too long.

Problem: The tool bit will not reach the work

Incorrect tool blocks are installed for the size of the pipe or tube being worked on.
Incorrect tool bit is installed.

Problem: The hydraulic motor will not start

The hydraulic power supply is shut off.
The hydraulic motor is damaged and will not run free.

ACCESSORIES

The following accessories are recommended for use with the BOILERMASTER™ and are available from TRI TOOL INC.

1. Portable Air Filter (P/N 75-0115)

A portable Air Caddy (FRL) is required to protect the warranty on all TRI TOOL INC air driven tools.

ILLUSTRATED PARTS BREAKDOWN

BOILERMASTER™ SUB-ASSEMBLY (P/N 02-2215)

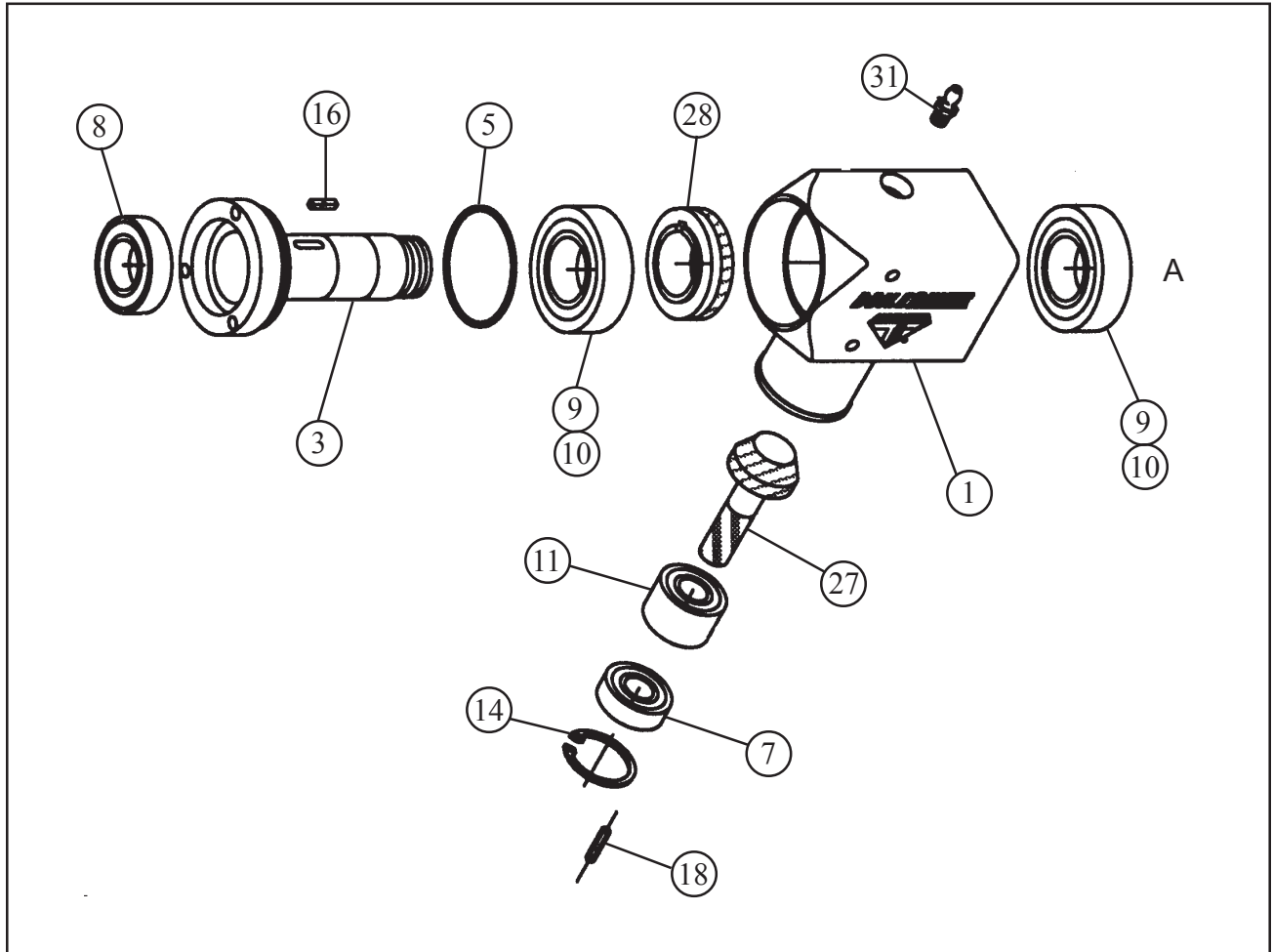

Parts List, BOILERMASTER™ Sub-Assembly (P/N 02-2215)

Item No.	Part No.	Description	Qty
1.	19-0728	HOUSING, MAIN	1
2.	19-0729	HOUSING, FEED	1
3.	20-1025	SHAFT, MAIN	1
4.	27-0513	ADAPTER, FEED	1
5.	28-0248	O-RING	1
6.	29-0005	BEARING, BALL	1

BOILERMASTER™ SUB-ASSEMBLY (P/N 02-2215)

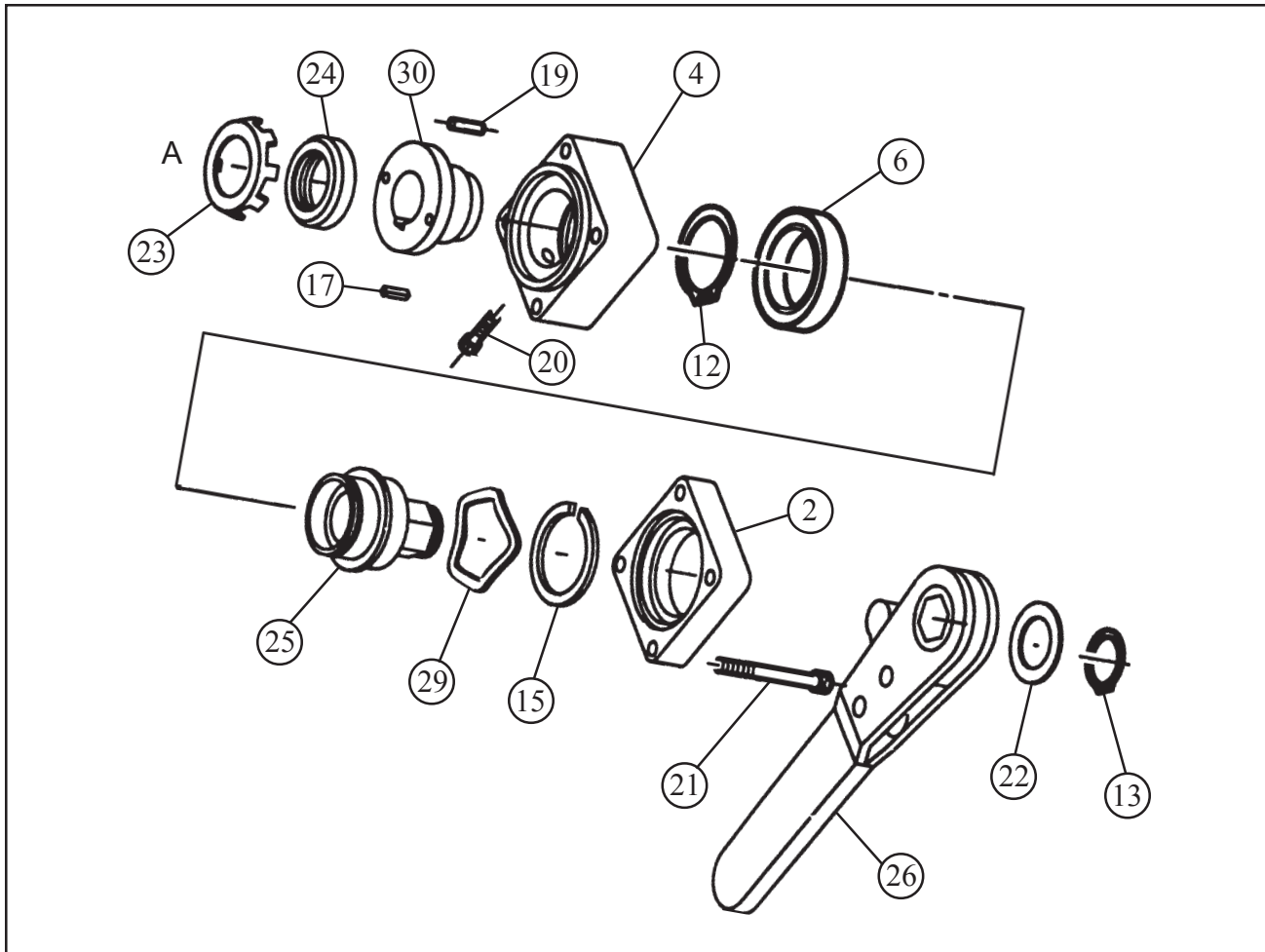

Parts List, BOILERMASTER™ Sub-Assembly (P/N 02-2215) Continued

Item No.	Part No.	Description	Qty
7.	29-0326	BEARING, BALL	1
8.	29-0327	BEARING, BALL	1
9.	29-0328	BEARING, TAPER, CONE	2
10.	29-0329	BEARING, TAPER, CUP	2
11.	29-0345	BEARING, BALL	1
12.	30-0309	RING, RETAINING, EXTERNAL	1
13.	30-0411	RING, RETAINING, EXTERNAL	1
14.	30-2358	RING, RETAINING, INTERNAL	1
15.	30-2359	SHIM	1
16.	31-0103	KEY, SQUARE, ROUND ENDS	1

Parts List, BOILERMASTER™ Sub-Assembly (P/N 02-2215) Continued

Item No.	Part No.	Description	Qty
17.	31-0155	KEY, SQUARE, ROUND ENDS	1
18.	32-0493	PIN, DOWEL, 1/8" DIA X .88"	1
19.	32-0081	PIN, DOWEL, 3/16" DIA X .75"	2
20.	33-0030	SCREW, CAP, #10-24 X .75"	1
21.	33-0047	SCREW, CAP, 1/4-20 X 2.25"	4
22.	34-0236	WASHER, THRUST	1
23.	34-0310	WASHER, LOCK	1
24.	35-0443	NUT, LOCK	1
25.	35-0444	NUT, FEED	1
26.	36-0213	WRENCH, RATCHET	1
27.	39-0754	GEAR, BEVEL, PINION	1
28.	39-0755	GEAR, BEVEL	1
29.	40-0227	SPRING, WAVE	1
30.	45-0248	BUSHING, FEED ADAPTER	1
31.	54-0375	FITTING, GREASE	1
NOT SHOWN			
	36-0004	WRENCH, L, 7/64" HEX	1
	36-0006	WRENCH, L, 9/64" HEX	1
	36-0007	WRENCH, L, 5/32" HEX	1
	36-0010	WRENCH, L, 1/4" HEX	1
	36-0018	WRENCH, T, 1/8" HEX	1
	36-0020	WRENCH, T, 5/32" HEX	1
	36-0216	WRENCH, L, 5/32" HEX	1
	86-0209	CARRYING CASE	1

MOTOR ASSEMBLY, AIR (P/N 57-0224)

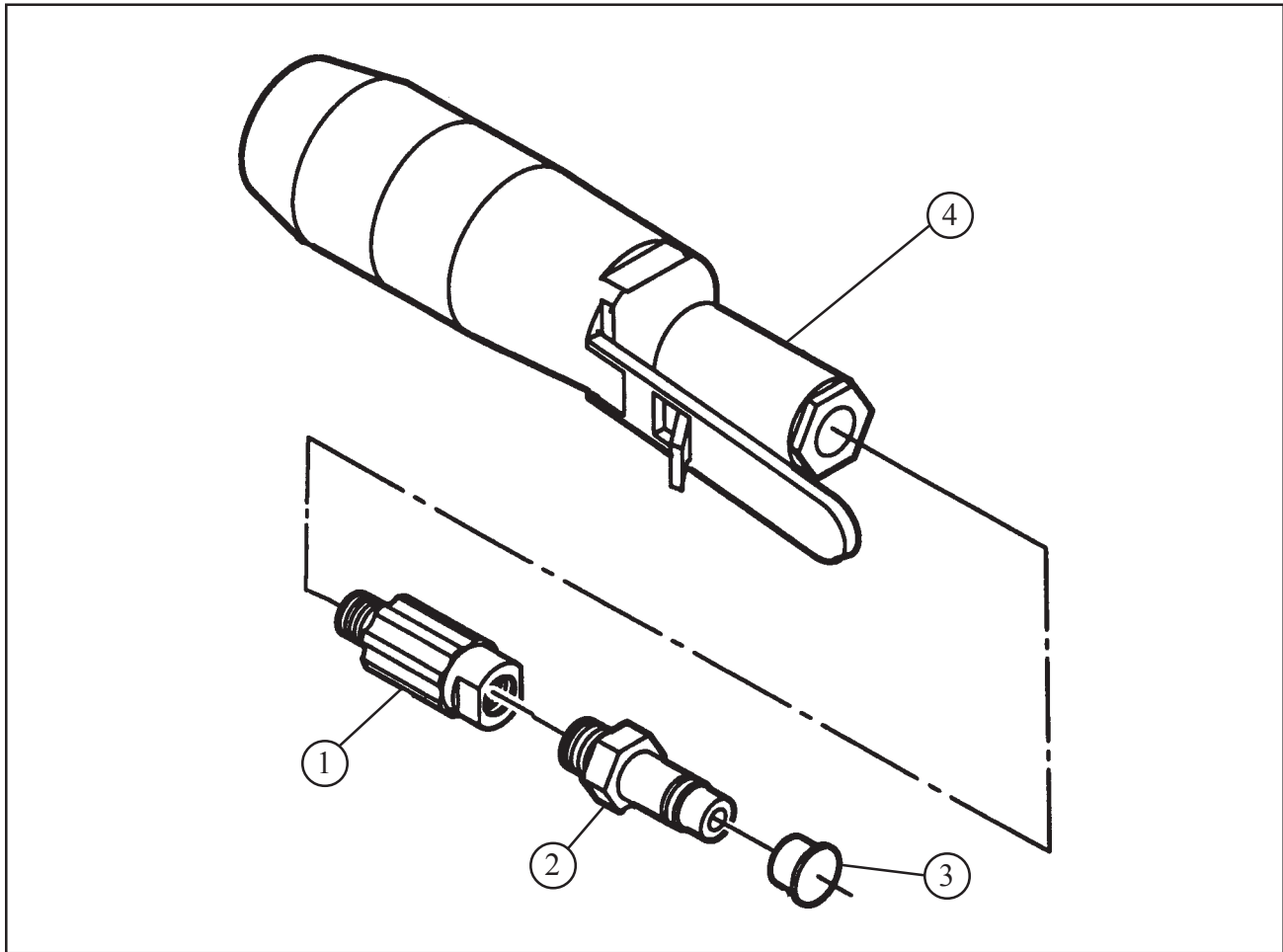

Parts List, Motor Assembly, Air (P/N 57-0224)

Item No.	Part No.	Description	Qty
1.	53-0046	VALVE, FLOW CONTROL	1
2.	54-0126	COUPLING, MALE QD	1
3.	54-0201	CAP, YELLOW	1
4.	57-0223	MOTOR, INLINE AIR	1

ELECTRIC MOTOR ASSEMBLY, 220V

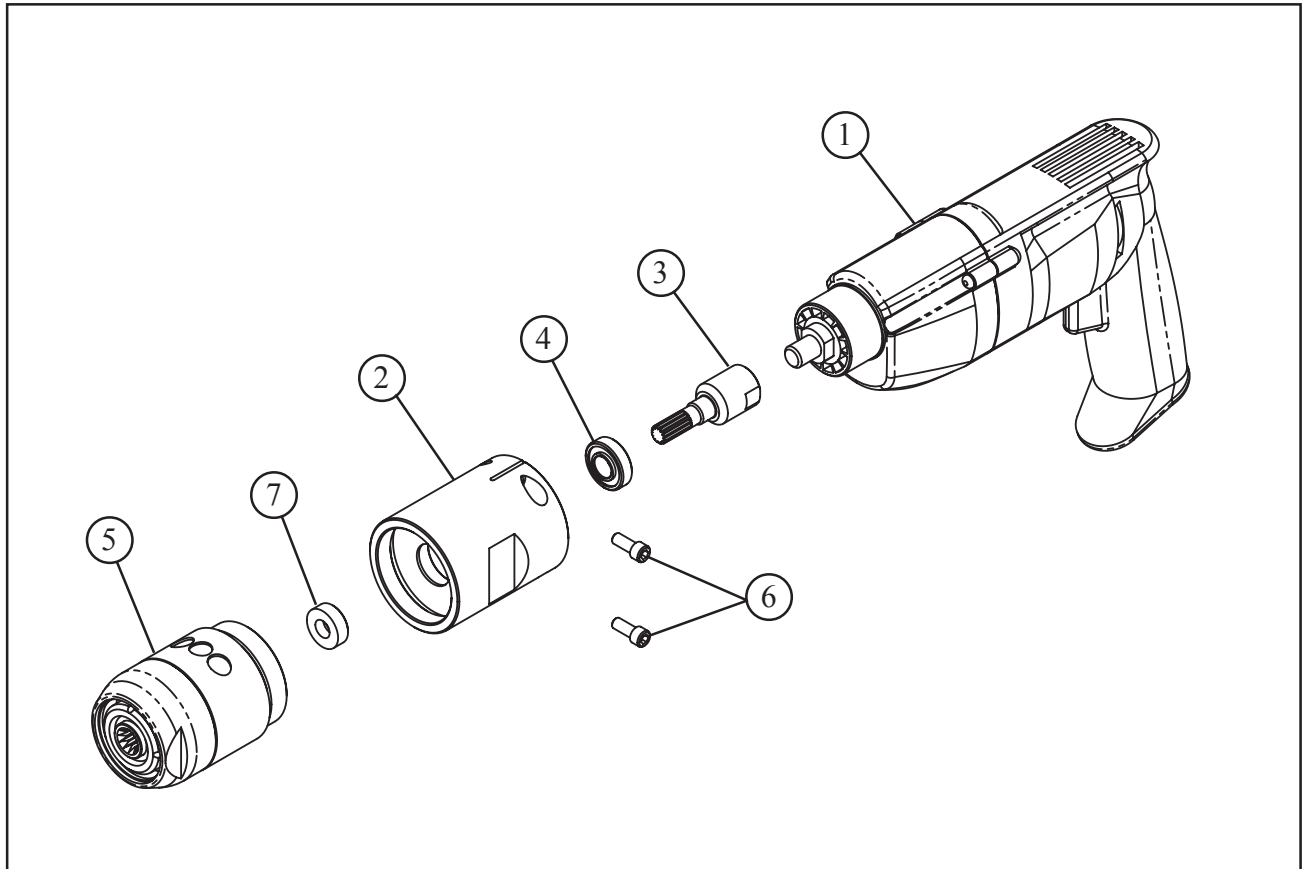

Parts List, Electric Motor Assembly, 220V

Item No.	Part No.	Description	Qty
	58-0133	MOTOR ASSEMBLY, 220V	1
1.	58-0039	MOTOR, MOD, ELECTRIC, 220V	1
2.	27-0357	ADAPTER, MOTOR	1
3.	39-0568	GEAR, DRIVE	1
4.	29-0182	BEARING, BALL, 1/2" X 1 1/8" X 3/8"	1
5.	91-0545	GEAR ASSEMBLY	1
6.	33-0039	SCREW, CAP, 1/4-20 X 5/8"	2
7.	44-0441	SPACER	1

CUTTING HEAD KIT, 2.63" DIA (P/N 03-0047)

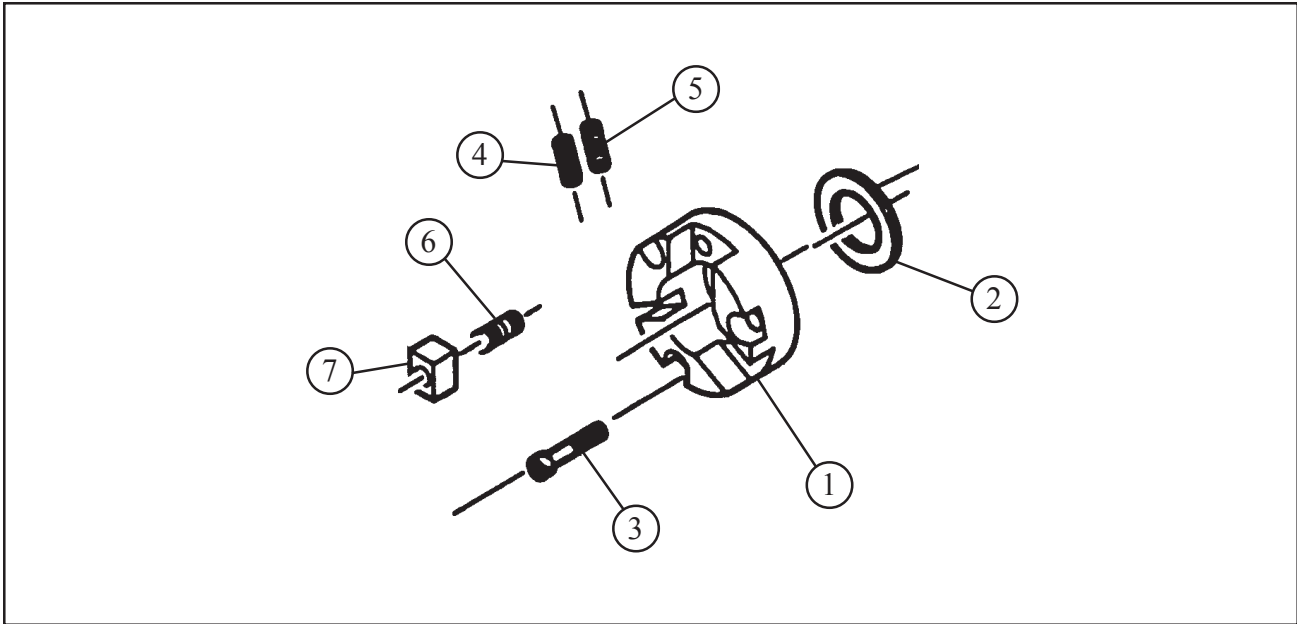

Parts List, Cutting Head Kit, 2.63" DIA (P/N 03-0047)

Item No.	Part No.	Description	Qty
1.	21-0454	HEAD, 2.63" DIA	1
2.	28-0249	SEAL, OIL	1
3.	33-0056	SCREW, CAP, 5/16-18 X 1"	3
4.	33-0500	SCREW, SET, 1/4-20 X .31"	1
5.	33-0504	SCREW, SET, 1/4-20 X .63	1
6.	33-1958	SCREW, WEDGE	2
7.	48-0947	BLOCK, WEDGE	2

CUTTING HEAD KIT, 4" DIA (P/N 03-0048)

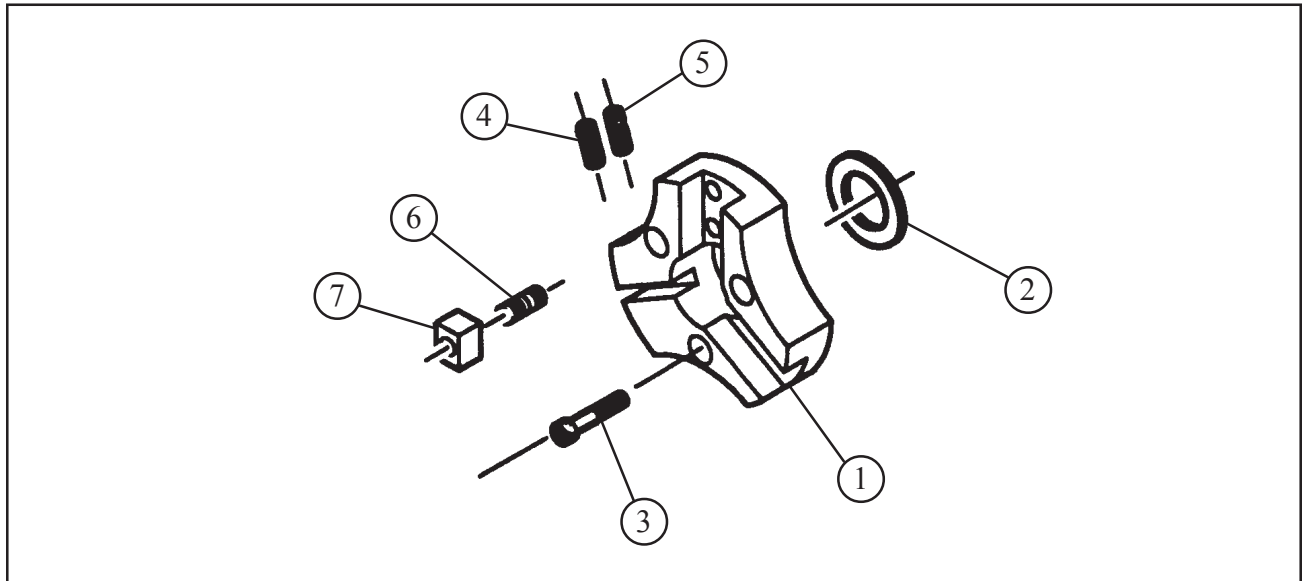

Parts List, Cutting Head Kit, 4" DIA (P/N 03-0048)

Item No.	Part No.	Description	Qty
1.	21-0455	HEAD, 4.0" DIA	1
2.	28-0249	SEAL,OIL	1
3.	33-0056	SCREW, CAP, 5/16-18 X 1"	3
4.	33-0517	SCREW, SET, 5/16-18 X .63"	2
5.	33-0518	SCREW, SET, 5/16-18 X .75"	1
6.	33-1958	SCREW, WEDGE	4
7.	48-0947	BLOCK, WEDGE	4

MANDREL ASSEMBLY (P/N 06-0415)

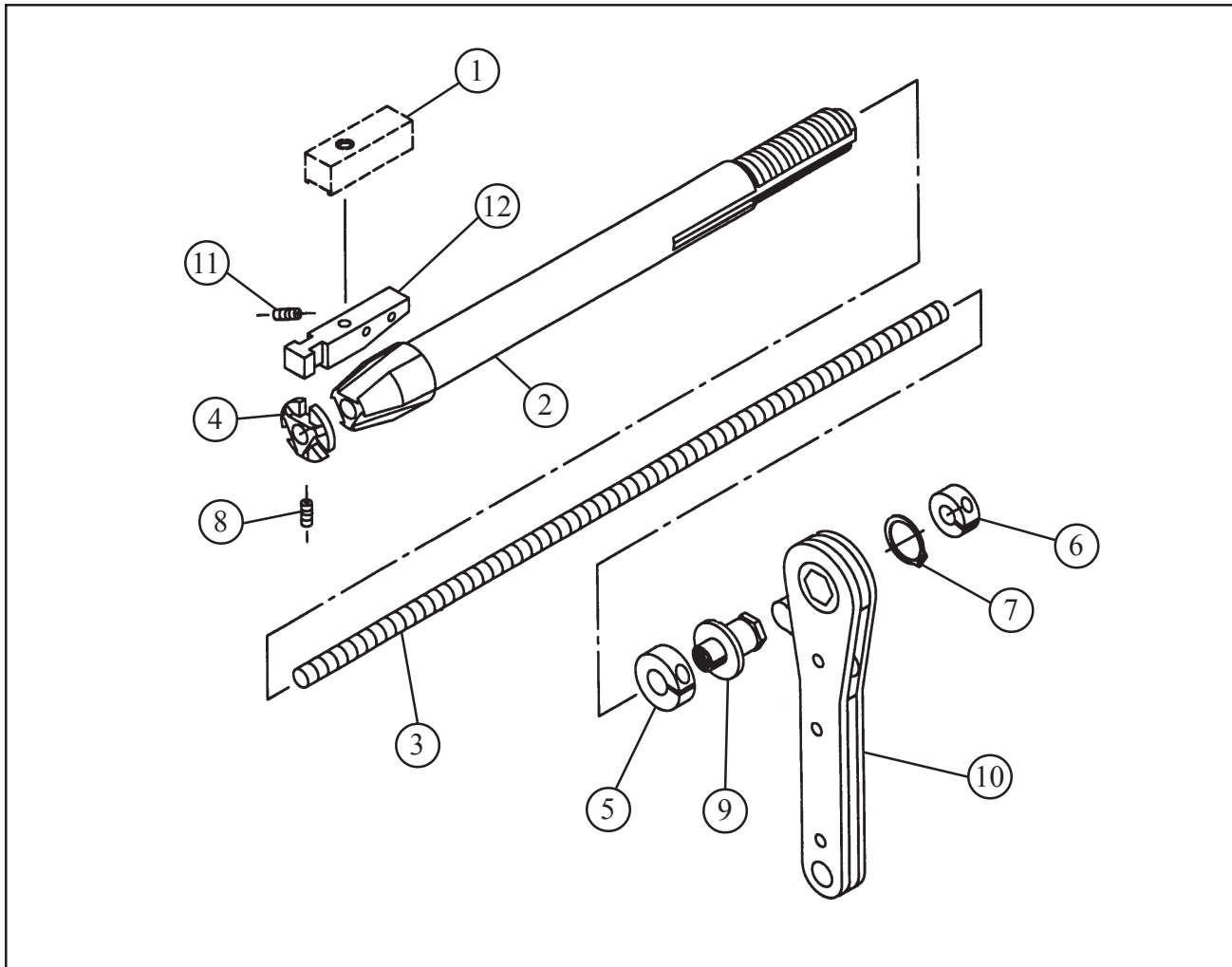

Parts List, Mandrel Assembly (P/N 06-0415)

Item No.	Part No.	Description	Qty
1.	08-xxxx	BLOCK, JAW	REF
2.	13-0424	MANDREL	1
3.	23-0295	ROD, DRAW	1
4.	24-1384	PLATE, BUTT	1
5.	30-2365	COLLAR, SHAFT	1
6.	30-2366	COLLAR, SHAFT	1
7.	30-2367	RING, RETAINING, EXTERNAL	1
8.	33-0490	SCREW, SET, #10-24 X .38", CUP POINT	1
9.	35-0445	NUT, DRAW, ROD	1

Parts List, Mandrel Assembly (P/N 06-0415)

Item No.	Part No.	Description	Qty
10.	36-0214	WRECH, RATCHET	1
11.	40-0001	SPRING, EXTENSION	5
12.	48-0964	BLOCK, RAMP, #1	3
	48-0965	BLOCK, RAMP, #2	3
	48-0966	BLOCK, RAMP, #3	3

MANDREL ASSEMBLY (P/N 06-0414)

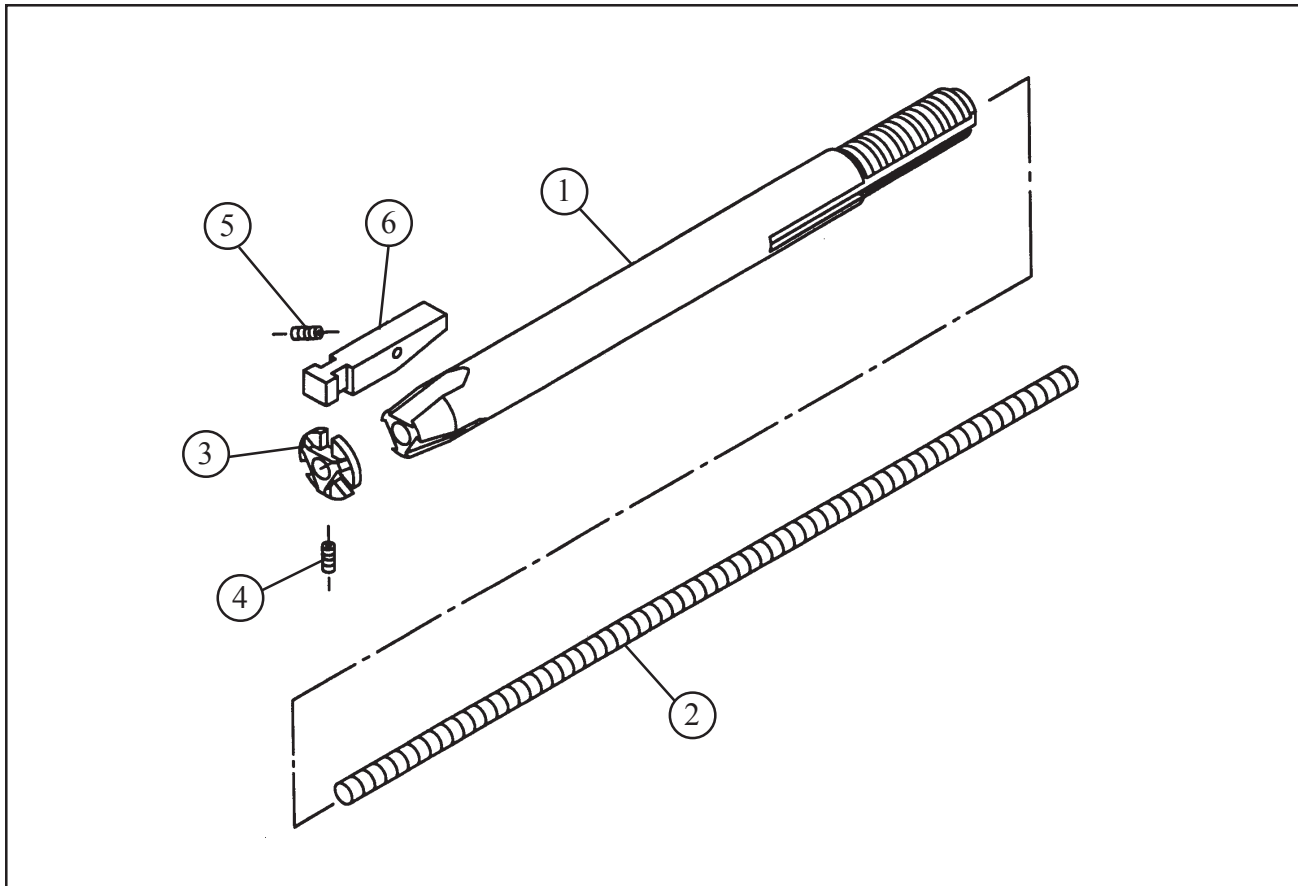

Parts List, Mandrel Assembly (P/N 06-0414)

Item No.	Part No.	Description	Qty
1.	13-0426	MANDREL	1
2.	23-0297	ROD, DRAW	1
3.	24-1462	PLATE, BUTT	1
4.	33-0489	SCREW, SET, #10-24 X .31"	1
5.	40-0108	SPRING, EXTENSION	1
6.	48-0976	BLOCK, RAMP	3
NOT SHOWN			
	35-0523	NUT, DRAW ROD, 3/8-16	1

MANDREL ASSEMBLY (P/N 06-0413)

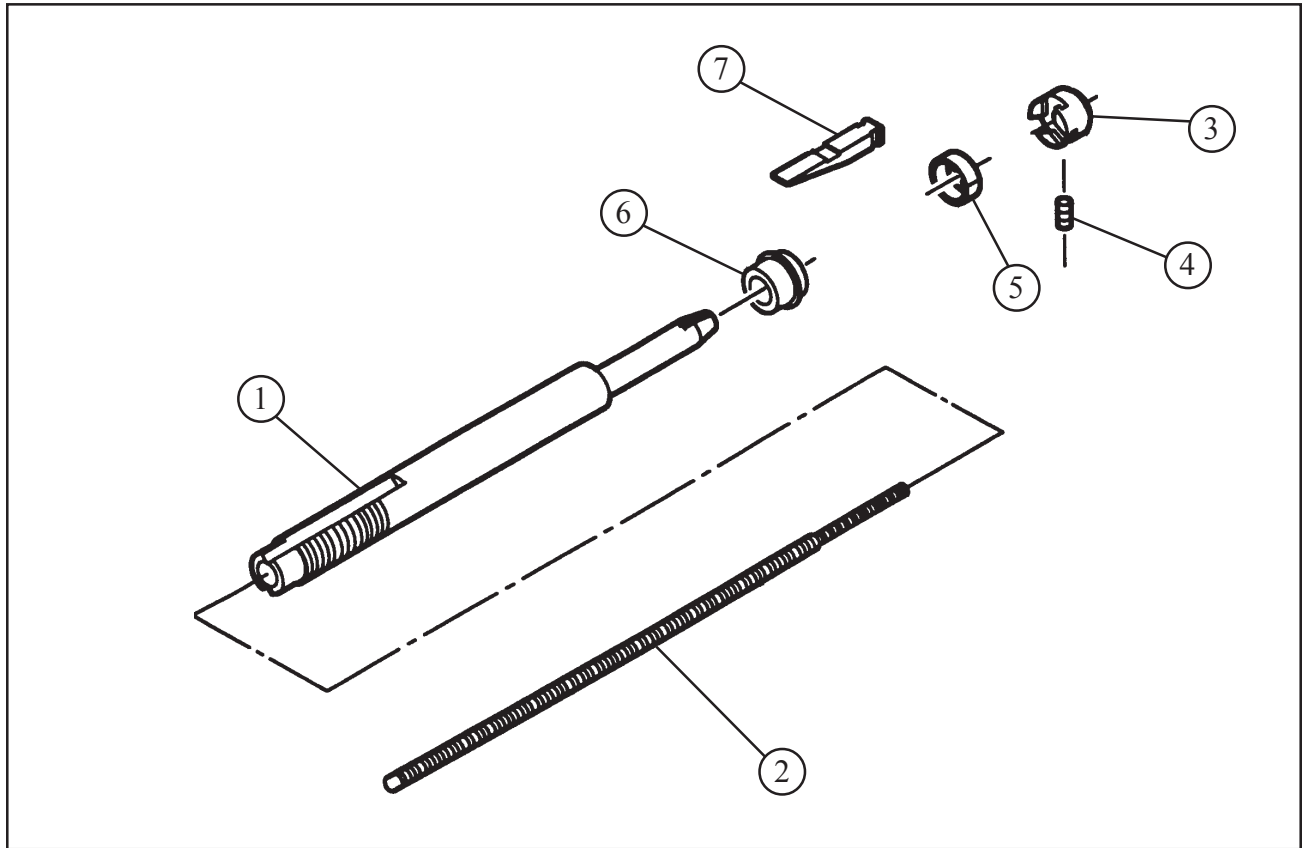

Parts List, Mandrel Assembly (P/N 06-0413)

Item No.	Part No.	Description	Qty
1.	13-0429	MANDREL	1
2.	23-0298	ROD, DRAW	1
3.	24-1463	PLATE, BUTT #1	1
	24-1464	PLATE, BUTT #2	1
4.	33-0477	SCREW, SET, #8-32 X .19	1
	33-0478	SCREW, SET, #8-32 X .25	1
5.	40-0130	SPRING, FLAT	1
	40-0136	SPRING, FLAT	1
6.	46-0437	SLEEVE, MANDREL	1
7.	48-0596	BLOCK, RAMP #1	3
	48-0597	BLOCK, RAMP #2	3
NOT SHOWN			
	35-0523	NUT, DRAW ROD, 3/8-16	1