

## TABLE OF CONTENTS

CUSTOMER MESSAGE	Inside Front Cover
SAFETY PRECAUTIONS	3
ILLUSTRATED PARTS BREAKDOWN	6
TOOL BIT RESHARPENING POLICY	Inside Back Cover
WARRANTY INFORMATION	Inside Back Cover

Copyright 2004

Proprietary property of TRI TOOL Inc.

No reproduction, use, or duplication of the information shown hereon is permitted without the express written consent of TRI TOOL Inc.

## SAFETY PRECAUTIONS

### IN GENERAL

When using rotating head cutting equipment, basic safety precautions should always be followed to reduce the risk of personal injury.

Operate this tool only in accordance with specific operating instructions.

#### **WARNING:**

Do not override the deadman switch on the power unit. Locking down, obstructing, or in any way defeating the deadman switch on the power drive unit may result in serious injury.

### DRESS CONSIDERATIONS

Use standard safety equipment. Hard hats, safety shoes, safety harnesses, protective clothes, and other safety devices should always be used when appropriate.

Use safety glasses. Do not operate cutting tools without eye protection.

Dress properly. Do not wear loose clothing or jewelry. They can be caught in rotating and moving parts. Avoid slippery floors or wear nonskid footwear. If you have long hair, wear protective hair covering to contain it.

### WORK AREA

Keep the work area clean. Cluttered work areas and benches invite injuries.

Consider the work area environment. Keep the area well lit. Keep electrical cords, cables, rags, rigging straps, and etc. clear of rotating equipment. Do not use power-cutting tools in the presence of flammable liquids and gasses.

Keep visitors away. Do not let visitors or untrained personnel at or near operating tools. Enforce eye protection requirements for all observers.

Do not over reach. Keep proper footing at all times.

Stay alert. Watch what you are doing. Use common sense. Do not operate tools when you are tired.

### TOOL CARE

Maintain tools with care. Keep tools in good operating condition. Sharp tool bits perform better and safer than dull tool bits. Well maintained tools function properly when needed.

Check for damaged parts. If a tool has malfunctioned, been dropped or hit, it must be checked for damage. Run no-load tests and feed function checks. Do a complete visual inspection.

Electric motors. Use only with proper AC voltage power sources and observe all normal electric shock hazard procedures.

Do not abuse power and control cords. Pulling or running over cords and cables can result in electrical shock hazards and malfunctions. Keep control and power cords out of all cutting fluids and water.

Hydraulic drives. Observe proper procedures for electrically driven power sources. Avoid damage to hydraulic lines. Keep quick-disconnects clean. Grit contamination causes malfunctions.

Air tools. Check the exhaust muffler. Broken or damaged mufflers can restrict air flow or cause excessive noise. Use air motors only with a filtered, lubricated and regulated air supply. Dirty air, low-pressure air or over pressure air will cause malfunctions, including delayed starting.

### AREA EQUIPMENT

Secure work. Whenever possible use clamps, vises, chains and straps to secure pipe.

Make sure the tool is secured; it is safer to have both hands free to operate the tool.

### TOOL USE

Use the right tool and tool bit for the job. Do not use a tool, which is incorrect for the job you are doing.

Keep the tool bits fully engaged in the tool bit holders. Loose bits are a safety hazard.

Disconnect power supply during setup and maintenance. Use all 'Stop' or Shut off' features available when changing or adjusting tool bits, maintaining the tool, or when the tool is not in use.

Remove adjusting keys and wrenches before applying power to the equipment. Develop a habit of checking the tool before turning it on to make sure that all keys and wrenches have been removed.

Do not force tools. Tools and tool bits function better and safer when used at the feed and speed rate for which they were designed.

Do not reach into rotating equipment. Do not reach into the rotating head stock to clear chips, to make adjustments, or to check surface finish. A machine designed to cut steel will not stop for a hand or an arm.

Handle chips with care. Chips have very sharp edges and are hot. Do not try to pull chips apart with are hands; they are very tough.

Avoid unintentional starts. Do not carry or handle tools with your hand on the operating switches or levers. Do not lay the tool down in a manner that will start the drive. Do not allow the tool to flip around or move when adjusting or changing tool bits.

Store idle tools properly. Disconnect tools from the power source and store in a safe place. Remove tool bits for safe handling of the tool.

**ILLUSTRATED PARTS BREAKDOWN**

**WELD CROWN REDUCTION MODULE (P/N 82-0192)**

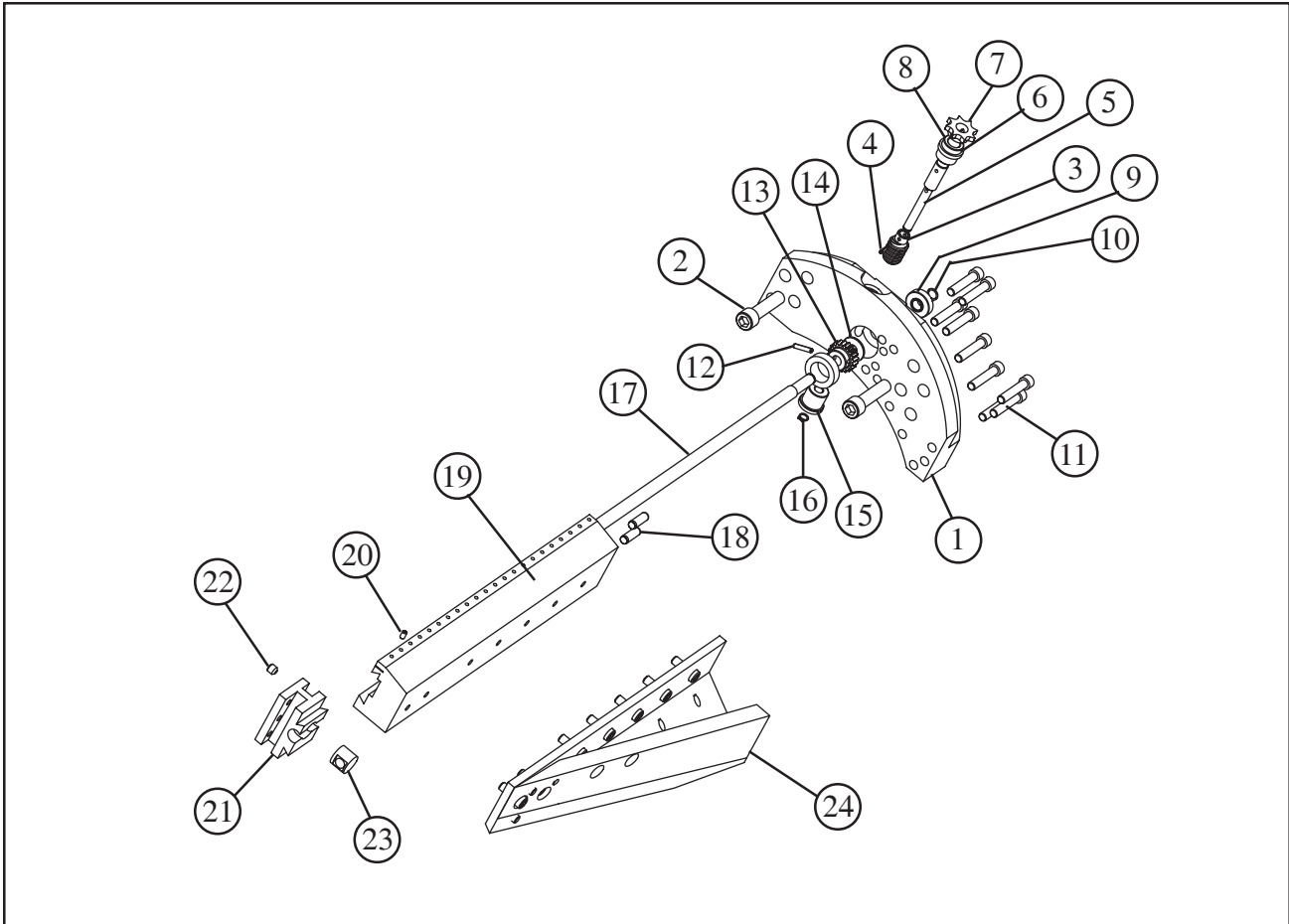

Parts List, Weld Crown Reduction Module (P/N 82-0192)

Item No.	Part No.	Description	Qty
1.	47-1730	BRACKET	1
2.	33-0073	SCREW, CAP, 3/8-16 X 1 1/2"	2
3.	39-0036	GEAR, WORM	1
4.	32-0097	PIN, ROLL, 3/32 DIA. X 3/8"	1
5.	20-1102	SHAFT	1
6.	45-0396	BUSHING	1

## Parts List, Weld Crown Reduction Module (P/N 82-0192) Continued

<b>Item No.</b>	<b>Part No.</b>	<b>Description</b>	<b>Qty</b>
7.	38-0023	SPROCKET, 8 PT	1
8.	32-0017	PIN, ROLL, 3/32 DIA. X 5/8"	1
9.	29-0206	BEARING	1
10.	30-0110	RING, RETAIN, EXT., 5/16 OD, SST	1
11.	33-0043	SCREW, CAP, 1/4-20 X 1 1/4"	9
12.	32-0025	PIN, ROLL, 1/8 DIA. X 5/8"	1
13.	39-0438	GEAR	1
14.	34-0108	WASHER, THRUST, 5/16" X 3/4" X 1/16"	1
15.	45-0395	BUSHING	1
16.	30-0160	RING, RETAIN, EXT. 1/4" OD	1
17.	33-2549	SCREW, FEED	1
18.	32-0140	PIN, DOWEL, 1/4 DIA. X 3/4"	2
19.	47-1731	BRACKET, DOVETAIL	1
20.	33-0467	SCREW, SET, #6-32 X 1/4", CUP PT	22
21.	48-2123	BOCK, TOOL HOLDER	1
22.	33-0499	SCREW, SET, 1/4-20 X 1/4", CUP PT	6
23.	35-0257	NUT, FEED	1
24.	47-1732	GUSSET ASSEMBLY	1

GUSSET ASSEMBLY (P/N 47-1732)

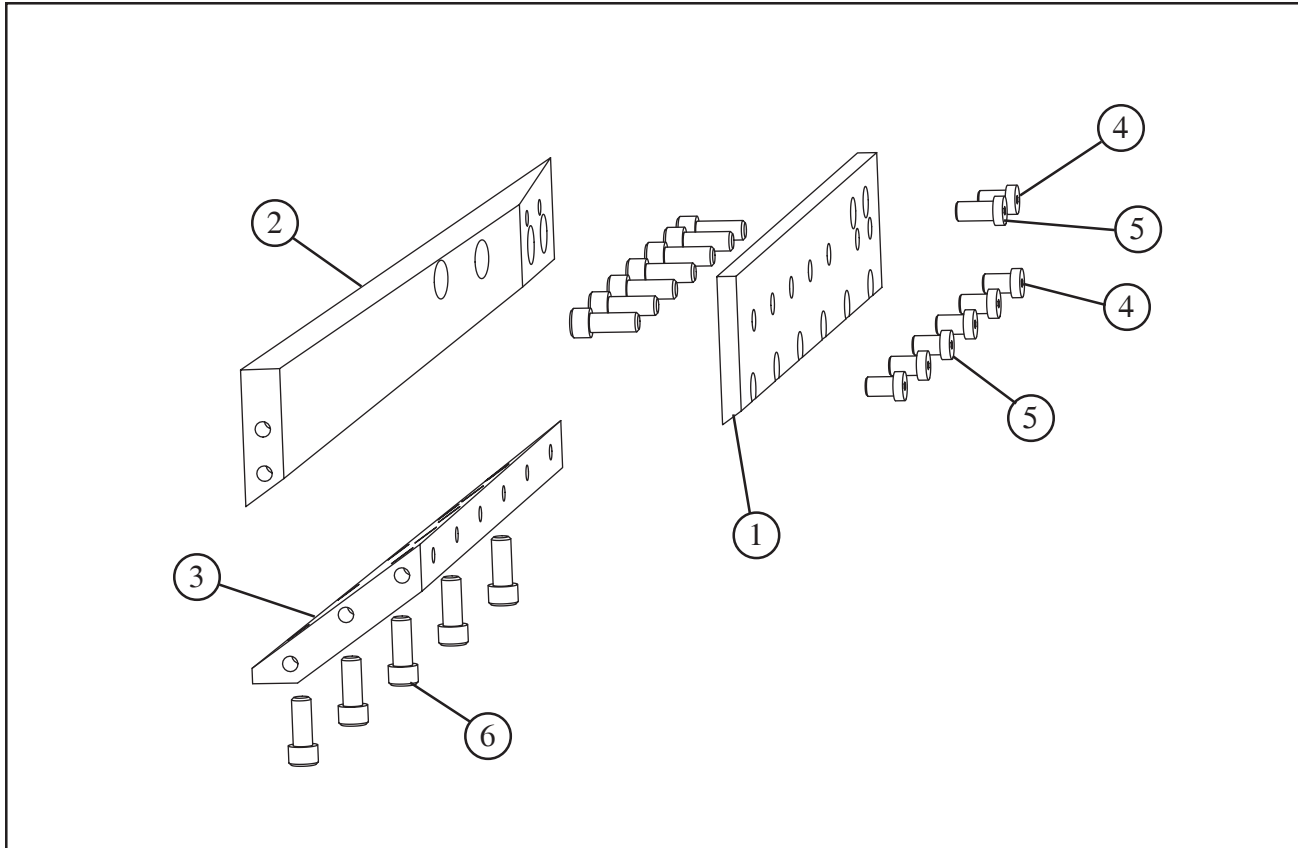

Parts List, Gusset Assembly (P/N 47-1732)

Item No.	Part No.	Description	Qty
1.	24-2427	PLATE	1
2.	24-2429	PLATE	1
3.	24-2428	PLATE	1
4.	33-2551	SCREW, LOW CAP, 1/4-20 X 3/8"	2
5.	33-1227	SCREW, LOW CAP, 1/4-20 X 1/2"	6
6.	33-0039	SCREW, CAP, 1/4-20 X 5/8"	12