

## TABLE OF CONTENTS

CUSTOMER MESSAGE	Inside Front Cover
SAFETY PRECAUTIONS	3
GENERAL DESCRIPTION	6
SPECIFICATIONS	7
COMPONENET OVERVIEW	10
SET-UP AND INSTALLATION	11
OPERATION	15
MAINTENANCE	17
STORAGE	22
CUTTING SPEEDS AND FEEDS	23
COLLETS	24
TOOL BITS	26
TROUBLE SHOOTING	31
ACCESSORIES	33
ILLUSTRATED PARTS BREAKDOWN	35
TOOL BIT RESHARPENING POLICY	Inside Back Cover
WARRANTY INFORMATION	Inside Back Cover

Copyright 2011  
Proprietary property of TRI TOOL Inc.  
No reproduction, use, or duplication of the information  
shown hereon is permitted without the express written  
consent of TRI TOOL Inc.

## SAFETY PRECAUTIONS

### IN GENERAL

When using rotating head cutting equipment, basic safety precautions should always be followed to reduce the risk of personal injury.

Operate this tool only in accordance with specific operating instructions.

#### **WARNING:**

Do not override the deadman switch on the power unit. Locking down, obstructing, or in any way defeating the deadman switch on the power drive unit may result in serious injury.

### DRESS CONSIDERATIONS

Use standard safety equipment. Hard hats, safety shoes, safety harnesses, protective clothes, and other safety devices should always be used when appropriate.

Use safety glasses. Do not operate cutting tools without eye protection.

Dress properly. Do not wear loose clothing or jewelry. They can be caught in rotating and moving parts. Avoid slippery floors or wear nonskid footwear. If you have long hair, wear protective hair covering to contain it.

### WORK AREA

Keep the work area clean. Cluttered work areas and benches invite injuries.

Consider the work area environment. Keep the area well lit. Keep electrical cords, cables, rags, rigging straps, and etc. clear of rotating equipment. Do not use power-cutting tools in the presence of flammable liquids and gasses.

Keep visitors away. Do not let visitors or untrained personnel at or near operating tools. Enforce eye protection requirements for all observers.

Do not over reach. Keep proper footing at all times.

Stay alert. Watch what you are doing. Use common sense. Do not operate tools when you are tired.

### **TOOL CARE**

Maintain tools with care. Keep tools in good operating condition. Sharp tool bits perform better and safer than dull tool bits. Well maintained tools function properly when needed.

Check for damaged parts. If a tool has malfunctioned, been dropped or hit, it must be checked for damage. Run no-load tests and feed function checks. Do a complete visual inspection.

Electric motors. Use only with proper AC voltage power sources and observe all normal electric shock hazard procedures.

Do not abuse power and control cords. Pulling or running over cords and cables can result in electrical shock hazards and malfunctions. Keep control and power cords out of all cutting fluids and water.

Hydraulic drives. Observe proper procedures for electrically driven power sources. Avoid damage to hydraulic lines. Keep quick-disconnects clean. Grit contamination causes malfunctions.

Air tools. Check the exhaust muffler. Broken or damaged mufflers can restrict air flow or cause excessive noise. Use air motors only with a filtered, lubricated and regulated air supply. Dirty air, low-pressure air or over pressure air will cause malfunctions, including delayed starting.

### **AREA EQUIPMENT**

Secure work. Whenever possible use clamps, vises, chains and straps to secure pipe.

Make sure the tool is secured; it is safer to have both hands free to operate the tool.

### **TOOL USE**

Use the right tool and tool bit for the job. Do not use a tool, which is incorrect for the job you are doing.

Keep the tool bits fully engaged in the tool bit holders. Loose bits are a safety hazard.

Disconnect power supply during setup and maintenance. Use all 'Stop' or Shut off' features available when changing or adjusting tool bits, maintaining the tool, or when the tool is not in use.

Remove adjusting keys and wrenches before applying power to the equipment. Develop a habit of checking the tool before turning it on to make sure that all keys and wrenches have been removed.

Do not force tools. Tools and tool bits function better and safer when used at the feed and speed rate for which they were designed.

Do not reach into rotating equipment. Do not reach into the rotating head stock to clear chips, to make adjustments, or to check surface finish. A machine designed to cut steel will not stop for a hand or an arm.

Handle chips with care. Chips have very sharp edges and are hot. Do not try to pull chips apart with are hands; they are very tough.

Avoid unintentional starts. Do not carry or handle tools with your hand on the operating switches or levers. Do not lay the tool down in a manner that will start the drive. Do not allow the tool to flip around or move when adjusting or changing tool bits.

Store idle tools properly. Disconnect tools from the power source and store in a safe place. Remove tool bits for safe handling of the tool.

## GENERAL DESCRIPTION

The 600SBCM Low Profile Clamshell is a split-frame pipe lathe for severing and beveling in-line pipe with minimal radial and axial clearances. Model 601SBCM has a range of 1/8" through 1" pipe. Model 602SBCM has a range of 1" through 2" pipe. Model 603SBCM has a range of 1 1/4" pipe through 3" tube.

Easily adjustable precision bearing surfaces preload and stabilize the rotating head to provide long life, low maintenance, stability and precision.

The Clamshell splits into two halves for mounting on closed loop systems. All parts are secured to the two halves to avoid loss of parts and provide maximum ease of handling.

The machine is equipped with self-centering collets.

Dual dovetail tool modules with auto-feed sprockets and adjustable gib provide maximum maintainability, life and operator safety with minimum operator training.

The auto-feed star sprockets provide .003" (.08 mm) of radial feed per revolution for a controlled depth of cut.

Drive worm, worm gears and bearing surfaces are covered for operator safety.

Operator controls are away from the rotating headstock for safety.

Modular design concepts provide quick, easy maintenance and maximum versatility in drive and tooling options.

Detachable Bayonet type motor provides maximum handling ease and low axial clearance. A flex drive shaft is also available to bring the motor away from the tool.

# SPECIFICATIONS

Weight:

Base Machine	4 lbs. (1.81 kg)
Motor	5.35 lbs. (2.43 kg)

Main Drive Gear: Worm Drive

Motor Mount: Bayonet Type

Clamping: Collet Type

Pipe Size Range: 1/8" through 1" Pipe

Tool Bit Feed Rate: .003" (.08 mm) per revolution

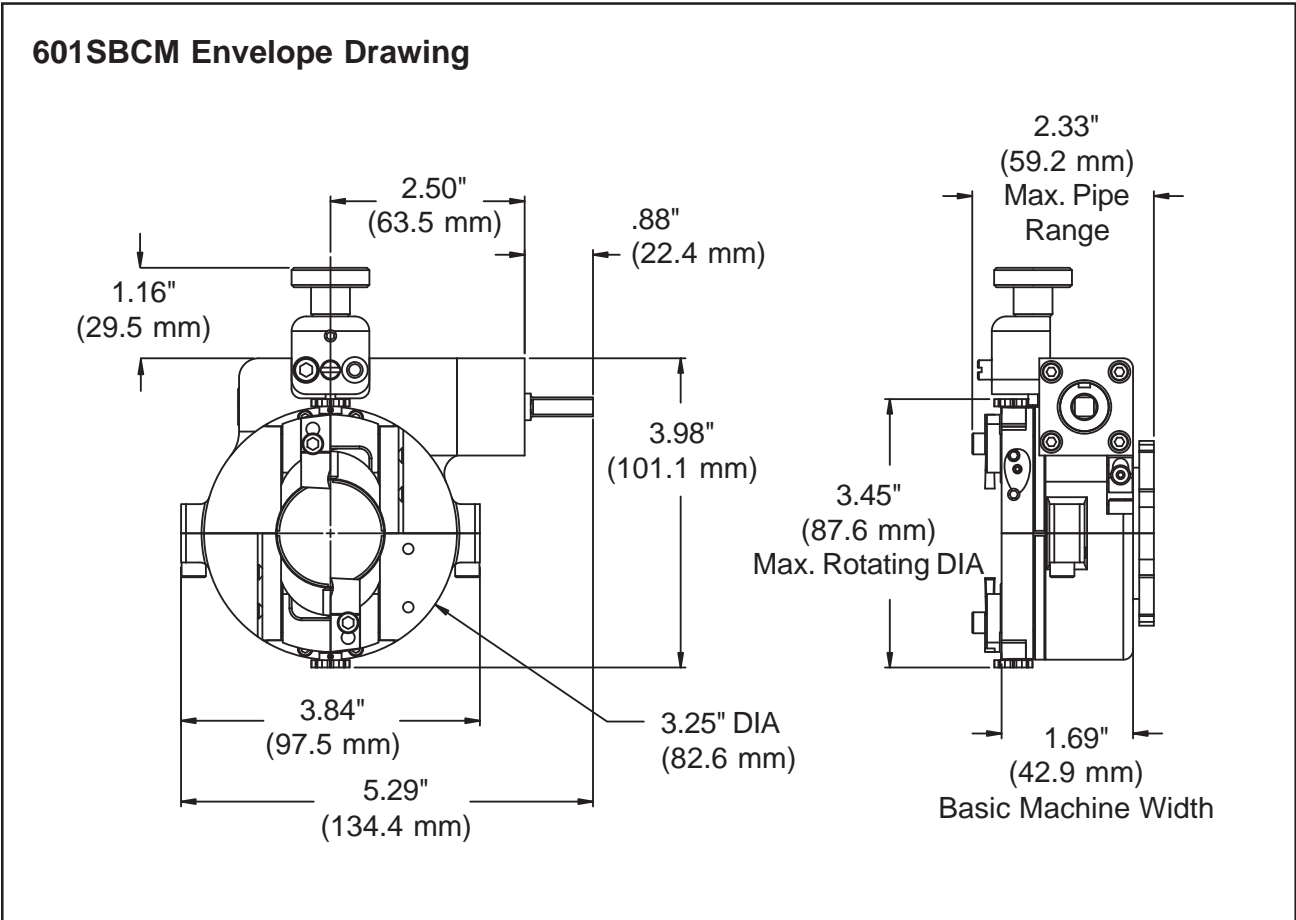

Weight:

Basic Machine	6.0 lbs. (2.72 kg)
Motor	5.35 lbs. (2.43 kg)

Main Drive Gear: Worm Drive

Motor Mount: Bayonet Type

Clamping: Collet Type

Pipe Size Range: 1" through 2" Pipe

Tool Bit Feed Rate: .003" (.08 mm) per revolution

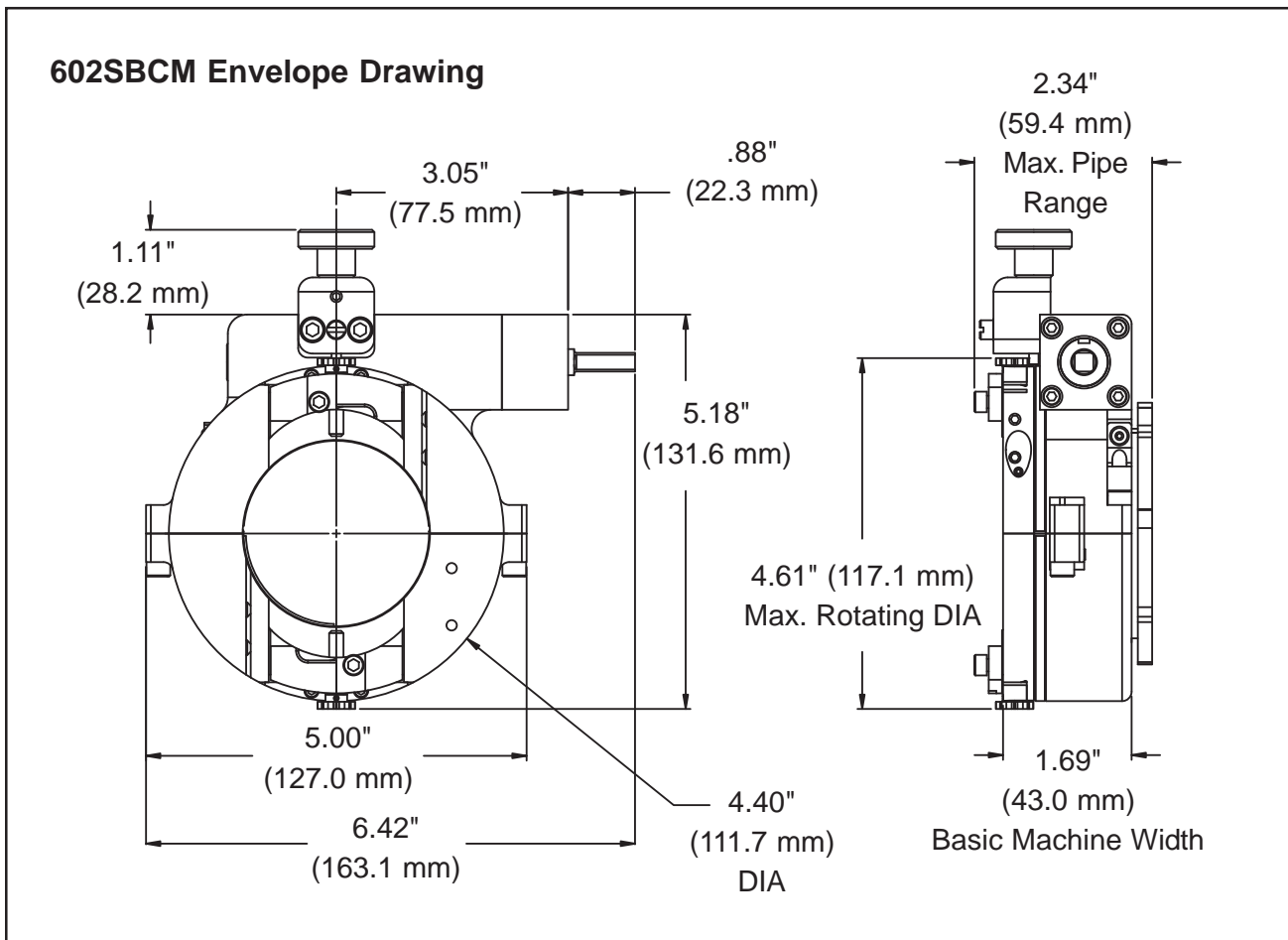

# Model 600SBCM Clamshell

Weight:

Basic Machine: 6.2 lbs (2.81 kg)  
Motor: 5.35 lbs (2.43 kg)

Main Drive Gear: Worm Drive

Motor Mount: Bayonet Type

Clamping: Collet Type

Pipe Size Range: 1 1/4" pipe through 3" tube

Tool Bit Feed Rate: .003" (.08 mm) per revolution

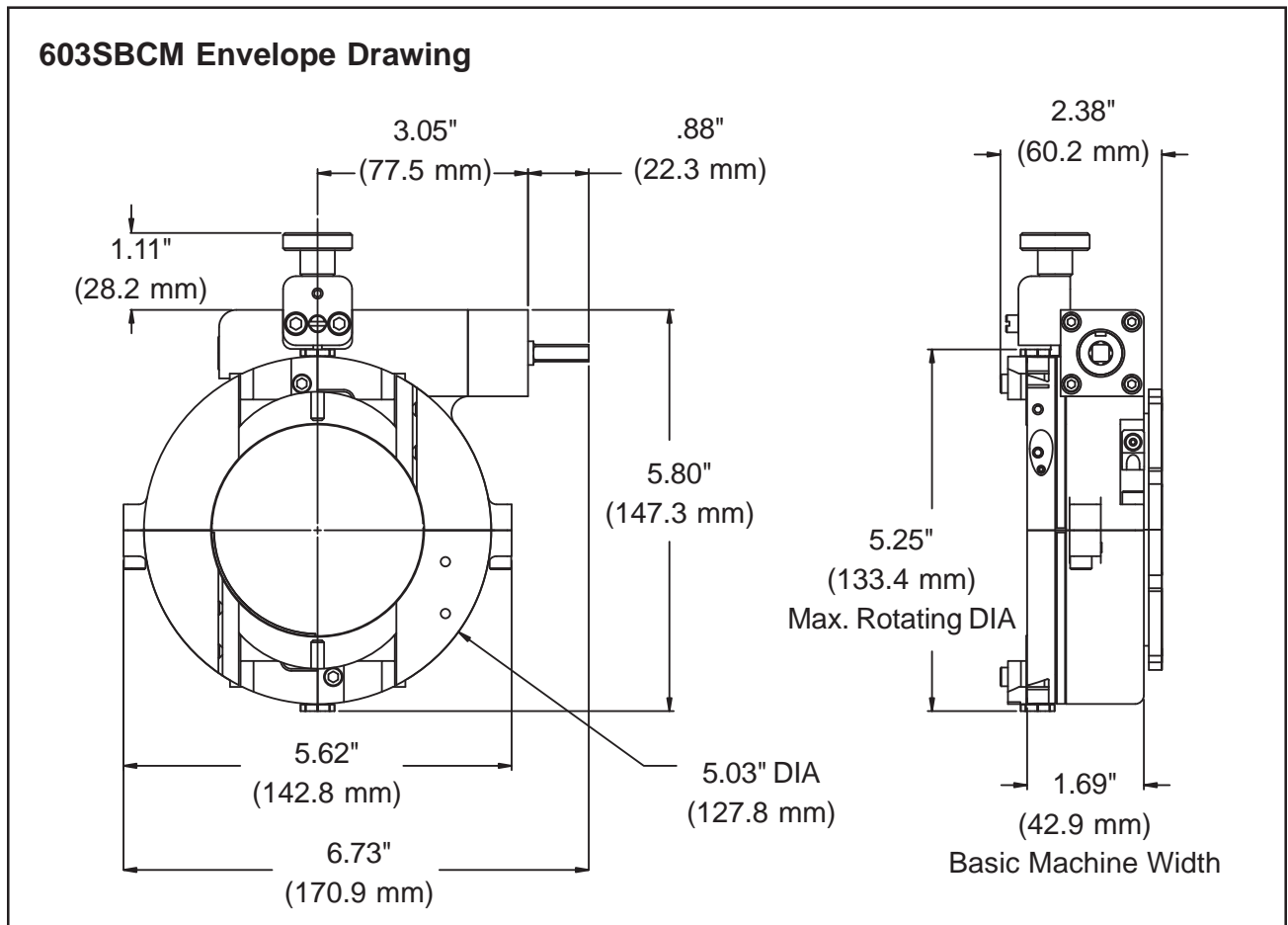

## COMPONENT OVERVIEW

### CLAMSHELL

The clamshell is the main part of the machine. Contained within it is the collet that secures the clamshell to the pipe, two tool bit mounting blocks and feed mechanisms, a tripper pin that is engaged or disengaged to either feed or not feed the tool bits in to the pipe, and the drive shaft to rotate the machining head with mounting provisions for the air motor. When engaged, the tripper pin causes the tool bit to advance .003 inches every revolution of the machine.

### AIR MOTOR

The power to rotate the machining head comes from the air motor. The motor can either be directly attached to the clamshell or connected to it through a flexible shaft. A spring-energized twist-lock coupling connects these components together. There is a twist-action throttle on the handle of the air motor for controlling its speed.

### FLEXIBLE DRIVE SHAFT

If space restrictions in the working area do not allow the air motor to be directly attached to the clamshell, then the flexible drive shaft can be used. The flexible drive shaft is 18" inches long and has a spring-energized twist-lock coupling at each end.

### TOOL BITS

The rotating head of the clamshell has holders that allow two tool bits to be used simultaneously. There are a number of tool bits designed for use with this machine. Tool bit selection depends on what kind of cut is being made. Please reference the "Tool Bits" section for further guidance. An 8-32 hex-socket cap screw is used to secure a tool bit to the tool holder. A 9/64-inch hex wrench is used to remove the cap screw for tool bit replacement.

### COLLETS

Four wedge-type collet pieces are used as a set in the clamshell to secure it to the pipe. A collet set is specially sized to match the size pipe being machined. Each collet piece is secured to the clamshell with a 4-40 hex-socket button-head cap screw. A 1/16-inch hex wrench is used to remove the cap screw for collet piece replacement.

## SET-UP AND INSTALLATION

### HAND TOOLS

- Feed Sprocket Driver
- 9/64" Hex Wrench for Tool Bit Screws
- 5/32" Hex Wrench for Clamshell Screws
- One (1) Spanner Wrench and Torque Wrench for Collet Nut
- Ratchet Wrench and 1/4" Square Socket for Drive Shaft
- 1/16" Hex Wrench for Collets
- 3/32" Hex Wrench for Tool Modules Adjustment Screws
- 7/64" Hex Wrench for Bearing Locking Screws
- 5/64" Hex Wrench for Bearing Adjustment Screws
- 5/16" Hex Wrench for Pin Removal Tool

### SET UP

**NOTE:**

All areas of the tool should be checked to be clean and lubricated before use. Use EP grease on sliding surfaces and oil, 10-weight or less, on all other surfaces.

Configure the clamshell for the pipe size being machined using the following procedure:

Determine the size of the pipe to be machined.

**NOTE:**

Refer to the 'Collets' section for collet set sizes to use.

Determine what size collet is installed in the clamshell.

When the collet needs to be replaced, a 1/16" hex wrench can be used to remove the button head cap screw that secures them in the clamshell. It may be necessary to split the clamshell in two to accomplish this.

Attach the replacement collet pieces to the clamshell. Orient the collet pieces so that the thick side is toward the collet nut threads. Tighten the button head cap screws so the collet is retained but moves freely.

Install the tool bits for the cut to be made using the following procedure:

**NOTE:**

Refer to the 'Tool Bits' section for tool bits available.

Install the tool bits in to the tool blocks on the machine using the #8-32 socket-head cap screws. Tighten the socket-head cap screws using a 9/64" hex wrench.

Fully retract the two (2) tool blocks using the sprocket driver.

Assure that the necessary services are available: Air Supply, 32 CFM at 90 PSI, lube oil added at 2 to 4 drops per minute. Cutting fluid, if permitted. (Cutting speeds will need to be reduced if no cutting fluid is used.)

## INSTALLATION

**NOTE:** Assure tool blocks are fully retracted.

If it is possible to install the assembled tool over the end of the pipe, skip to "Securing the clamshell to the pipe". If it is not possible to install the assembled tool over the end of the pipe, use the following procedure.

Splitting the tool and reassembling it around the pipe:

Remove the collet nut.

Use the ratchet wrench on the drive shaft to line up the two (2) halves of the rotating gear portion of the machine with the stationary housing portion making sure the top of the cap screws are in-line of each other.

Unscrew the four (4) #10-24 cap screws that hold the two (2) halves together. Note that the screws location does not allow them to fall out, even when fully retracted. The two (2) halves should easily separate from each other.

**NOTE:** When separating the clamshell, loosen the gear splitline screws first. When reassembling the clamshell, tighten the housing splitline screws first.

Ensure the mating surfaces on both halves of the clamshell are clear of any dirt or debris.

Position the two (2) halves on the pipe, mate them together, and tighten the four (4) #10-24 cap screws using a 5/32" hex wrench.

Place the two (2) halves of the collet nut together around the pipe and screw it into the clamshell, but do not tighten it.

Securing the clamshell to the pipe:

Position the clamshell on the pipe so that the tool bits will cut in the desired location and allow enough clearance for the air motor. Use the flexible drive shaft if space for the air motor is not available.

Tighten the collet nut with the spanner wrench and hold the machine in place with the torque wrench. Verify that the clamshell is securely clamped to the pipe.

### SETTING THE TOOL BIT POSITION

**NOTE:** The tool bit will move .025" for one (1) full turn of the feed sprocket.

Using the feed sprocket wrench, lower the severing tool bit until it touches the pipe. Turn the wrench in the opposite direction until the backlash in the feed screw is removed.

**NOTE:** A slight increase in the effort required to turn the wrench will be felt but the tool bit will not move.

Raise the severing tool bit three (3) turns of the feed sprocket. When cutting 1" or over- sized piping this may not be possible. Turn the wrench in the opposite direction until the backlash in the feed screw is removed.

Align the feed sprocket so two (2) opposing teeth are in-line with the pipe.

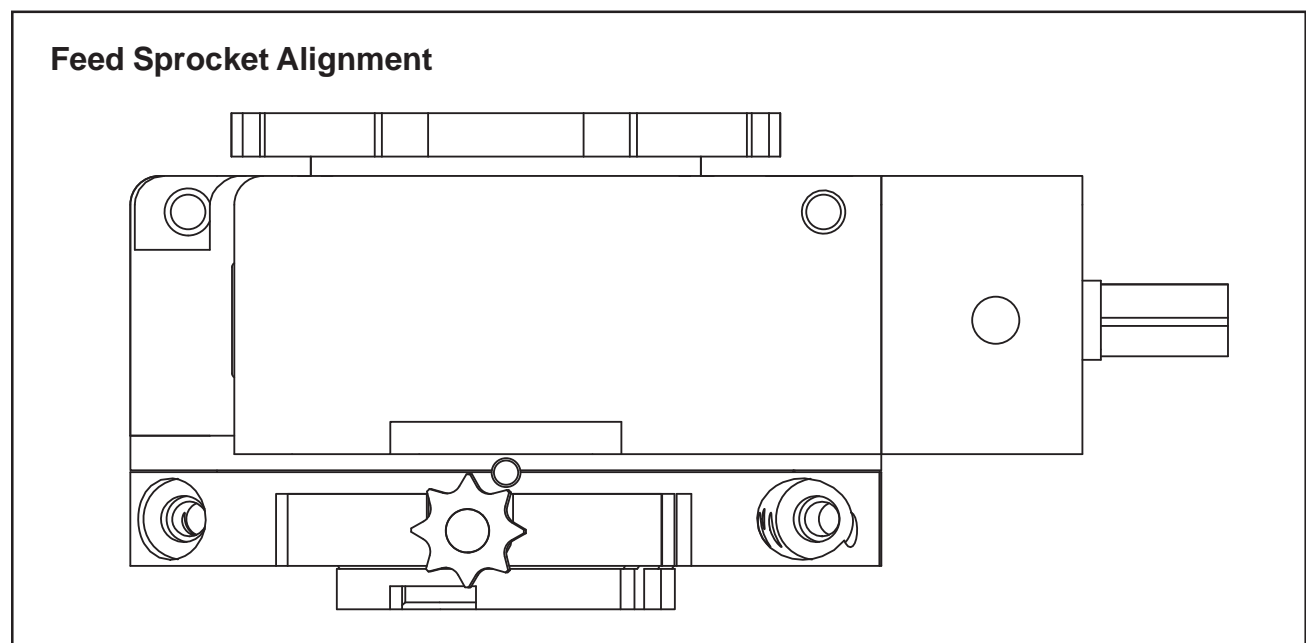

Repeat these steps for the beveling bit, except raise it three and one-half (3 1/2) turns off the surface of the pipe.

With the tripper pin disengaged, use the ratchet wrench to slowly rotate the head.

Verify that both tool bits are able to clear the diameter of the pipe without contacting anything. If it appears that either tool bit will contact the pipe surface, stop the head and make the appropriate adjustments (raising both tool bits by the same amount, removing the interference, repositioning the machine, etc.).

With the tripper pin engaged, slowly rotate the head one (1) revolution. Observe that the tripper pin moves each of the feed sprockets correctly.

### **ATTACHING THE AIR MOTOR**

Attach the air motor to the clamshell, either directly or through the flexible drive shaft.

Connect the air supply to the air motor.

## OPERATION

**NOTE:**

Each tool bit will be lowered in to the cut .003 inches every time it passes the tripper pin, if the tripper pin is engaged.

**CAUTION:**

When an installed pipe is severed, it may move. Secure the pipe on both sides of the sever line to prevent movement and increase safety.

**CAUTION:**

Verify that the tool block feed sprockets are correctly aligned to prevent damage during operation.

Engage the tripper pin to begin feeding the tool bit into the pipe.

Slowly run the tool blocks around the pipe and verify tool bit positioning and clearance.

Increase the speed of the air motor to full speed.

Watch the cutting action as the tool bits begins cutting the pipe to make sure everything is normal. If looseness or another problem is seen, stop the machine and fix the problem before continuing.

Start applying cutting fluid, if applicable to the application.

Monitor the temperature of the body of the tool. If it becomes excessively hot then the main bearing is too tight and requires adjustment. Reference the 'Maintenance' section of this manual for instruction on 'Main Bearing Adjustment'.

If the chip tangles in the head, disengage the tripper pin for two (2) or three (3) revolutions. Stop the machine and remove the chips.

### Removal:

Using the feed sprocket driver, retract the tool bits until they are clear of the pipe surface.

Remove the tool from the pipe.

If the machine must be disassembled to remove it from the pipe, use the following procedure:

Remove the air motor and flexible driveshaft if present.

Use the ratchet wrench to rotate the head until the split lines of the head and the clamshell match.

Retract the tool bits.

Loosen the collet nut using the spanner wrench and torque wrench.

If the clamshell must be split to remove the tool from the pipe:

Remove the collet nut.

Unscrew the four (4) #10-24 cap screws holding the two (2) halves of the clamshell together using the 5/32" hex wrench.

**NOTE:** The cap screws will not fall out of the clamshell when fully unscrewed.

Remove the two (2) halves of the tool from the pipe.

Unless the tool is going to be immediately installed on another pipe location, reassemble the two (2) halves of the tool and tighten the four (4) screws to 5 to 7 ft-lbs.

Reinstall the collet nut.

**CAUTION:** If the tool is going to be used immediately for another cut, allow the clamshell to cool before beginning the next cut.

## MAINTENANCE

All components should be clean and lubricated before use and storage.

Air supply for the Model 600SBCM requires an adequate filter/lubricator (FRL) to be used.

**NOTE:**

The motor warranty is void if damage occurs from contaminated air or lack of lubrication.

### BEFORE EACH USE

Adjust tool module slides.

If the clamshell is operated in such a manner that the Tool Block collects debris while cutting, the tool block and the feed screws should be cleaned before each cutting operation.

### DAILY

Daily maintenance should include a visual inspection of all parts for damage due to chips, impact or improper use.

Repair or replace broken or damaged parts as necessary.

Wipe the machine clean of cutting fluids, dirt and grime. Coat it with a light film of oil.

### EVERY 20 HOURS OF OPERATION

Check the adjustment of the main bearing pre-load. It should only take a light force to rotate the drive shaft with the ratchet wrench.

Check the adjustment of the tool module slides and gib rails.

Lubricate the male and female tool slides and the feed screw.

### EVERY 40 HOURS OF OPERATION

Thoroughly clean and lubricate main gear, drive gear, male and female tool slides, feed screws and tripper block assembly.

**TRIPPER PIN REMOVAL**

Loosen the Half Dog Set Screw (P/N 33-0954).

Loosen the Ball Plunger (P/N 30-0125).

Remove the Tripper Shaft assembly (P/N 14-0097) from the Tripper Block Assembly (P/N 47-1521).

Remove the Cap Screw (P/N 33-2649) and the Knob (P/N 42-0217) from the Tripper Shaft (P/N 20-0803).

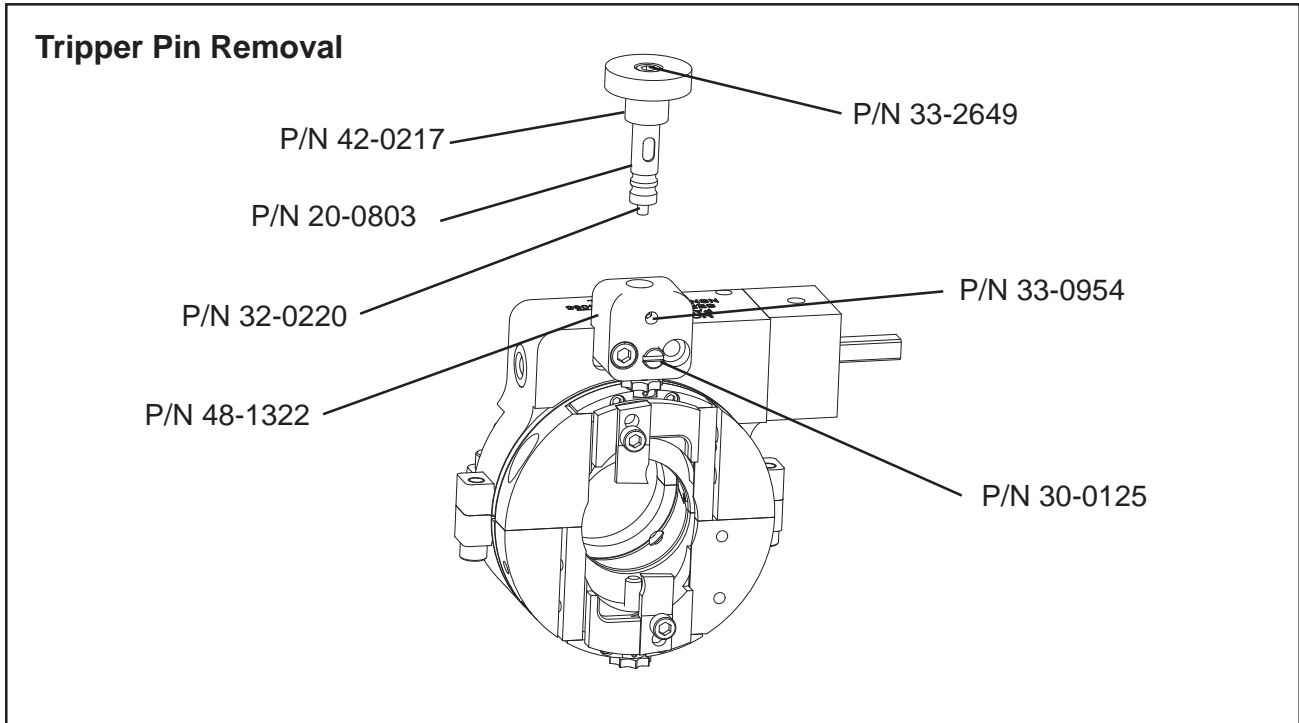

Insert the Tripper Shaft into the Pin Removal Tool (Optional Accessory P/N 08-0804).

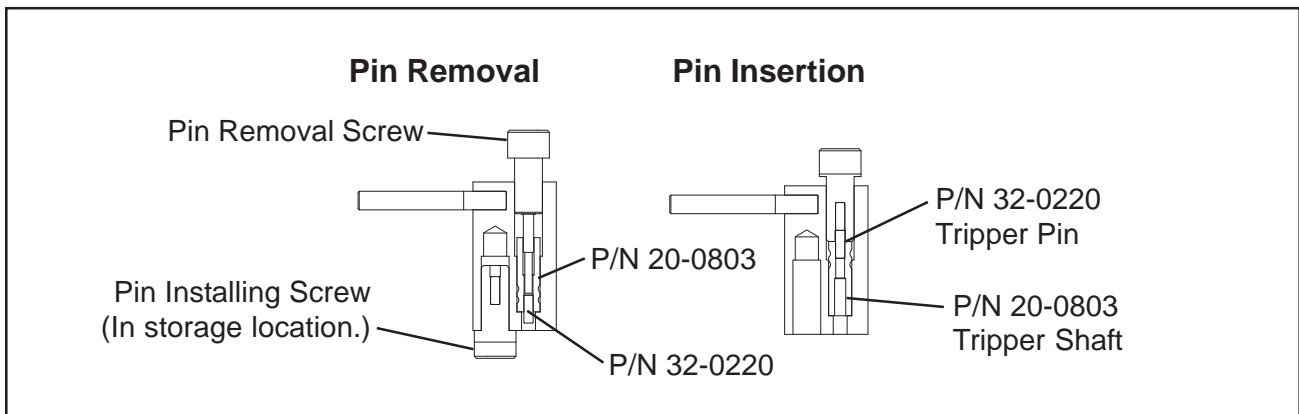

Thread the Pin Removal Screw into the block, tighten with a 5/16" hex wrench (P/N 36-0011) until the pin is removed.

## **NEW TRIPPER PIN INSTALLATION**

Unscrew pin removal screw.

Remove Tripper Shaft (P/N 20-0803) from tool.

Start Dowel Pin (P/N 32-0220) in Tripper Shaft, insert tapered end.

Insert Tripper Shaft and Dowel Pin into Tool.

Thread Pin Installing Screw into Tool. Tighten screw until it stops. This will set the pin to the proper depth.

Remove Pin Installing Screw.

Remove Tripper Shaft and Pin.

Reassemble Tool with Pin Removal and Installing Screws.

## **REASSEMBLE TRIPPER SHAFT ASSEMBLY**

Apply Loctite 242 to Cap Screw (P/N 33-2649).

Insert Tripper Shaft Assembly in Tripper Block (P/N 48-1322).

Apply 242 Loctite to H-Dog Set Screw (P/N 33-0954). Screw in all the way and back off 1/4 turn.

Apply 242 Loctite to Ball Plunger Screw (P/N 30-0125). Screw in all the way and back off 1/2 turn.

## **CLEANING AND ADJUSTING THE TOOL BLOCK SLIDE**

Loosen tool module adjustment screws and use a 3/32" wrench to remove the star wheel block screws.

Remove the tool module slide and unscrew the feed screw.

Clean and lubricate the male and female slide surfaces. Clean and lubricate the feed screw.

Reinstall the feed screw into the tool module slide then reinstall the tool module slide.

Install the star wheel block screws and tighten.

Move the tool bit holder to the top of the tool module. Install the 3/32" wrench into the top adjustment screw. Turn it in until it touches off. Tighten the top adjustment screw and turn the star wheel counter-clockwise using the feed sprocket driver. The tension should be a light-firm pressure.

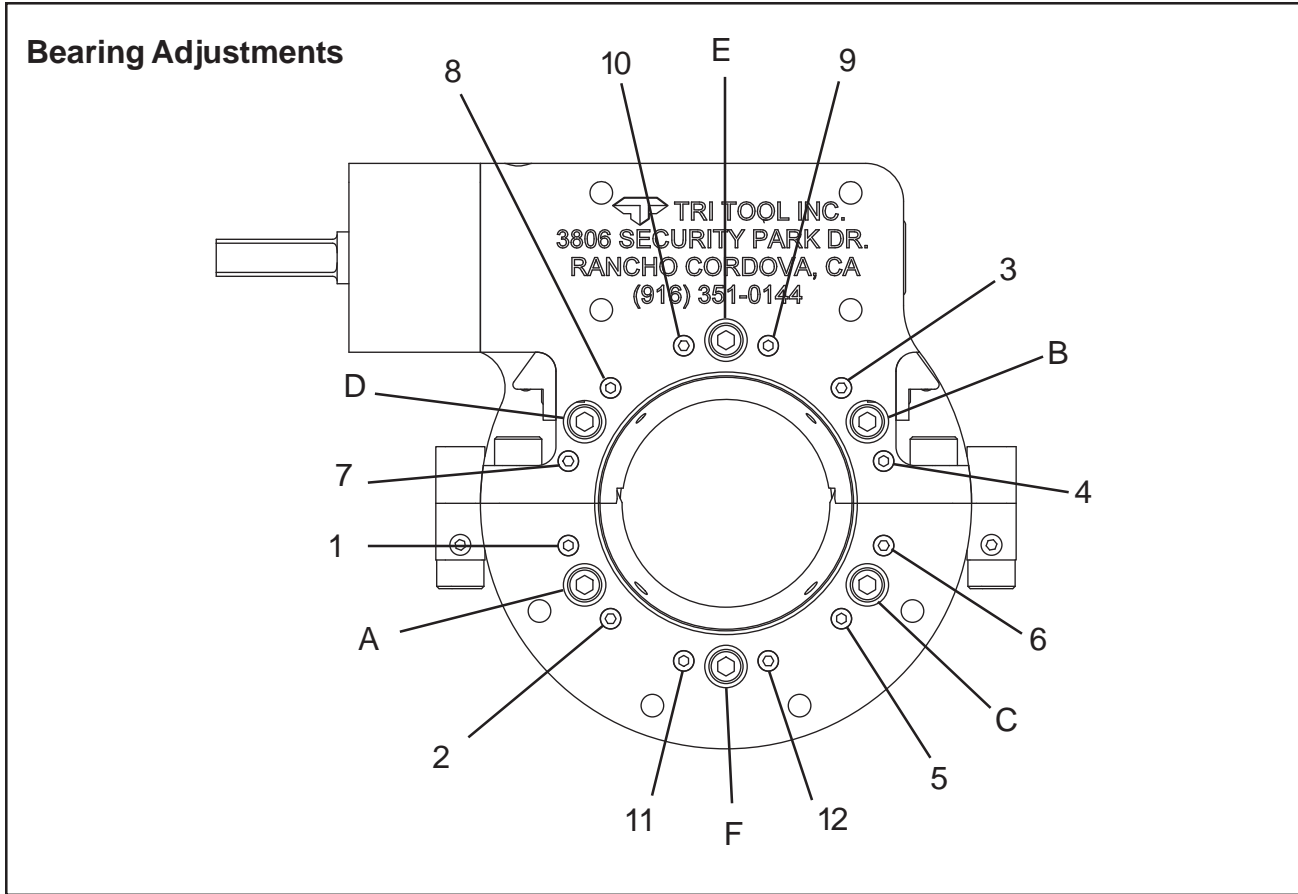

Continue to lower the tool bit slide and install the 3/32" wrench into the lower adjustment screw. Turn it until it touches off. Tighten the lower adjustment screw when the tool bit holder is being turned down to its lower position.

Turn the star wheel clockwise to retract the tool bit holder to the top position. The feed pressure of the feed screw should have a light-firm pressure resistance and remain the same from the bottom to the top of the tool module block.

## ADJUSTING THE MAIN BEARING

Loosen all main bearing locking screws one (1) full turn with the 7/64" wrench. The locking screws are labeled A through F. Reference the figure at end of this section.

Back off the main bearing adjustment screws half a turn with the 5/64" wrench. The main bearing adjustment screws are labeled 1 through 12. Reference the figure at the end of this section.

Start at the two (2) main bearing adjustment screws, 1 and 2. Lower adjustment screws 1 and 2 until they touch, then back them off an eighth of a turn. Repeat this for screws 3 and 4, 5 and 6, 7 and 8, 9 and 10, and 11 and 12, reference the figure at end of

this section. Turn the 1/4" square drive with the ratchet and make sure there are no tight areas in the main bearing. It should turn without any resistance. If light spots of resistance occur then repeat the above procedure.

Tighten all main bearing locking screws, starting with A and going through to F.

Recheck the bearing adjustment using the 1/4" square drive. It should be a little looser.

## STORAGE

### GENERAL STORAGE

Thoroughly clean the tool by removing all chips and debris.

Remove any tool bits with the 9/64" hex wrench and store them appropriately in their container.

Do a complete visual inspection of the tool, checking for loose, worn, or damaged components.

Lubricate and spray with a rust preventative prior to storage.

### LONG TERM STORAGE (30+ DAYS)

For long term storage the general storage procedures should be followed. In addition, lubricate the air motor.

Lubricating the Air Motor:

Remove the air quick disconnect and spray it with a lightweight oil.

Squirt oil into the male quick disconnect.

Reconnect the air line and turn on the air motor for 1 or 2 seconds to coat the internal components.

## CUTTING SPEEDS AND FEEDS

Use 200 surface inches per minute (5080 surface millimeters per minute) for:

Stainless steels in general when no coolant is allowed, all heavy-wall tube and some chrome/molybdenum steels.

Use 250 surface inches per minute (6350 surface millimeters per minute) for:

Mild steels and some thin-wall stainless steels when coolants are permitted and applied.

Use 300 surface inches per minute (7620 surface millimeters per minute) for:

Aluminum and some thin-wall mild steel and tube with coolants.

# COLLETS

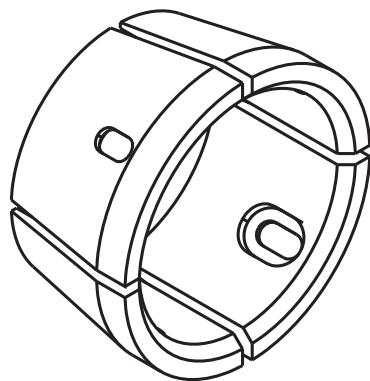

Pipe Size	DIA in Decimal	DIA in Metric	Collet P/N
1/8"	.405"	10.3 mm	30-2891
1/4"	.540"	13.7 mm	30-2892
3/8"	.675"	17.1 mm	30-2893
	.681"	17.3 mm	30-2982
1/2"	.840"	21.3 mm	30-2894
	.854"	21.7 mm	30-2983
3/4"	1.050"	26.7 mm	30-2895
	1.070"	27.2 mm	30-2984
1"	1.315"	33.4 mm	30-2896
601SBCM			

Pipe Size	DIA in Decimal	DIA in Metric	Collet P/N
1"	1.315"	33.40 mm	<b>30-2897*</b>
	1.440"	36.58 mm	30-3218
1 1/4"	1.660"	42.16 mm	30-2898
1 1/2"	1.900"	48.26 mm	<b>30-2899*</b>
2"	2.375"	60.33 mm	<b>30-2900*</b>
602SBCM			

Pipe Size	DIA in Decimal	DIA in Metric	Collet P/N
	1.500"	38.1 mm	30-3136
1 1/4"	1.660"	42.2 mm	30-3161
1 1/2"	1.900"	48.3 mm	30-3162
	1.920"	48.8 mm	30-3135
	2.000"	50.8 mm	30-3134
2"	2.375"	60.3 mm	30-2948
	2.480"	63.0 mm	30-2947
	2.680"	68.1 mm	30-3133
2 1/2"	2.875"	73.0 mm	30-3132
	3.000"	76.2 mm	30-2939
603SBCM			

# TOOL BITS

## 601SBCM STANDARD TOOL BITS

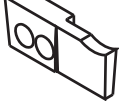
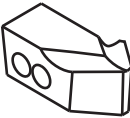
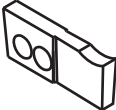
Sever Lead		99-5941	
Double Bevel Use with 99-5941	37 1/2°	99-5942	
Sever Trail Use with 99-5941		99-5943	

## 601SBCM ACCESSORY TOOL BITS

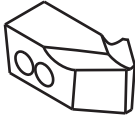
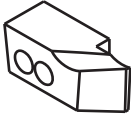
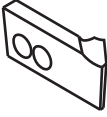
Double Bevel Use with 99-5941	42 1/2° 45° 47 1/2°	99-6003 99-7008 99-6004	
L.H. Single Bevel Use with 99-5941	42 1/2° 45° 47 1/2°	99-5999 99-7010 99-6000	
R.H. Single Bevel Use with 99-5941	33 1/2° 37 1/2° 42 1/2° 45° 47 1/2°	99-6337C4 99-5990 99-6001 99-7009 99-6002	

**601SBCM ACCESSORY TOOL BITS Continued**

Socket Weld  
Inside

99-6340

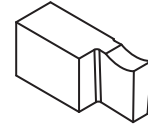

Socket Weld  
Outside

99-6341

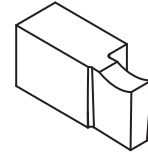

R.H. 'J' Bevel  
Used with 99-5941

30°

99-6338C4

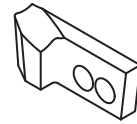

Sever Traill  
Use with 99-5941

99-6357

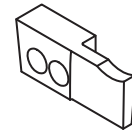

Note: A 'Right Hand Bevel' is on the same side of the cut as the 601SBCM.  
A 'Left Hand Bevel' is on the opposite side of the cut from the 601SBCM.

**602SBCM STANDARD TOOL BITS**

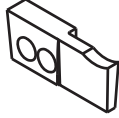
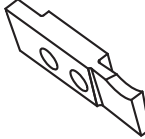
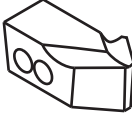
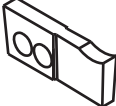
Sever Lead		99-5941	
Sever Lead		99-7140 (1" Sch 80)	
Double Bevel Use with 99-5941	37 1/2°	99-5942	
Sever Trail Use with 99-5941		99-5943	

**602SBCM ACCESSORY TOOL BITS**

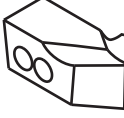
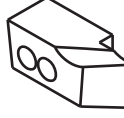

Double Bevel Use with 99-5941	42 1/2°	99-6003	
	45°	99-7008	
	47 1/2°	99-6004	
L.H. Single Bevel Use with 99-5941	42 1/2°	99-5999	
	45°	99-7010	
	47 1/2°	99-6000	

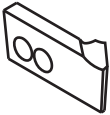
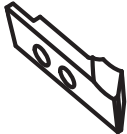
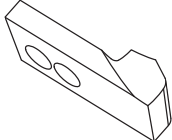
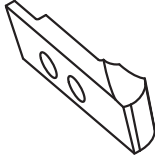
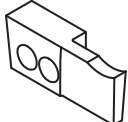
602SBCM ACCESSORY TOOL BITS Continued

R.H. Single Bevel	33 1/2°	99-6337C4	
Use with 99-5941	37 1/2°	99-5990	
	42 1/2°	99-6001	
	45°	99-7009	
	47 1/2°	99-6002	
R.H. Single Bevel	42 1/2°	99-7141 (1" Sch 80)	
Use with 99-7140			
R.H. 'J' Bevel	30°	99-6338C4	
Used with 99-5941			
R.H. 'J' Bevel	27 1/2°	99-7074 (1" Sch 80)	
Use with 99-7140			
Sever Traill		99-6357	
Use with 99-5941			

Note: A 'Right Hand Bevel' is on the same side of the cut as the 602SBCM.  
 A 'Left Hand Bevel' is on the opposite side of the cut from the 602SBCM.

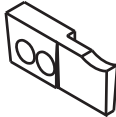
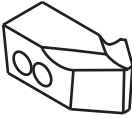
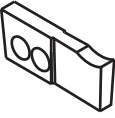
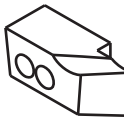
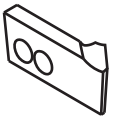
**603SBCM STANDARD TOOL BITS**

Sever Lead		99-5941	
Double Bevel	37 1/2°	99-5942	
Use with 99-5941	42 1/2°	99-6003	
	47 1/2°	99-6004	
Sever Trail		99-5943	
Use with 99-5941			
L.H. Single Bevel	42 1/2°	99-5999	
Use with 99-5941	47 1/2°	99-6000	
R.H. Single Bevel	37 1/2°	99-5990	
Use with 99-5941	42 1/2°	99-6001	
	47 1/2°	99-6002	
Socket Weld Inside		99-5997	
Socket Weld Outside		99-5998	

Note: A 'Right Hand Bevel' is on the same side of the cut as the 603SBCM.  
 A 'Left Hand Bevel' is on the opposite side of the cut from the 603SBCM.

## TROUBLE SHOOTING

**Problem: The Tool Bit Chatters**

The tool bit is loose or overextended.  
The tool bit is damaged.  
The tool holder is too loose in the slides.  
The cutting speed is too fast.  
The clamping pads are loose on the pipe or tube.  
Cutting fluid is required.  
The main bearing pre-load is loose.

**Problem: There is excessive Tool Bit wear**

The pipe or tube material is too hard or abrasive.  
The cutting speed is too fast.  
Cutting fluid is required.  
A dull Tool Bit is causing surface hardening conditions (Stainless pipe or tubing).  
There is scale or other foreign matter on the pipe or tube, which is dulling the tool bit at the start of the cut.  
The tool bit is incorrect for the material being cut.

**Problem: The surface finish is rough**

The tool bit is dull, chipped, etc.  
Metal build-up on the cutting edge of the tool bit is creating a false cutting edge.  
Cutting fluid is required.

**Problem: The tool holder is not feeding**

The feed pin is broken or out of position.  
The feed sprocket shear pin is broken.  
The feed screw is stripped.  
The feed nut is stripped.  
The slide rails are too tight.

**Problem: There is a loss of air power**

The air supply pressure is too low.  
The air filter is plugged.  
The air line size is insufficient.  
The air line is too long.

**Problem: There is a loss of hydraulic power**

The hydraulic supply pressure is too low.  
The hydraulic filter is plugged.  
The hydraulic line size is insufficient.  
The hydraulic line is too long.

**Problem: The tool bit will not reach the work**

Incorrect tool blocks are installed for the size of the pipe or tube being worked on.  
Incorrect tool bit is installed.

**Problem: The hydraulic motor will not start**

The hydraulic power supply is shut off.  
The hydraulic motor is damaged and will not run free.

# ACCESSORIES

The following accessory is available for use with the Model 600SBCM series from TRI TOOL INC.

Item No.	Part No.	Description	Qty
1.	82-0178	AUTO-DISENGAGE TRIPPER MODULE	1

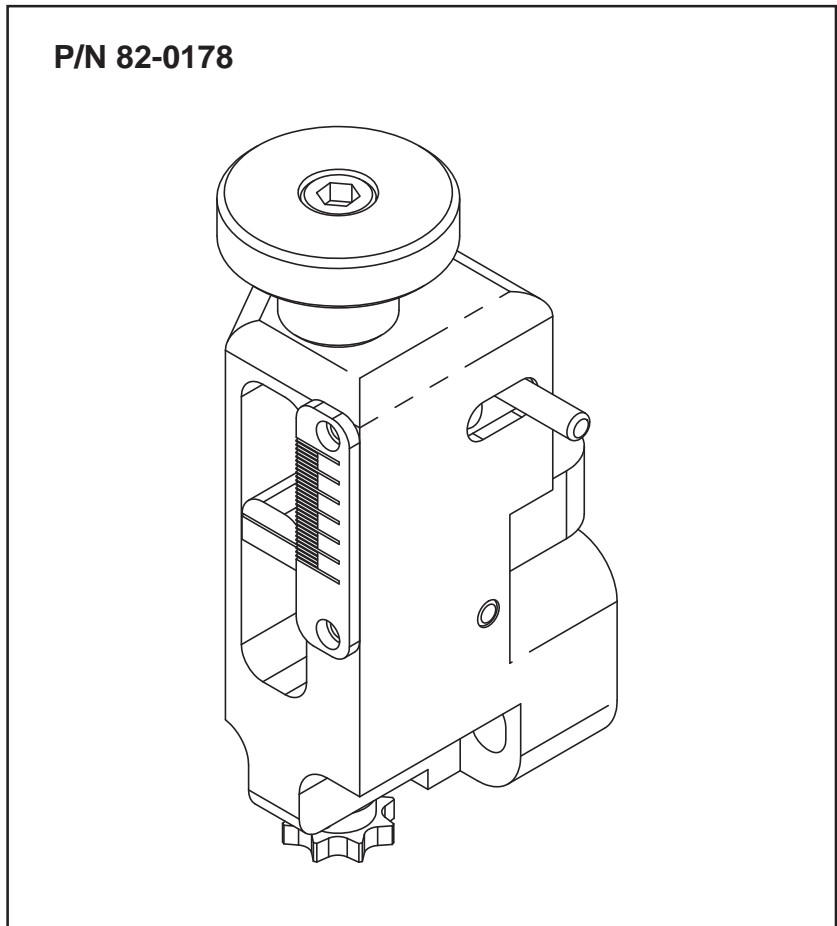

# TRI TOOL INC.

---

The following accessory is available for use with the Model 601SBCM from TRI TOOL INC.

Item No.	Part No.	Description	Qty
1.	49-0590	SOCKET WELD REMOVAL TOOL HOLDER ASSY	1

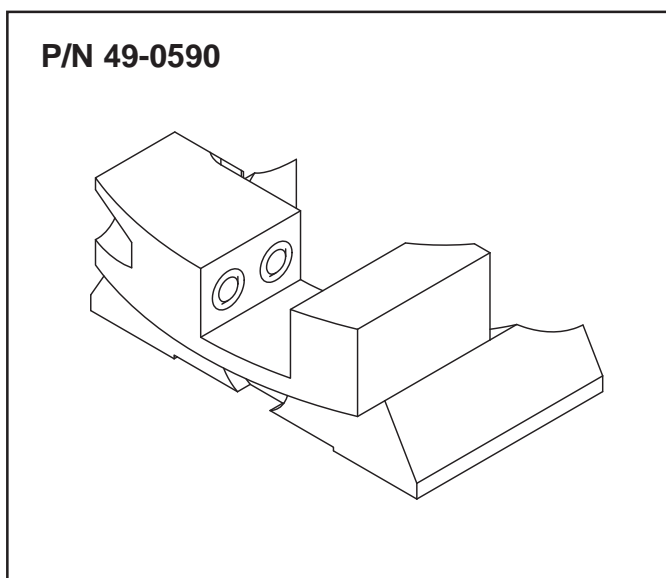

ILLUSTRATED PARTS BREAKDOWN

MODEL 600SBCM CLAMSHELL

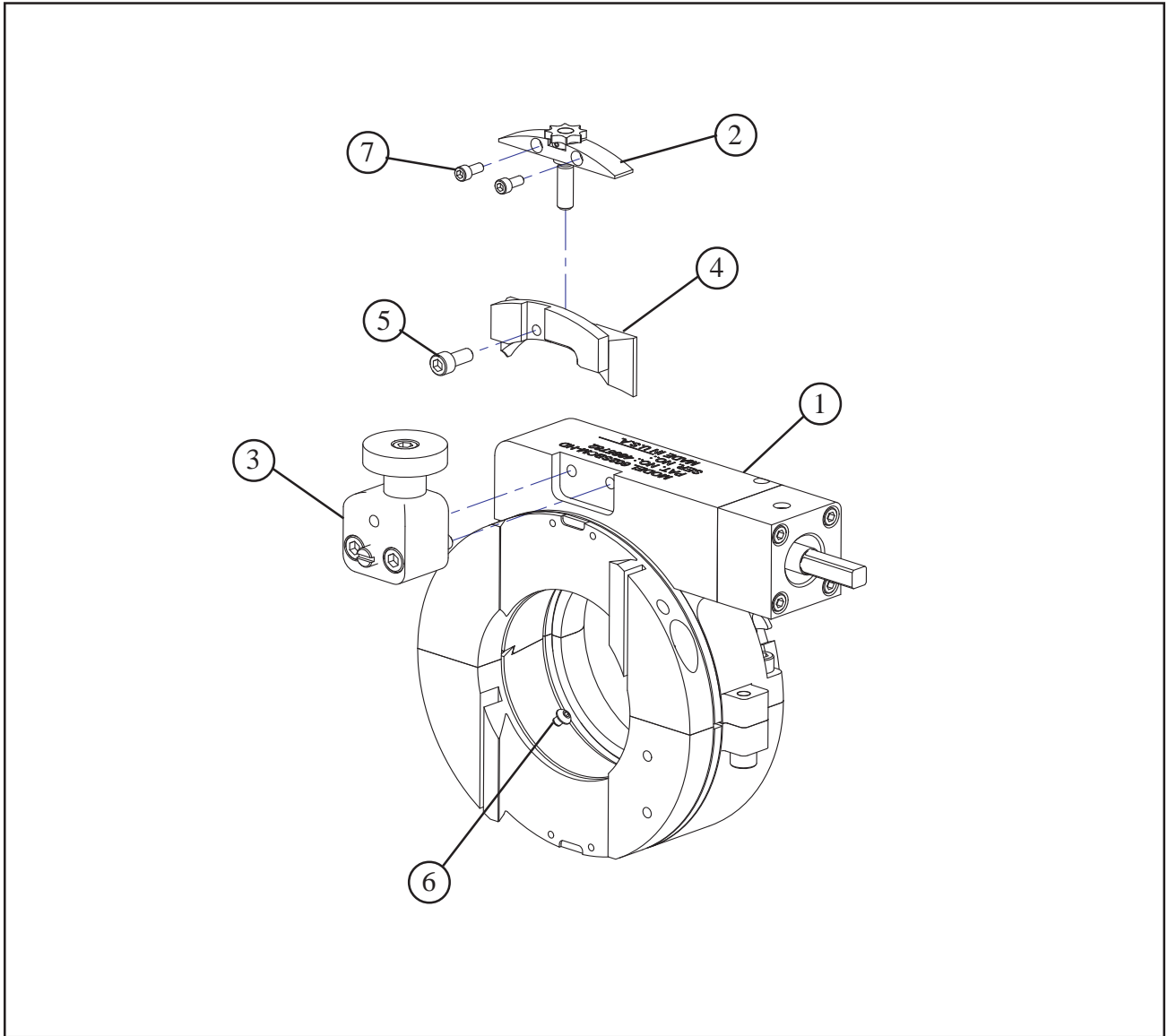

**TRI TOOL INC.**

---

## Parts List, 601SBCM Clamshell (P/N 01-1814)

<b>Item No.</b>	<b>Part No.</b>	<b>Description</b>	<b>Qty</b>
1.	02-2417	MODEL 601SBCM SUB-ASSEMBLY	1
2.	38-0169	SPROCKET ASSEMBLY, FEED	2
3.	47-1521	BLOCK ASSEMBLY, TRIPPER	1
4.	49-0410	HOLDER, TOOL	2
5.	33-2647	SCREW, CAP, #8-32 X 3/8", SST	2
6.	33-2531	SCREW, BUTTON, #4-40 X 3/16"	4
7.	33-2644	SCREW, CAP, #4-40 X 1/4", SST	4

## Parts List, 602SBCM Clamshell (P/N 01-1819)

<b>Item No.</b>	<b>Part No.</b>	<b>Description</b>	<b>Qty</b>
1.	02-2422	602SBCM SUB - ASSEMBLY	1
2.	38-0170	SPROCKET ASSY., FEED	2
3.	47-1521	BLOCK ASSEMBLY, TRIPPER	1
4.	49-0413	HOLDER, TOOL	2
5.	33-2647	SCREW, CAP #8-32 x 3/8", SST	2
6.	33-2531	SCREW, BUTTON #4-40 X 3/16"	4
7.	33-2644	SCREW,CAP,#4-40 X 1/4", SST	4

## Parts List, 603SBCM Clamshell (P/N 01-1818)

<b>Item No.</b>	<b>Part No.</b>	<b>Description</b>	<b>Qty</b>
1.	02-2421	603SBCM SUB - ASSY.	1
2.	38-0170	SPROCKET ASSY., FEED	2
3.	47-1521	TRIPPER BLOCK ASSY.	1
4.	49-0433	HOLDER, TOOL	2
5.	33-2647	SCREW, CAP #8-32 x 3/8"LG, SST	2
6.	33-2531	SCREW, BUTTON #4-40 x 3/16"LG	4
7.	33-2644	SCREW,CAP,#4-40 X 1/4", SST	4

601SBCM SUB-ASSEMBLY (P/N 02-2417)

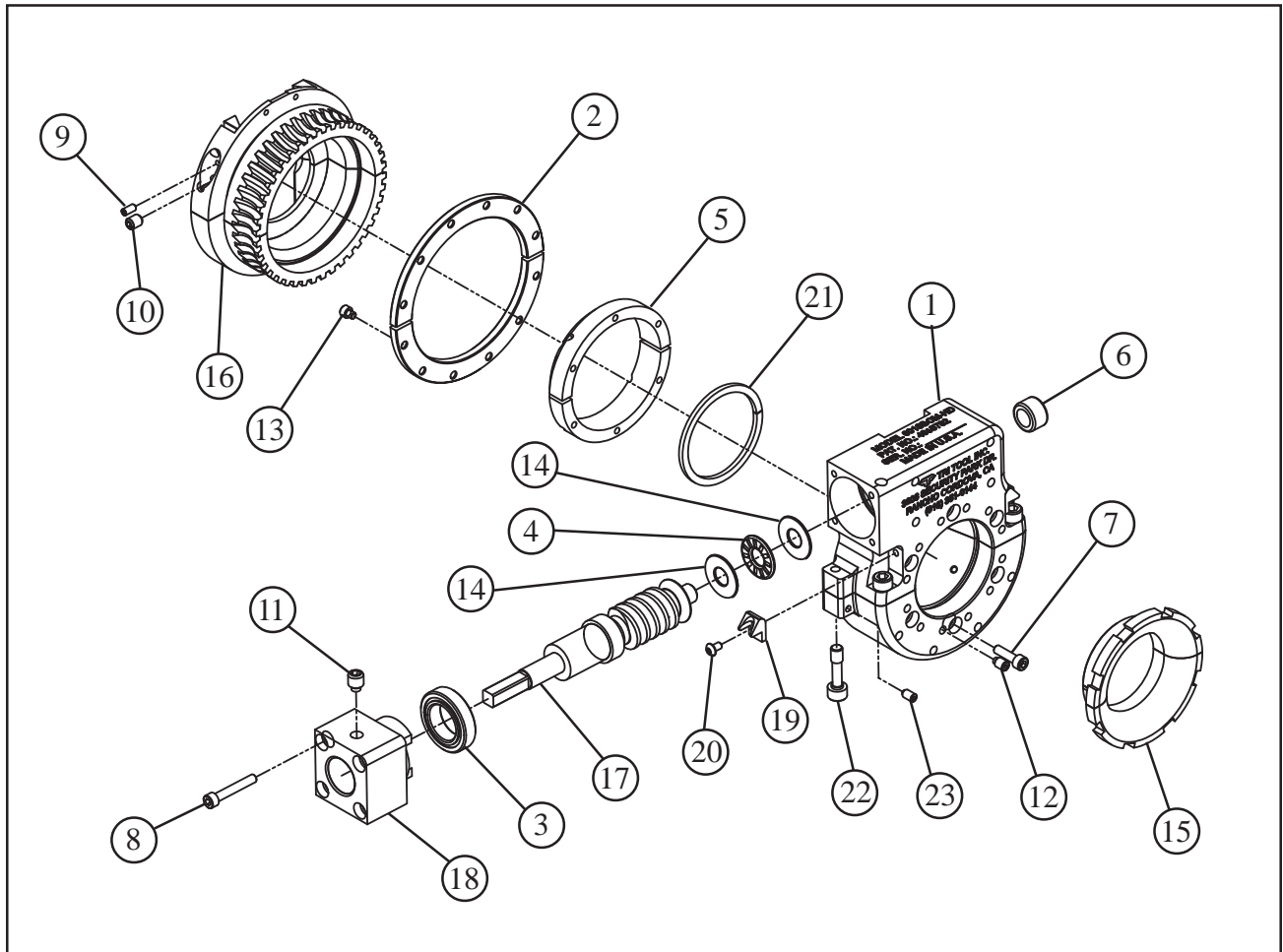

Parts List, 601SBCM Sub-Assembly (P/N 02-2417)

Item No.	Part No.	Description	Qty
1.	19-1081	HOUSING, MAIN	1
2.	24-1793	PLATE, THRUST	1
3.	29-0064	BRG, BALL, 5/8" X 1 1/16" X 9/32"	1
4.	29-0190	BRG, THRST, 5/16" X 3/4" X 5/64"	1
5.	29-0402	BEARING, MAIN	1
6.	29-0404	BEARING, NEEDLE, .3125" ID	1
7.	33-2645	SCREW, CAP, #6-32 X 1/2", SST	6
8.	33-2658	SCREW, CAP, #6-32 X 3/4", SST	4
9.	33-0450	SCREW, SET, #4-40 X 1/4", CUP PT	2
10.	33-0488	SCREW, SET, #10-24 X 1/4", CUP PT	4

**TRI TOOL INC.**

---

## Parts List, 601SBCM Sub-Assembly (P/N 02-2417) Continued

<b>Item No.</b>	<b>Part No.</b>	<b>Description</b>	<b>Qty</b>
11.	33-0903	SCREW, SET, 1/4-20 X 5/16", HALF DOG	1
12.	33-1605	SCREW, SET, #8-32 X 1/4", HALF DOG	12
13.	33-2266	SCREW, CAP, #4-40 X 1/8", SST	12
14.	34-0202	WASHER, THRST, 5/16" X 3/4"	2
15.	35-0589	NUT, CLAMP	1
16.	39-0913	GEAR, MAIN	1
17.	39-0914	GEAR, WORM, RH, 16 DP, 1 T, .625 PD	1
18.	43-0741	COVER, WORM	1
19.	48-2047	BLOCK, RETAINING, SCREW	2
20.	33-2531	SCREW, BUTTON, #4-40 X 3/16"	2
21.	28-0367	SEAL, FELT, 3/32" X 1/8"	5.12"
22.	33-2501	SCREW, SPLITLINE	2
23.	33-2502	SCREW, SET, #6-32 X 1/4", H DOG	2

602SBCM SUB-ASSEMBLY (P/N 02-2422)

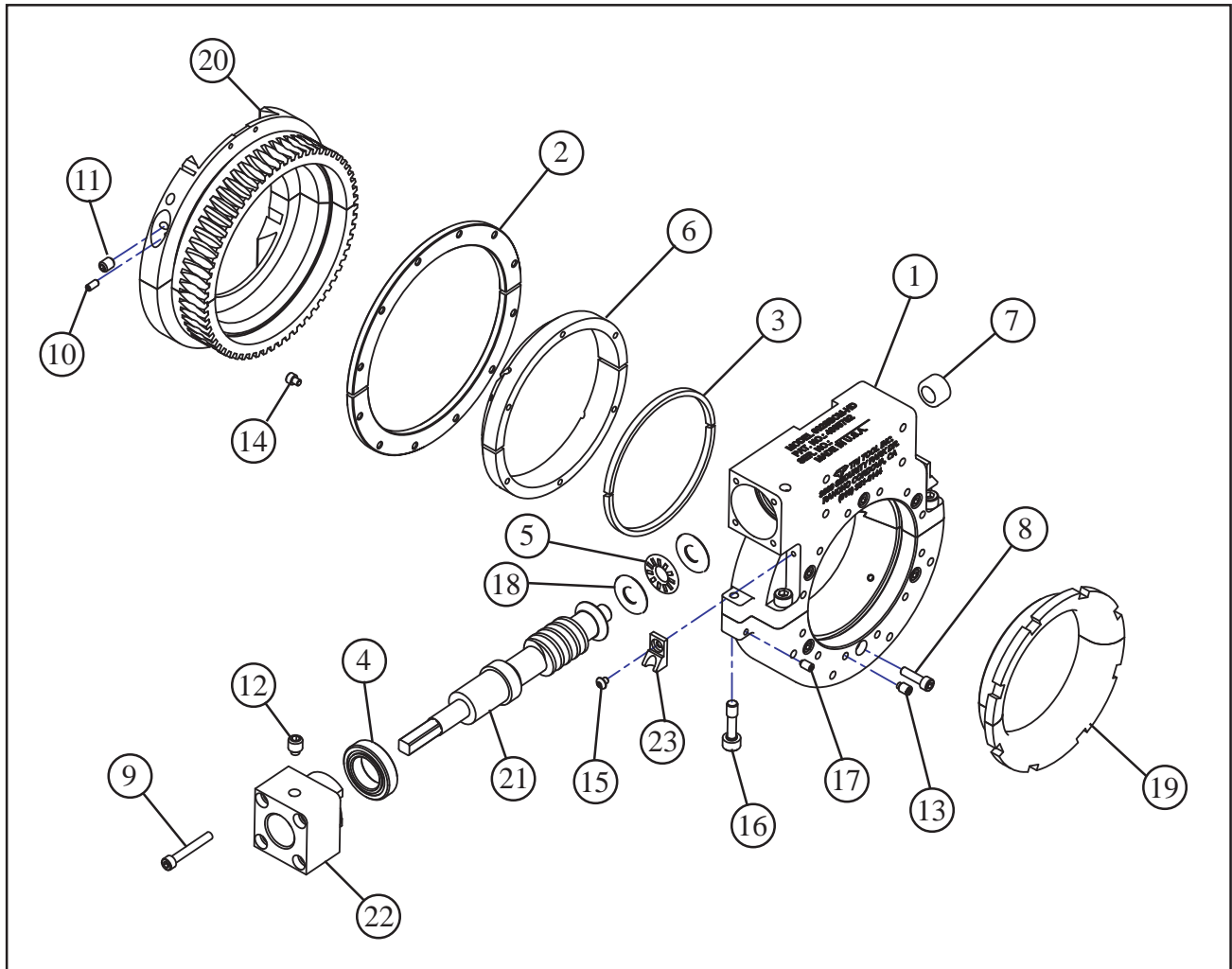

Parts List, 602SBCM Sub-Assembly (P/N 02-2422)

Item No.	Part No.	Description	Qty
1.	19-1087	HOUSING, MAIN, HD	1
2.	24-2369	PLATE, THRUST, HD	1
3.	28-0367	SEAL, FELT, 3/32" X 1/8" X BULK	8.75"
4.	29-0064	BEARING, BALL, 5/8" X 1 1/16" X 9/32"	1
5.	29-0190	BEARING, THRUST, 5/16" X 3/4" X 5/64"	1
6.	29-0476	BEARING, MAIN, HD	1
7.	29-0404	BEARING, NEEDLE	1
8.	33-2645	SCREW, CAP, #6 - 32 X 1/2", SST	6
9.	33-2646	SCREW, CAP, #6 - 32 X 1", SST	4

**TRI TOOL INC.**

---

## Parts List, 602SBCM Sub-Assembly (P/N 02-2422) Continued

<b>Item No.</b>	<b>Part No.</b>	<b>Description</b>	<b>Qty</b>
10.	33-0450	SCREW, SET, #4 - 40 X 1/4", CUP PT.	2
11.	33-0488	SCREW, SET, #10 - 24 X 1/4", CUP PT.	4
12.	33-0903	SCREW, SET, 1/4 - 20 X 5/16", HALF DOG	1
13.	33-1605	SCREW, SET, #8 - 32 X 1/4", HALF DOG	12
14.	33-2266	SCREW, CAP, #4 - 40 X 1/8"	12
15.	33-2531	SCREW, BUTTON, #4-40 X 3/16"	2
16.	33-2501	SCREW, SPLITLINE, HD	2
17.	33-2502	SCREW, SET, #6-32 X 1/4" HALF DOG	2
18.	34-0202	WASHER, THRUST	2
19.	35-0592	NUT, CLAMP	1
20.	39-0915	GEAR, MAIN	1
21.	39-0916	GEAR, WORM	1
22.	43-0577	COVER, WORM	1
23.	48-2076	BLOCK, RETAINING	2

603SBCM SUB-ASSEMBLY (P/N 02-2421)

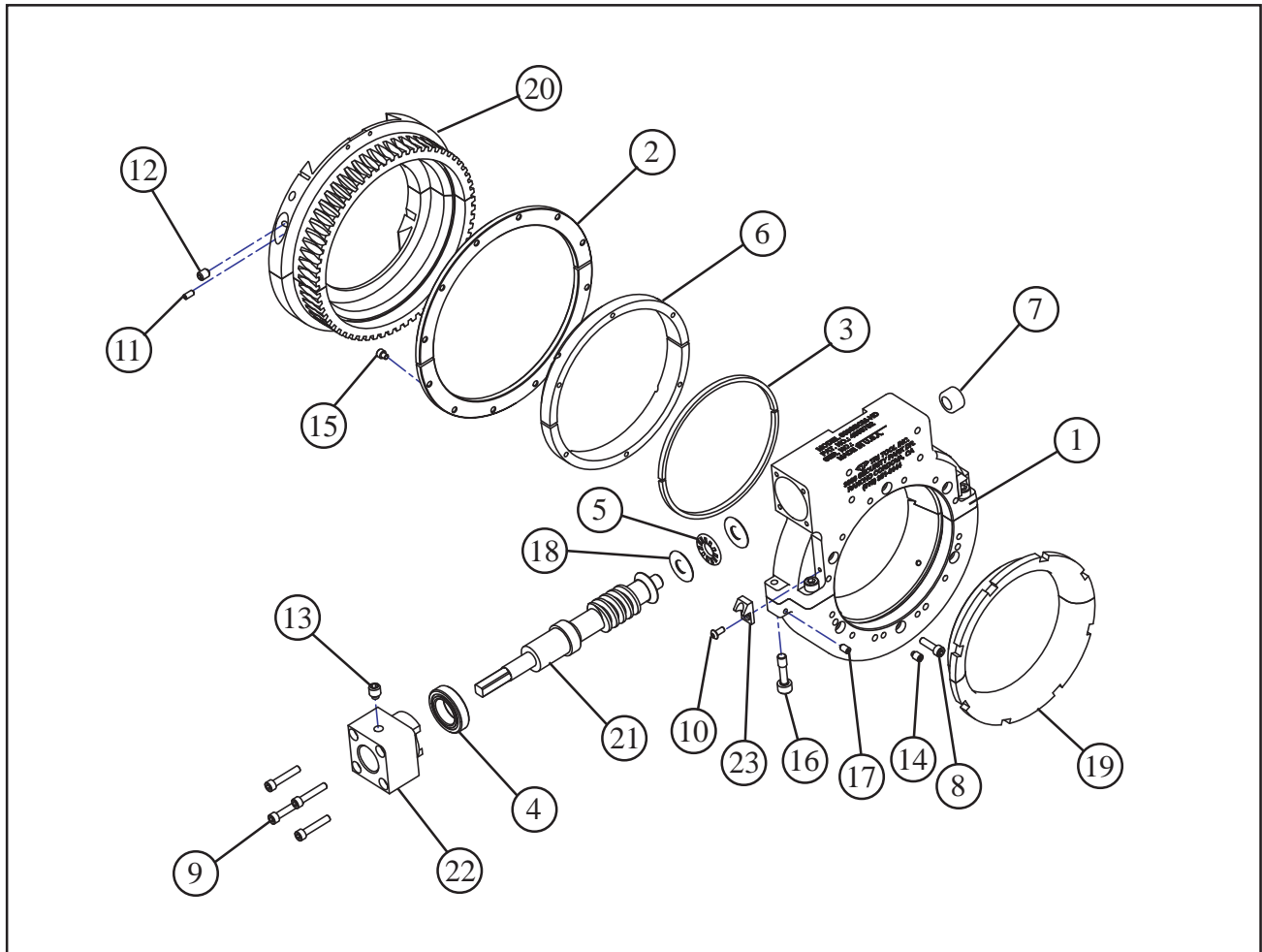

Parts List, 603SBCM Sub-Assembly (P/N 02-2421)

Item No.	Part No.	Description	Qty
1.	19-1086	HOUSING, MAIN,HD	1
2.	24-2368	PLATE, THRUST,HD	1
3.	28-0367	SEAL,FELT,3/32" X 1/8" X BULK	10.80
4.	29-0064	BEARING, BALL, 5/8" X 1 1/16" X 9/32"	1
5.	29-0190	BEARING, THRUST, 5/16" X 3/4" X 5/64"	1
6.	29-0475	BEARING, MAIN	1
7.	29-0404	BEARING, NEEDLE	1
8.	33-2645	SCREW, CAP, #6 - 32 X 1/2", SST	6
9.	33-2646	SCREW, CAP, #6 - 32 X 1", SST	4

**TRI TOOL INC.**

---

## Parts List, 603SBCM Sub-Assembly (P/N 02-2421) Continued

<b>Item No.</b>	<b>Part No.</b>	<b>Description</b>	<b>Qty</b>
10.	33-2489	SCREW,BUTTON,#4-40 X 1/8"	2
11.	33-0450	SCREW, SET, #4 - 40 X 1/4", CUP PT.	2
12.	33-0488	SCREW, SET, #10 - 24 X 1/4", CUP PT.	4
13.	33-0903	SCREW, SET, 1/4 - 20 X 5/16", HALF DOG	1
14.	33-1605	SCREW, SET, #8 - 32 X 1/4", HALF DOG	12
15.	33-2266	SCREW, CAP, #4 - 40 X 1/8"	12
16.	33-2501	SCREW,SPLITLINE,HD	2
17.	33-2502	SCREW,SET,#6-32 X .250, H-DOG	2
18.	34-0202	WASHER, THRUST, 5/16" X 3/4"	2
19.	35-0605	NUT, CLAMP	1
20.	39-0932	GEAR, MAIN	1
21.	39-0916	GEAR, WORM	1
22.	43-0577	COVER, WORM	1
23.	48-2076	BLOCK,RETAINING	2

600SBCM HOUSING, MAIN

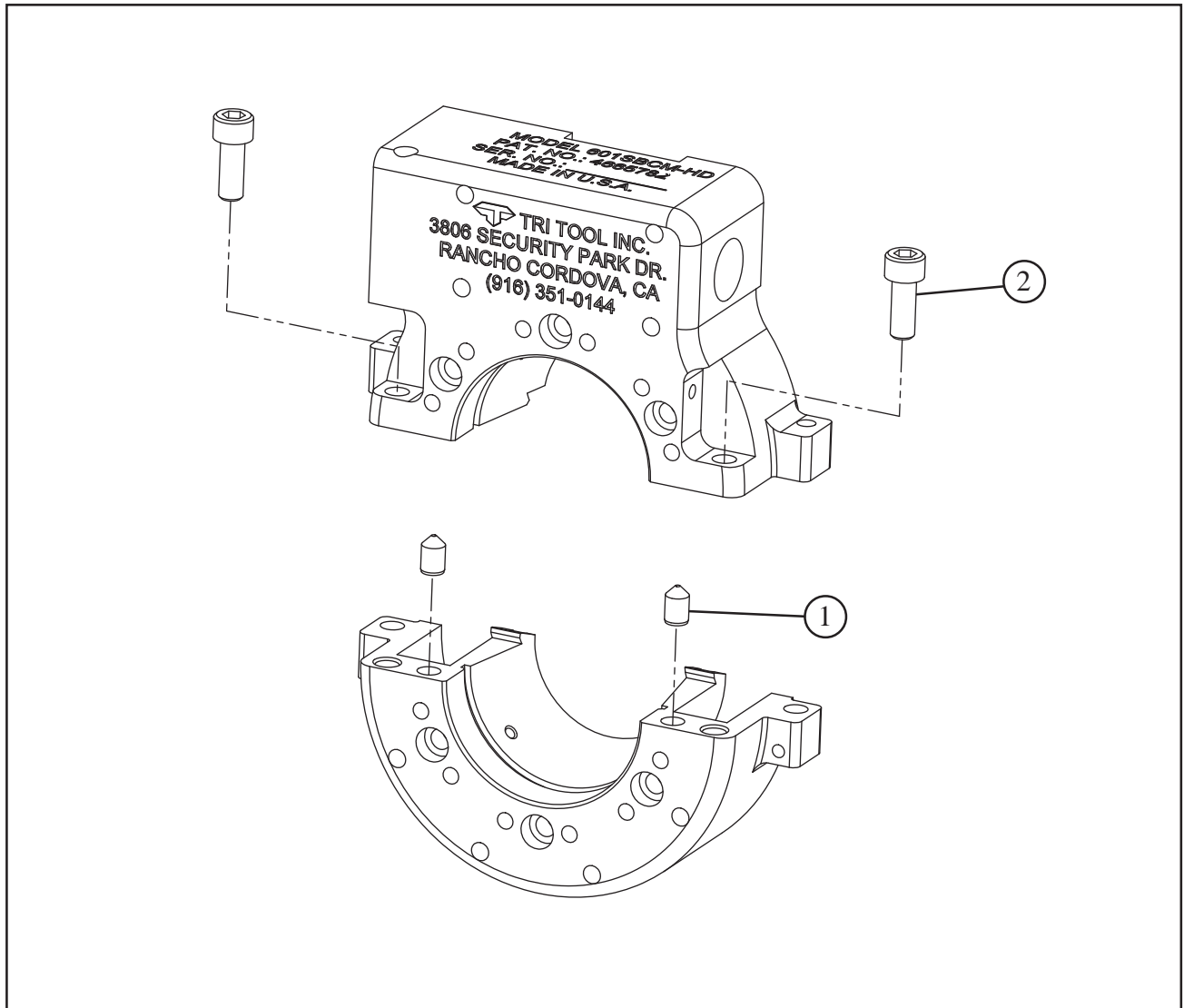

**TRI TOOL INC.**

---

## Parts List, 601SBCM Housing, Main (P/N 19-1081)

<b>Item No.</b>	<b>Part No.</b>	<b>Description</b>	<b>Qty</b>
1.	32-0598	PIN, ALIGN, 3/16" DIA X 5/16"	2
2.	33-2649	SCREW, CAP, #10-24 X 5/8", SST	2

## Parts List, 602SBCM Housing, Main, Heavy Duty (P/N 19-1087)

<b>Item No.</b>	<b>Part No.</b>	<b>Description</b>	<b>Qty</b>
1.	32-0598	PIN, ALIGN, 3/16" DIA X 5/16"	2
2.	33-2649	SCREW,CAP,#10-24 X 5/8", SST	2

## Parts List, 603SBCM Housing, Main (P/N 19-1086)

<b>Item No.</b>	<b>Part No.</b>	<b>Description</b>	<b>Qty</b>
1.	32-0598	PIN, ALIGN, 3/16" DIA X 5/16"	2
2.	33-2649	SCREW, CAP, #10-24 X 5/8", SST	2

600SBCM NUT, CLAMP

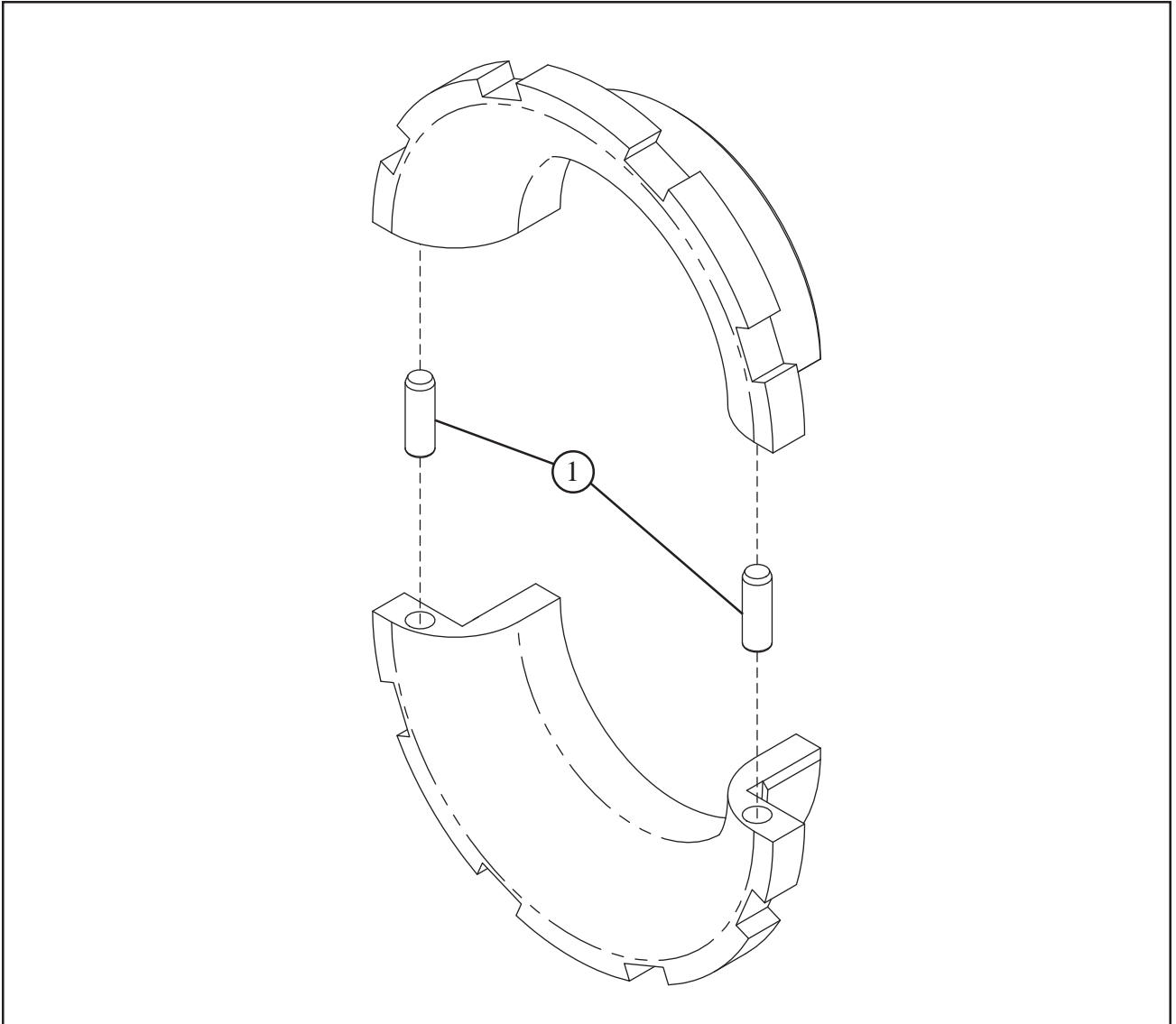

**TRI TOOL INC.**

---

Parts List, 601SBCM Nut, Clamp (P/N 35-0589)

<b>Item No.</b>	<b>Part No.</b>	<b>Description</b>	<b>Qty</b>
1.	32-0220	PIN, DOWEL, 1/8" DIA X 3/8"	2

Parts List, 602SBCM Nut, Clamp (P/N 35-0592)

<b>Item No.</b>	<b>Part No.</b>	<b>Description</b>	<b>Qty</b>
1.	32-0220	PIN, DOWEL, 1/8" DIA X 3/8"	2

Parts List, 603SBCM Nut, Clamp (P/N 35-0605)

<b>Item No.</b>	<b>Part No.</b>	<b>Description</b>	<b>Qty</b>
1.	32-0220	PIN, DOWEL, 1/8" DIA X 3/8"	2

600SBCM GEAR, MAIN

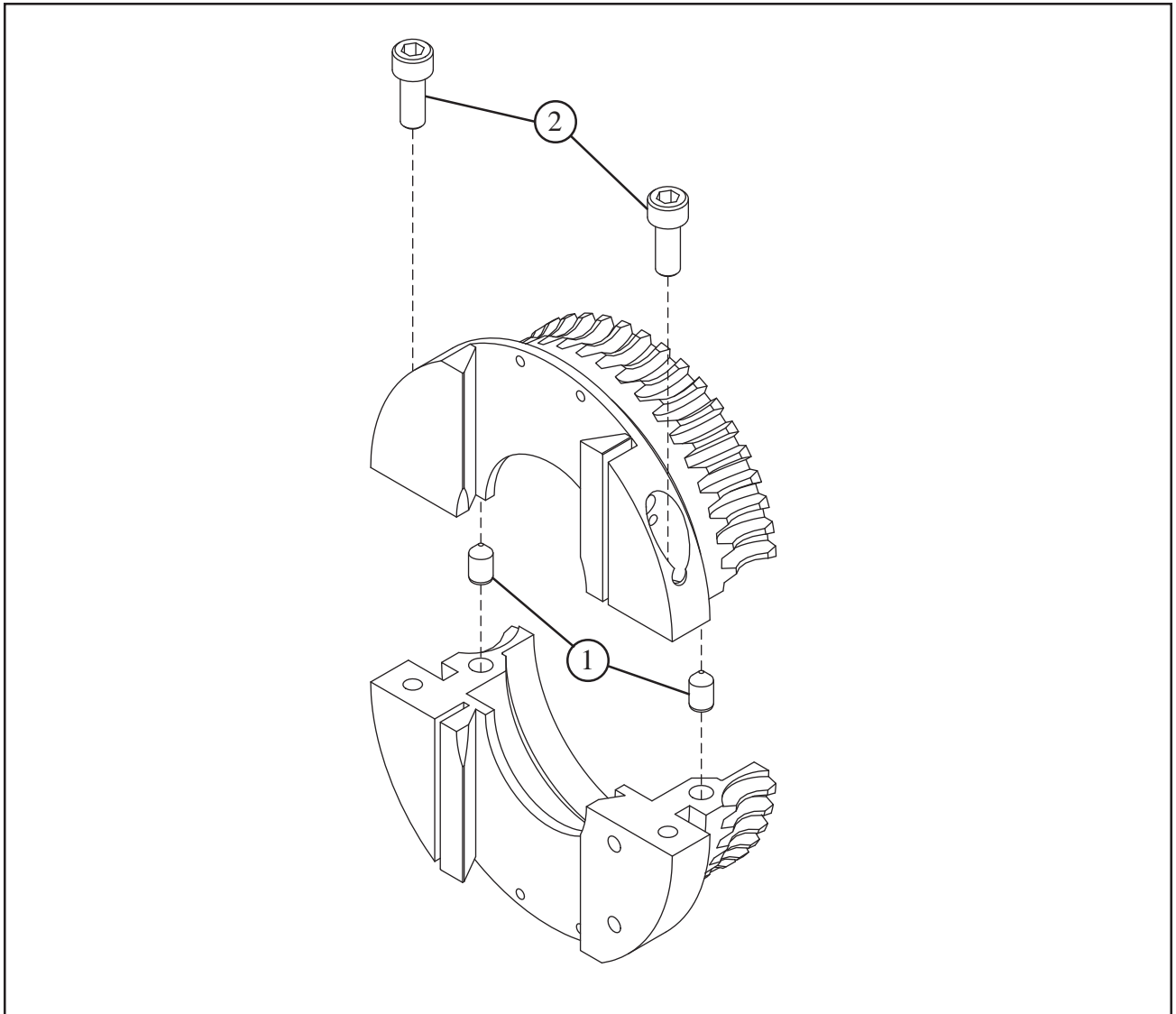

**TRI TOOL INC.**

---

## Parts List, 601SBCM Gear, Main (P/N 39-0913)

<b>Item No.</b>	<b>Part No.</b>	<b>Description</b>	<b>Qty</b>
1.	32-0598	PIN, ALIGN, 3/16" DIA X 5/16"	2
2.	33-2648	SCREW, CAP, #10-24 X 1/2", SST	2

## Parts List, 602SBCM Gear, Main (P/N 39-0915)

<b>Item No.</b>	<b>Part No.</b>	<b>Description</b>	<b>Qty</b>
1.	32-0598	PIN, ALIGN, 3/16" DIA X 5/16"	2
2.	33-2648	SCREW, CAP, #10-24 X 1/2", SST	2

## Parts List, 603SBCM Gear, Main (P/N 39-0932)

<b>Item No.</b>	<b>Part No.</b>	<b>Description</b>	<b>Qty</b>
1.	32-0598	PIN, ALIGN, 3/16" DIA X 5/16"	2
2.	33-2648	SCREW, CAP, #10-24 X 1/2", SST	2

600SBCM BLOCK ASSEMBLY, TRIPPER (P/N 47-1521)

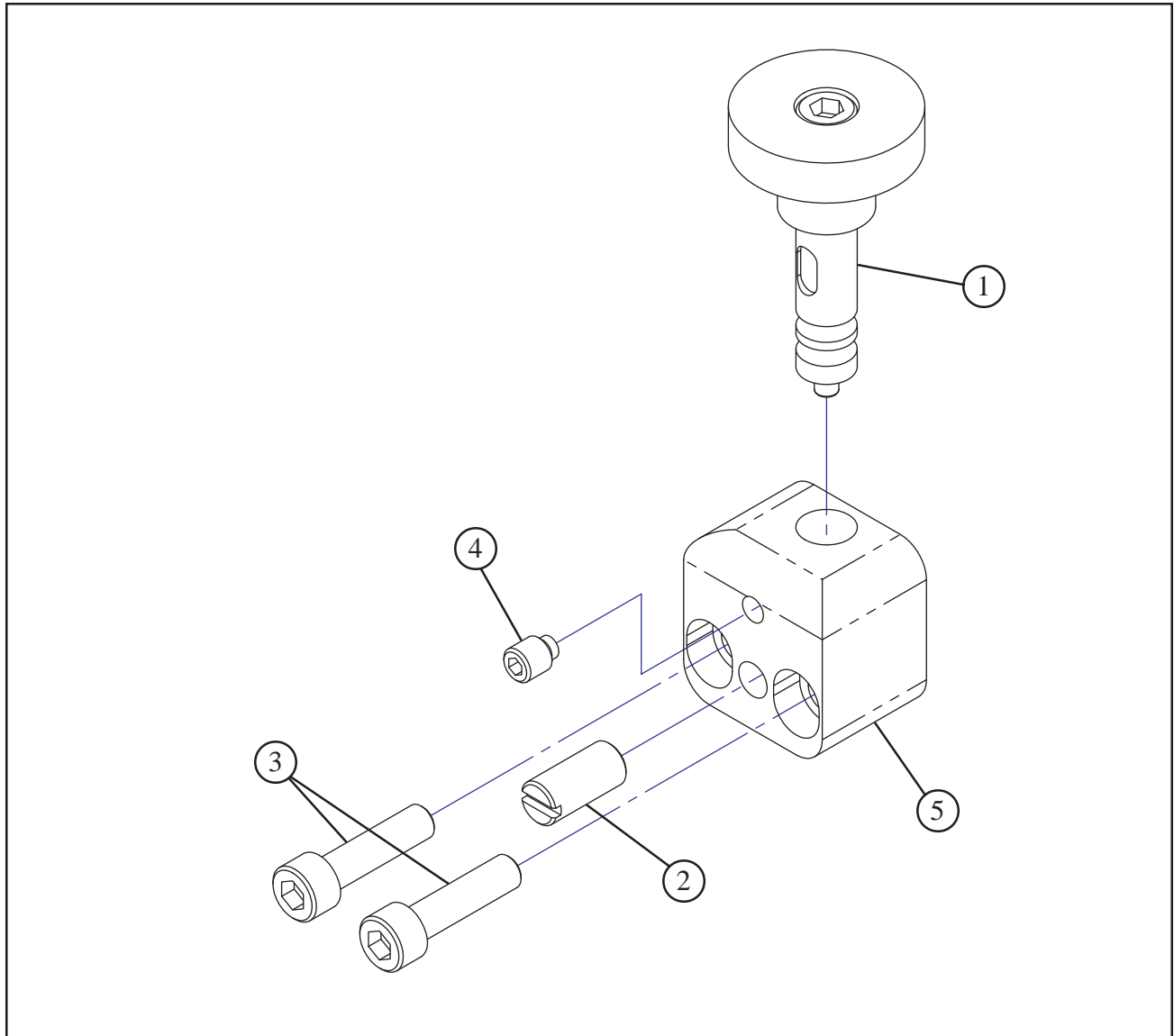

Parts List, 600SBCM Block Assembly, Tripper (P/N 47-1521)

Item No.	Part No.	Description	Qty
1.	14-0097	SHAFT ASSEMBLY, TRIPPER	1
2.	30-0125	PLUNGER, BALL, 1/4-20 X 17/32"	1
3.	33-2650	SCREW, CAP, #10-24 X 3/4", SST	2
4.	33-0954	SCREW, SET, #10-24 X 1/4", HALF DOG	1
5.	48-1322	BLOCK, TRIPPER	1

600SBCM SHAFT ASSEMBLY, TRIPPER (P/N 14-0097)

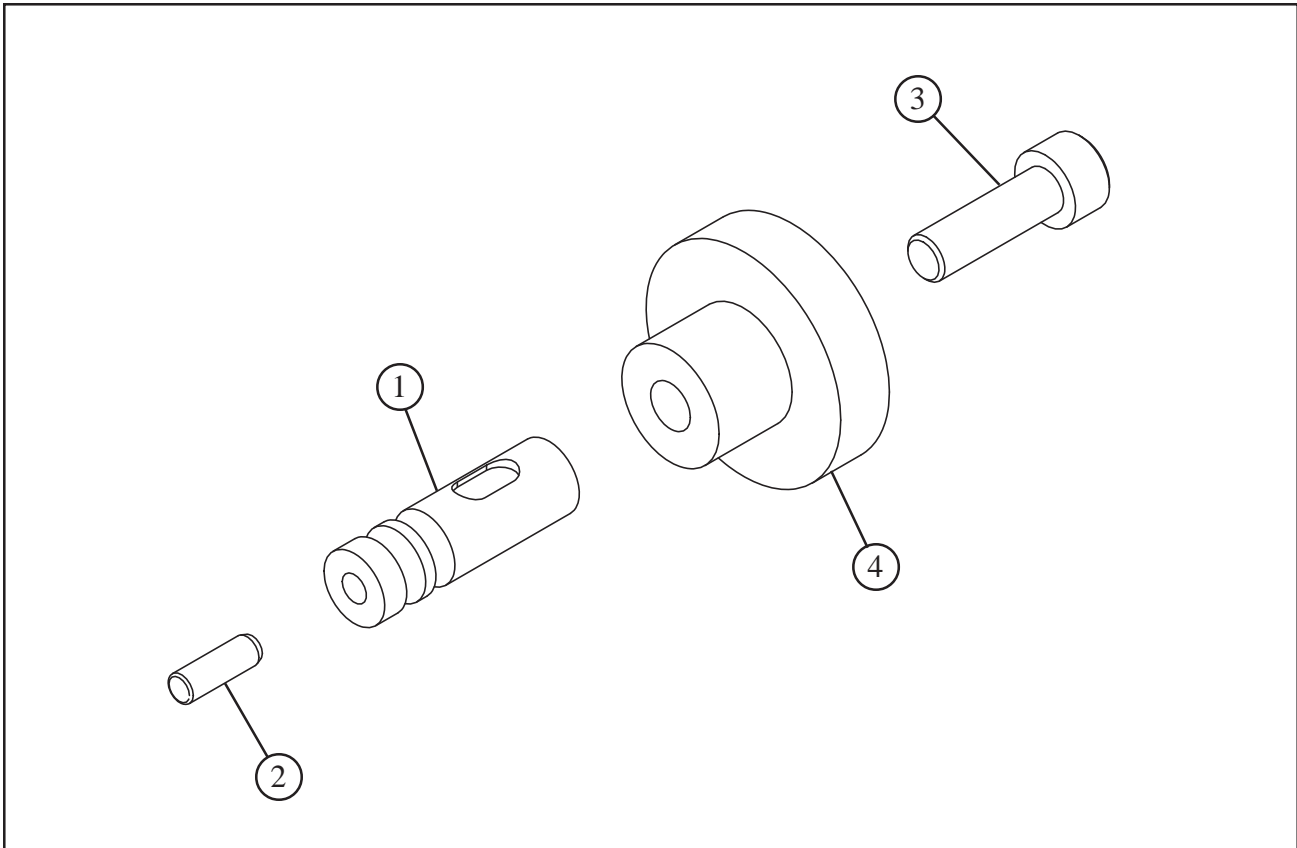

Parts List, 600SBCM Shaft Assembly, Tripper (P/N 14-0097)

Item No.	Part No.	Description	Qty
1.	20-0803	SHAFT, TRIPPER	1
2.	32-0220	PIN, DOWEL, 1/8" DIA X 3/8"	1
3.	33-2649	SCREW, CAP, #10-24 X 5/8", SST	1
4.	42-0217	KNOB	1

600SBCM SHAFT ASSEMBLY, FLEXIBLE H.D. (P/N 14-0091)

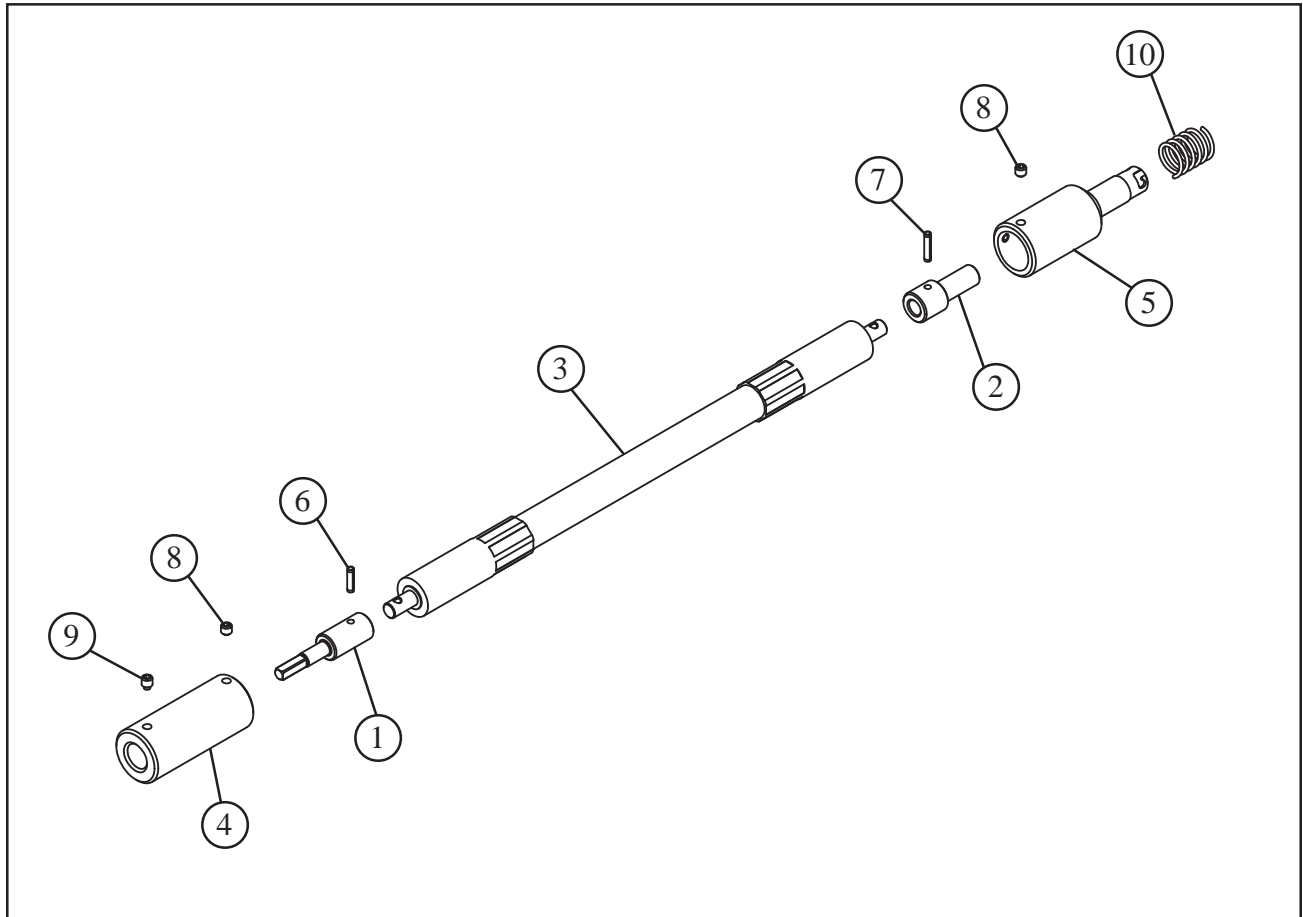

Parts List, 600SBCM Shaft Assembly, Flexible HD (P/N 14-0091)

Item No.	Part No.	Description	Qty
1.	20-0844	SHAFT, DRIVE, FLEX	1
2.	20-0845	SHAFT, ADAPTER, FLEX	1
3.	20-0904	SHAFT, FLEXIBLE, 18" HEAVY DUTY	1
4.	27-0726	ADAPTER, SQUARE, FLEX SHAFT	1
5.	27-0727	ADAPTER, BAYONET, FLEX SHAFT	1
6.	32-0034	PIN, ROLL, 5/32" DIA X 5/8"	1
7.	32-0035	PIN, ROLL, 5/32" DIA X 3/4"	1
8.	33-0498	SCREW, SET, 1/4-20 X 3/16", CUP PT	4
9.	33-0903	SCREW, SET, 1/4-20 X 5/16", HALF DOG	1
10.	40-0143	SPRING, MUSIC WIRE, LC-085K-3	1

**600SBCM MOTOR ASSEMBLY, BAYONET (P/N 57-0269)**

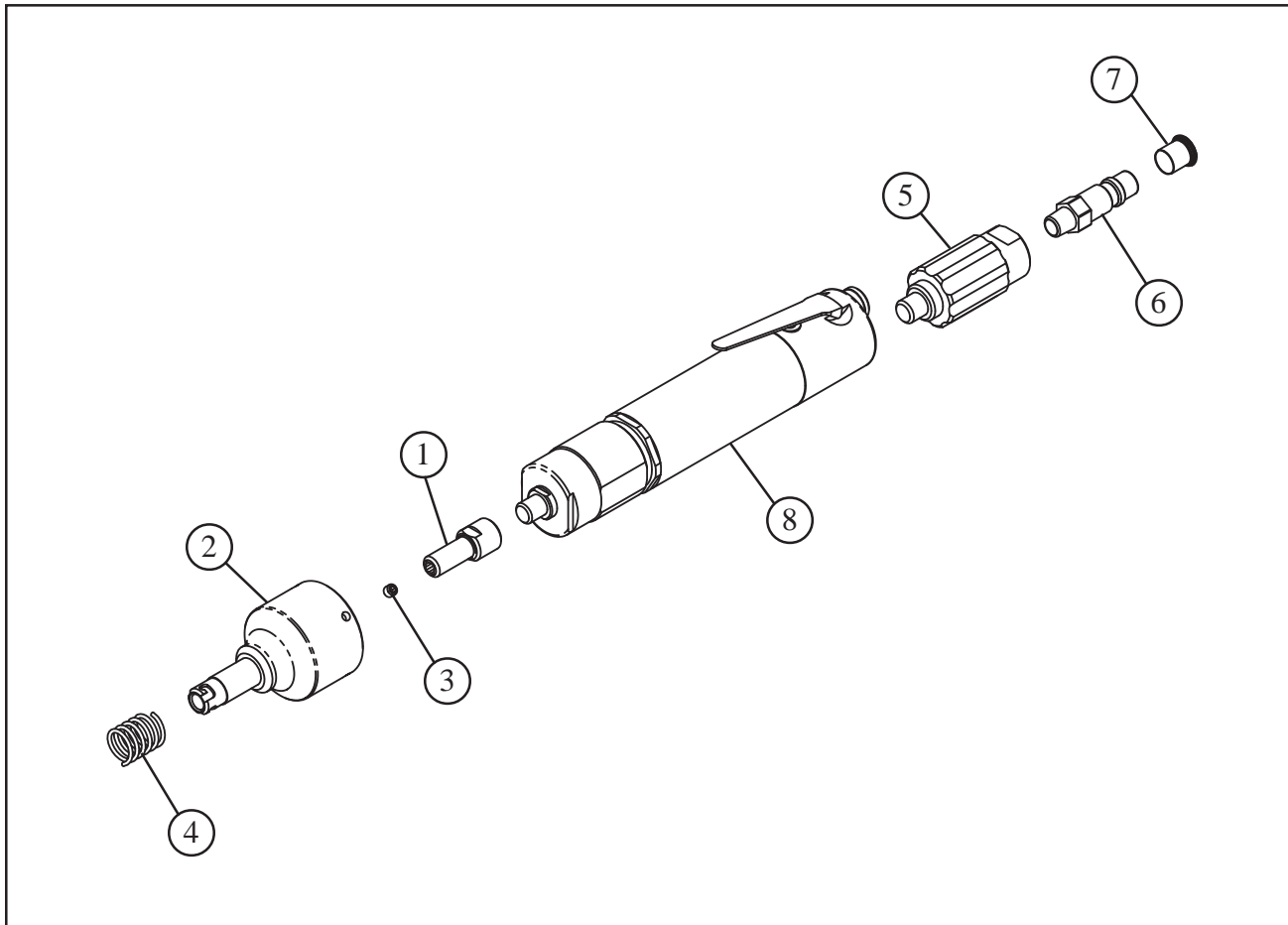

Parts List, 600SBCM Motor Assembly, Bayonet (P/N 57-0269)

Item No.	Part No.	Description	Qty
1.	20-0806	SHAFT, DRIVE	1
2.	27-0703	ADAPTER, BAYONET	1
3.	33-0498	SCREW, SET, 1/4-20 X 3/16", CUP PT	4
4.	40-0143	SPRING, MUSIC WIRE, LC-085K-3	1
5.	53-0045	VALVE, FLOW CONTROL, 1/4" NPT	1
6.	54-0149	COUPLING, MAIL, QD, HOSE TO PIPE	1
7.	54-0201	CAP, YELLOW	1
8.	57-0257	MOTOR, AIR	1

**601SBCM AND 602SBCM  
WHEEL ASSEMBLY, ROLLER CUTTER (P/N 61-0159)**

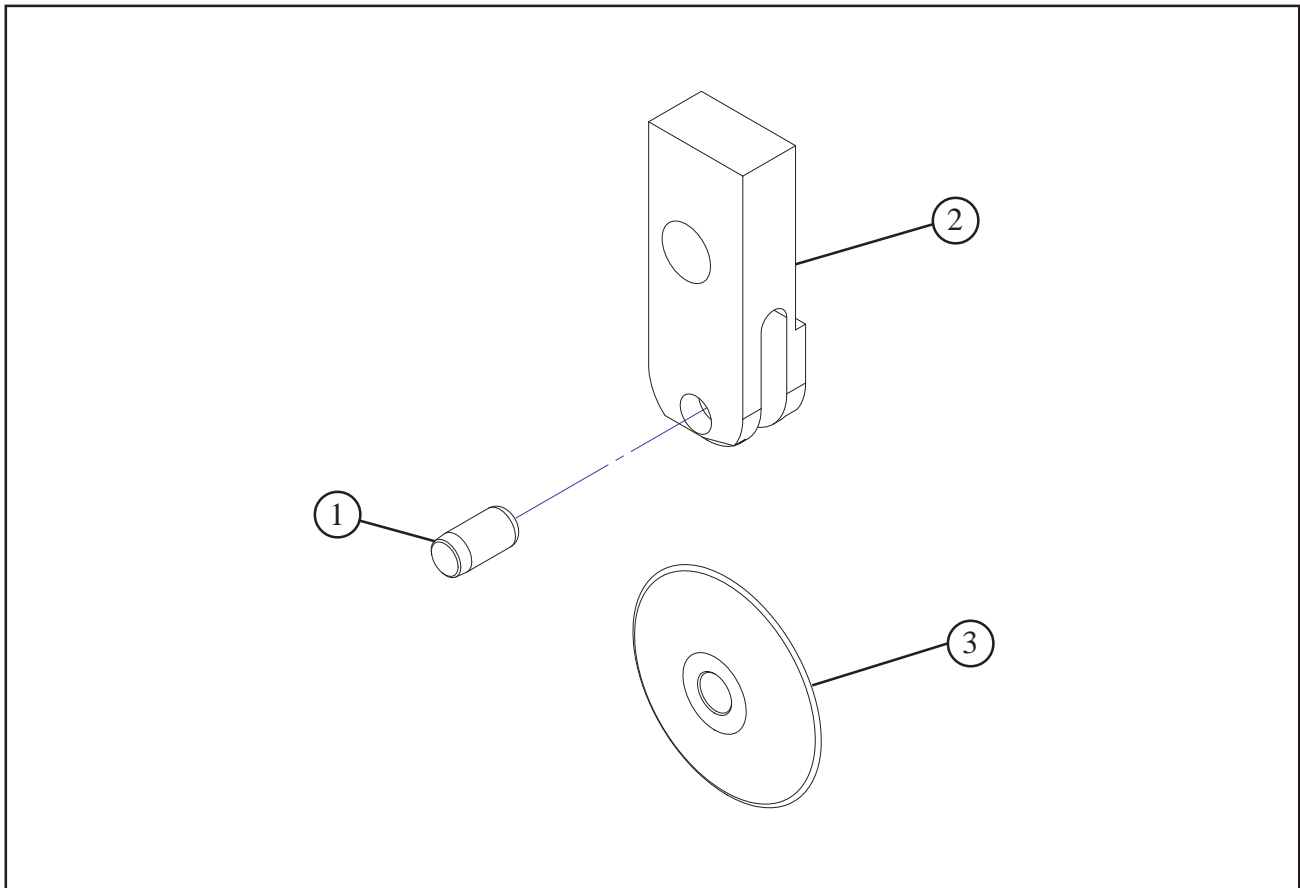

Parts List, 601SBCM and 602SBCM Wheel Assembly,  
Roller Cutter (P/N 61-0159)

Item No.	Part No.	Description	Qty
1.	32-0256	PIN, DOWEL, 1/8" DIA X 1/4"	1
2.	49-0556	HOLDER, TOOL, CUTTER WHEEL	1
3.	61-0158	WHEEL, CUTTER, 3/4"	1

600SBCM WRENCH ASSEMBLY, SPROCKET (P/N 36-0314)

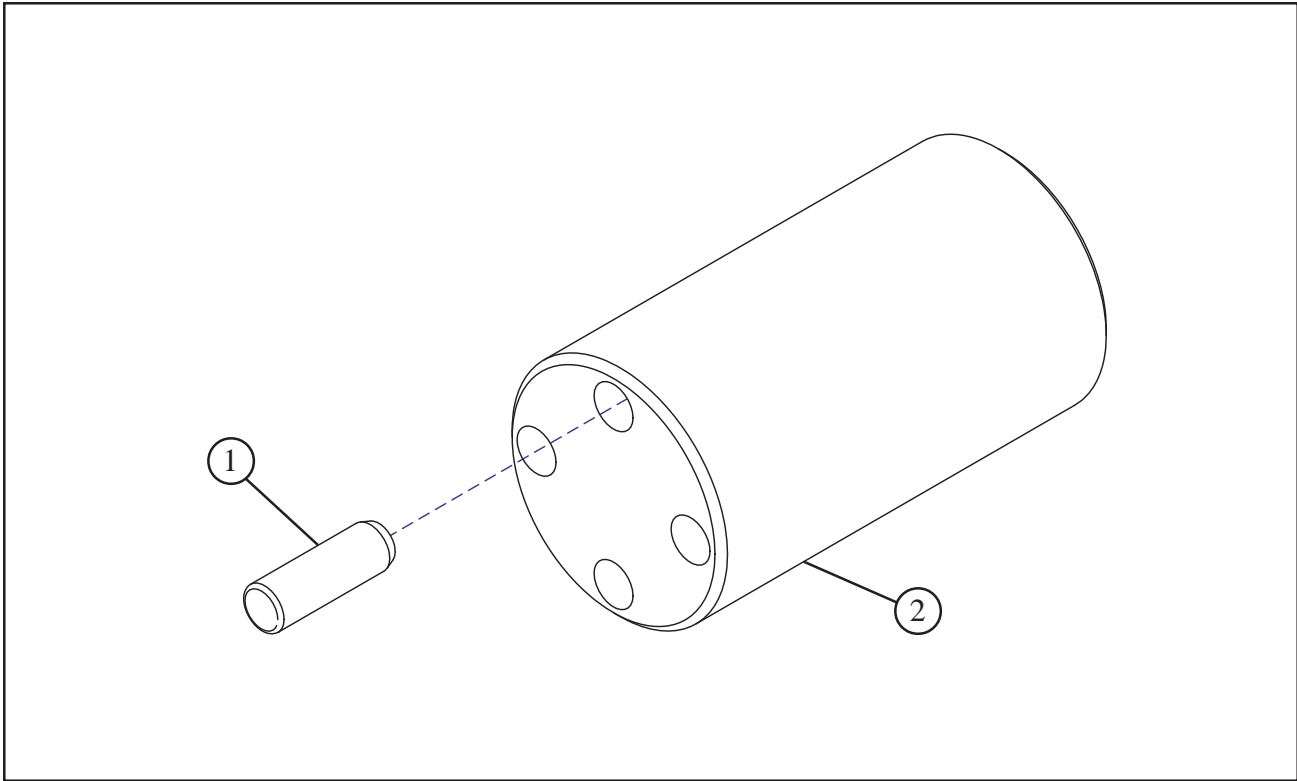

Parts List, 600SBCM Wrench Assembly, Sprocket (P/N 36-0314)

Item No.	Part No.	Description	Qty
1.	32-0220	PIN, DOWEL, 1/8" DIA X 3/8"	4
2.	36-0315	WRENCH, SPROCKET	1

601SBCM WRENCH ASSEMBLY, TORQUE BAR (P/N 36-0316)

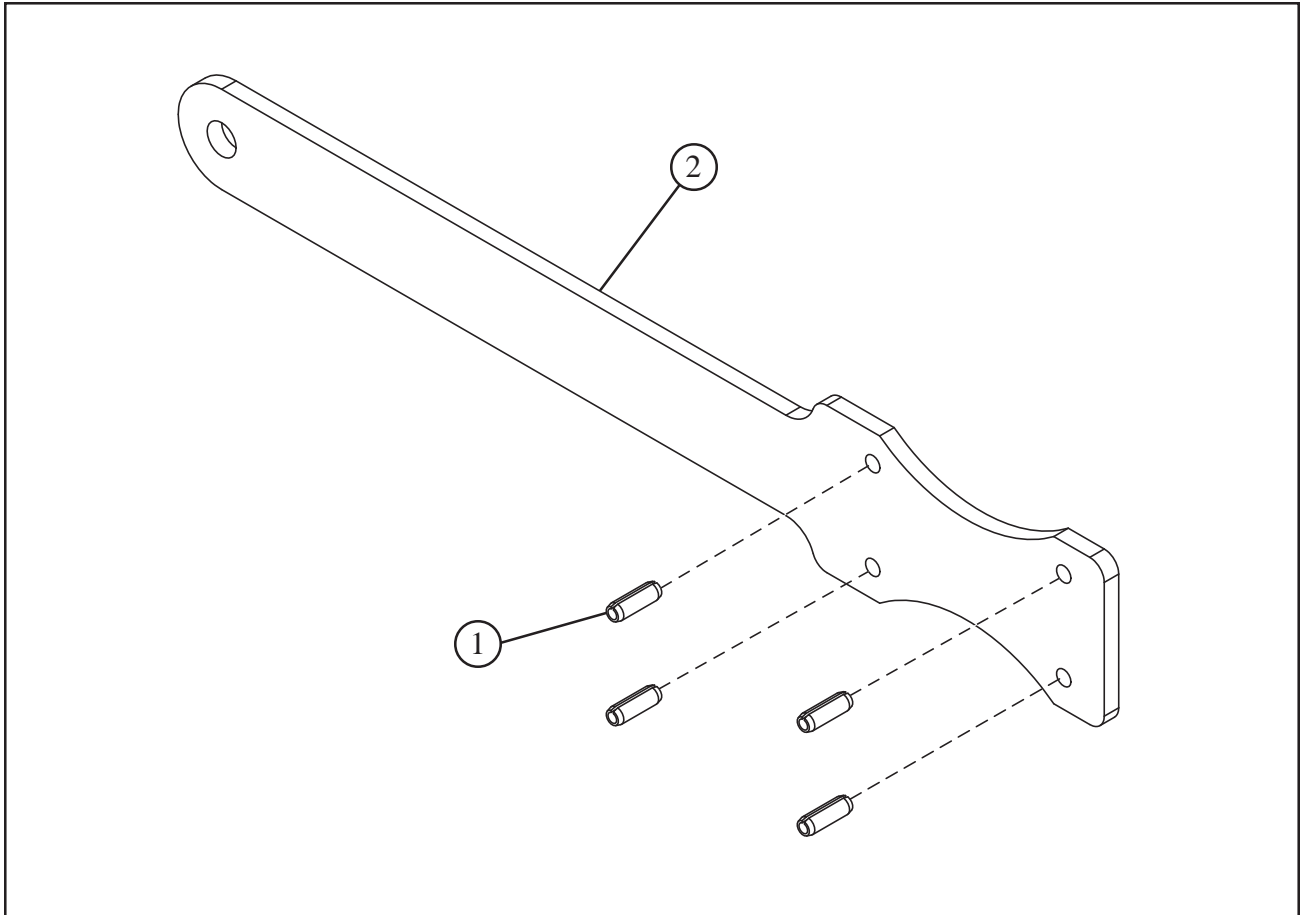

Parts List, 601SBCM Wrench Assembly, Torque Bar (P/N 36-0316)

Item No.	Part No.	Description	Qty
1.	32-0220	PIN, DOWEL, 1/8" DIA X 3/8"	4
2.	63-0191	BAR, TORQUE	1

**602SBCM AND 603SBCM  
WRENCH ASSEMBLY, TORQUE BAR (P/N 36-0344)**

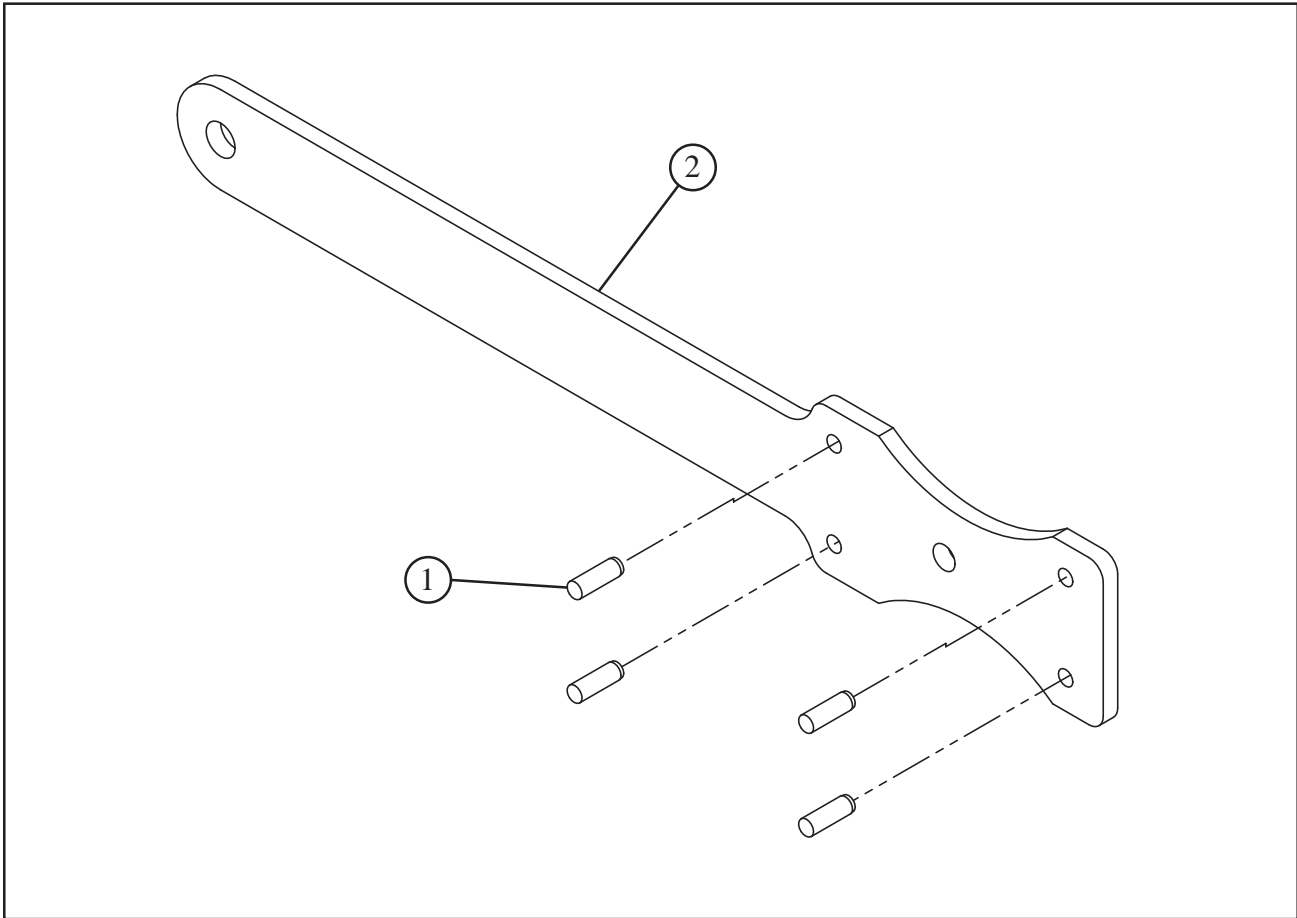

Parts List, 602SBCM and 603SBCM Wrench Assembly,  
Torque Bar (P/N 36-0344)

Item No.	Part No.	Description	Qty
1.	32-0220	PIN, DOWEL, 1/8" DIA X 3/8"	4
2.	63-0215	BAR, TORQUE	1

**600SBCM BLOCK ASSEMBLY, TRIPPER PIN  
REMOVAL/INSTALL (P/N 08-0804)**

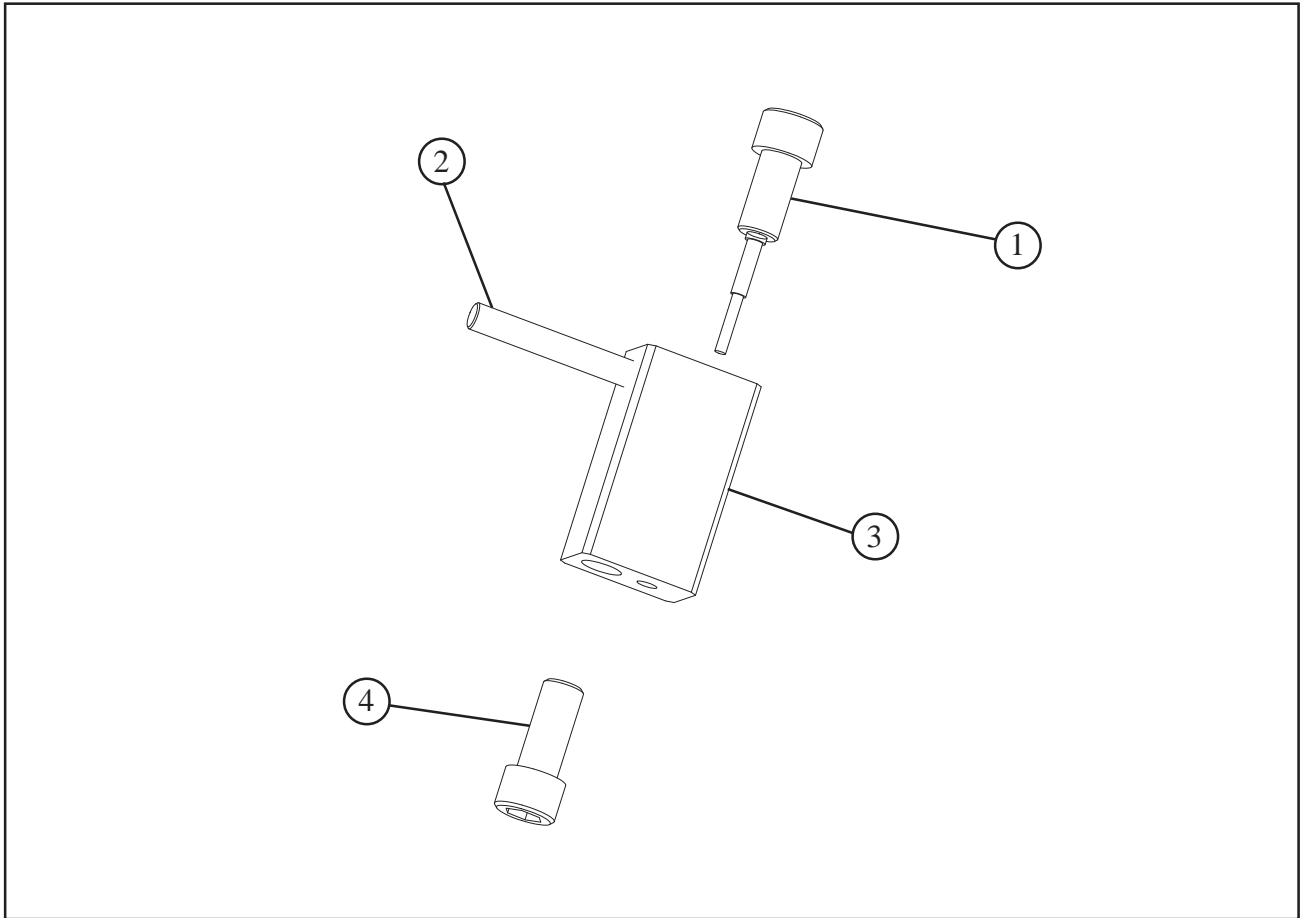

Parts List, 600SBCM Block Assembly, Tripper Pin  
Removal/Install (P/N 08-0804)

Item No.	Part No.	Description	Qty
1.	33-2503	SCREW ASSEMBLY, PIN REMOVAL	1
2.	32-0210	PIN, DOWEL, 1/4" DIA X 2"	1
3.	48-1882	BLOCK, TRIPPER PIN REMOVAL	1
4.	33-2490	SCREW ASSEMBLY, PIN INSTALLATION	1
NOTE SHOWN			
	36-0011	WRENCH , L, 5/16" HEX	1