

TABLE OF CONTENTS

CUSTOMER MESSAGE	Inside Front Cover
SAFETY PRECAUTIONS	3
GENERAL DESCRIPTION	5
SPECIFICATIONS	6
MAINTENANCE	7
OPERATION	8
TROUBLE SHOOTING	11
ILLUSTRATED PARTS BREAKDOWN	14
TOOL BIT RESHARPENING POLICY	Inside Back Cover
WARRANTY INFORMATION	Inside Back Cover

Copyright 1999 proprietary property of TRI TOOL Inc.
No reproduction, use, or duplication of the information
shown hereon is permitted without the express written
consent of TRI TOOL Inc.

SAFETY PRECAUTIONS

IN GENERAL:

When using rotating head cutting equipment, basic safety precautions should always be followed to reduce the risk of personal injury.

Operate this tool only in accordance with specific operating instructions.

WARNING:

Do not override the deadman switch on the power unit. Locking down, obstructing, or in any way defeating the deadman switch on the power drive unit may result in serious injury.

DRESS CONSIDERATIONS:

Use standard safety equipment. Hard hats, safety shoes, safety harnesses, protective clothes, and other safety devices should always be used when appropriate.

Use safety glasses. Do not operate cutting tools without eye protection.

Dress properly. Do not wear loose clothing or jewelry. They can be caught in rotating and moving parts. Avoid slippery floors or wear nonskid footwear. If you have long hair, wear protective hair covering to contain it.

WORK AREA:

Keep the work area clean. Cluttered work areas and benches invite injuries.

Consider the work area environment. Keep the area well lit. Keep electrical cords, cables, rags, rigging straps, etc. clear of rotating equipment. Do not use power cutting tools in the presence of flammable liquids and gasses.

Keep visitors away. Do not let visitors or untrained personnel at or near operating tools. Enforce eye protection requirements for all observers.

Do not over reach. Keep proper footing at all times.

Stay alert. Watch what you are doing. Use common sense. Do not operate tools when you are tired.

TOOL CARE:

Maintain tools with care. Keep tools in good operating condition. Sharp tool bits perform better and safer than dull tool bits. Well maintained tools function properly when needed.

Check for damaged parts. If a tool has malfunctioned, been dropped or hit, it must be checked for damage. Run no-load tests and feed function checks. Do a complete visual inspection.

Electric motors. Use only with proper AC voltage power sources and observe all normal electric shock hazard procedures.

Do not abuse power and control cords. Pulling or running over cords and cables can result in electrical shock hazards and malfunctions. Keep control and power cords out of all cutting fluids and water.

Hydraulic drives. Observe proper procedures for electrically driven power sources. Avoid damage to hydraulic lines. Keep quick-disconnects clean. Grit contamination causes malfunctions.

Air tools. Check the exhaust muffler. Broken or damaged mufflers can restrict air flow or cause excessive noise. Use air motors only with a filtered, lubricated and regulated air supply. Dirty air, low pressure air or over pressure air will cause malfunctions, including delayed starting.

AREA EQUIPMENT:

Secure work. Whenever possible use clamps, vises, chains and straps to secure pipe.

Make sure the tool is secured; it is safer to have both hands free to operate the tool.

TOOL USE:

Use the right tool and tool bit for the job. Do not use a tool which is incorrect for the job you are doing.

Keep the tool bits fully engaged in the tool bit holders. Loose bits are a safety hazard.

Disconnect power supply during setup and maintenance. Use all stop or shut-off features available when changing or adjusting tool bits, maintaining the tool, or when the tool is not in use.

Remove adjusting keys and wrenches before applying power to the equipment. Develop a habit of checking the tool before turning it on to make sure that all keys and wrenches have been removed.

Do not force tools. Tools and tool bits function better and safer when used at the feed and speed rate for which they were designed.

Do not reach into rotating equipment. Do not reach into the rotating head stock to clear chips, to make adjustments, or to check surface finish. A machine designed to cut steel will not stop for a hand or an arm.

Handle chips with care. Chips have very sharp edges and are hot. Do not try to pull chips apart with bare hands; they are very tough.

Avoid unintentional starts. Do not carry or handle tools with your hand on the operating switches or levers. Do not lay the tool down in a manner which will start the drive. Do not allow the tool to flip around or move when adjusting or changing tool bits.

Store idle tools properly. Disconnect tools from the power source and store in a safe place. Remove tool bits for safe handling of the tool.

GENERAL DESCRIPTION

The Model 576 AC SEVERMASTER™ has been converted to accommodate a Chipless Sever Module. The custom 576 AC retains the Tri Tool Quick Lock Collet Closure Mechanism™ that actuates the collet with a single lever stroke and provides for simple collet changes. The custom 576 AC is also fitted with a Burnishing Module, which is designed to roll back any burrs that remain after the severing operation.

SPECIFICATIONS

576 AC with Chipless Sever Module:

Weight:

140 lbs. (308 kg)

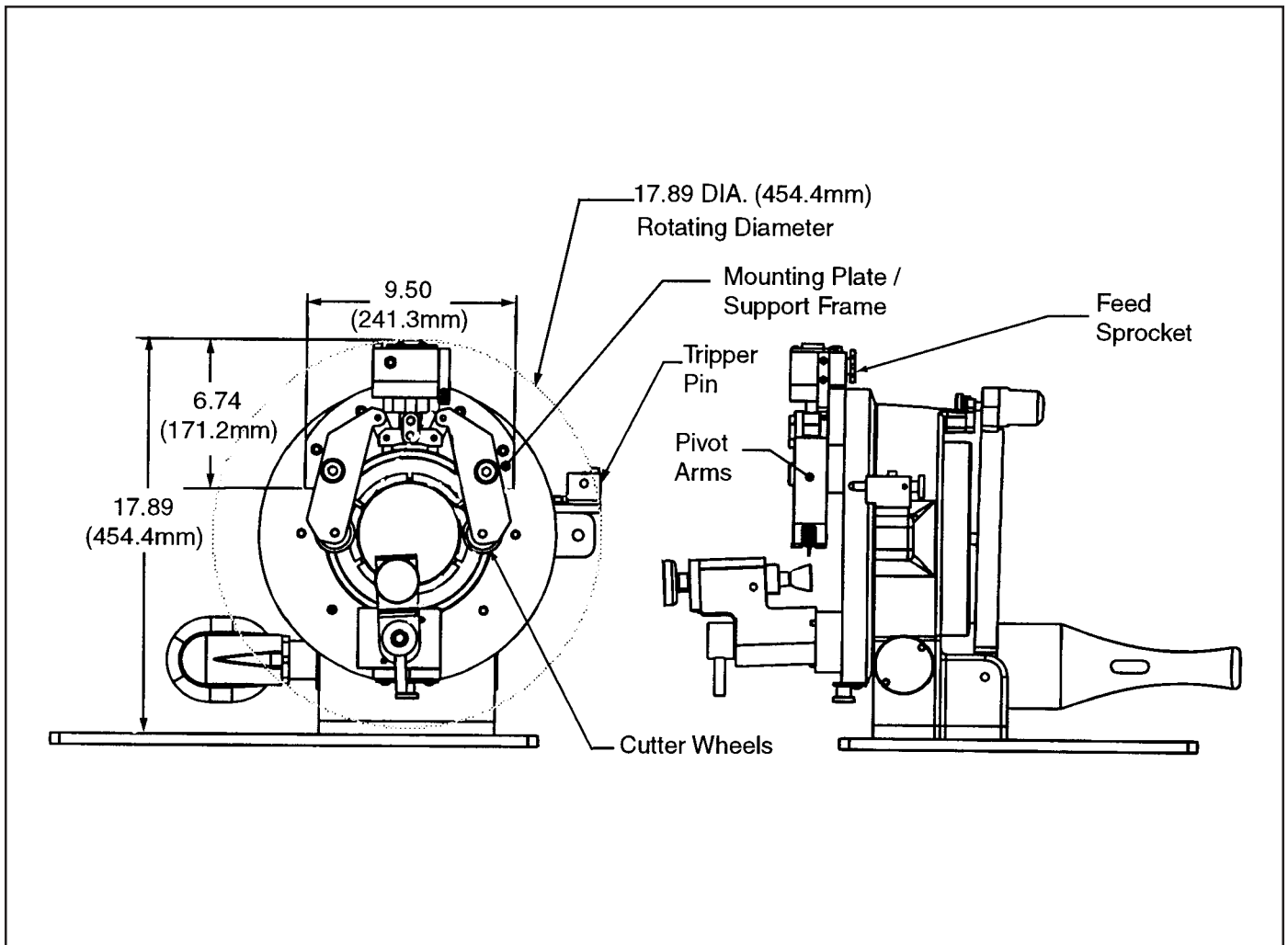

Housing Hole Pattern

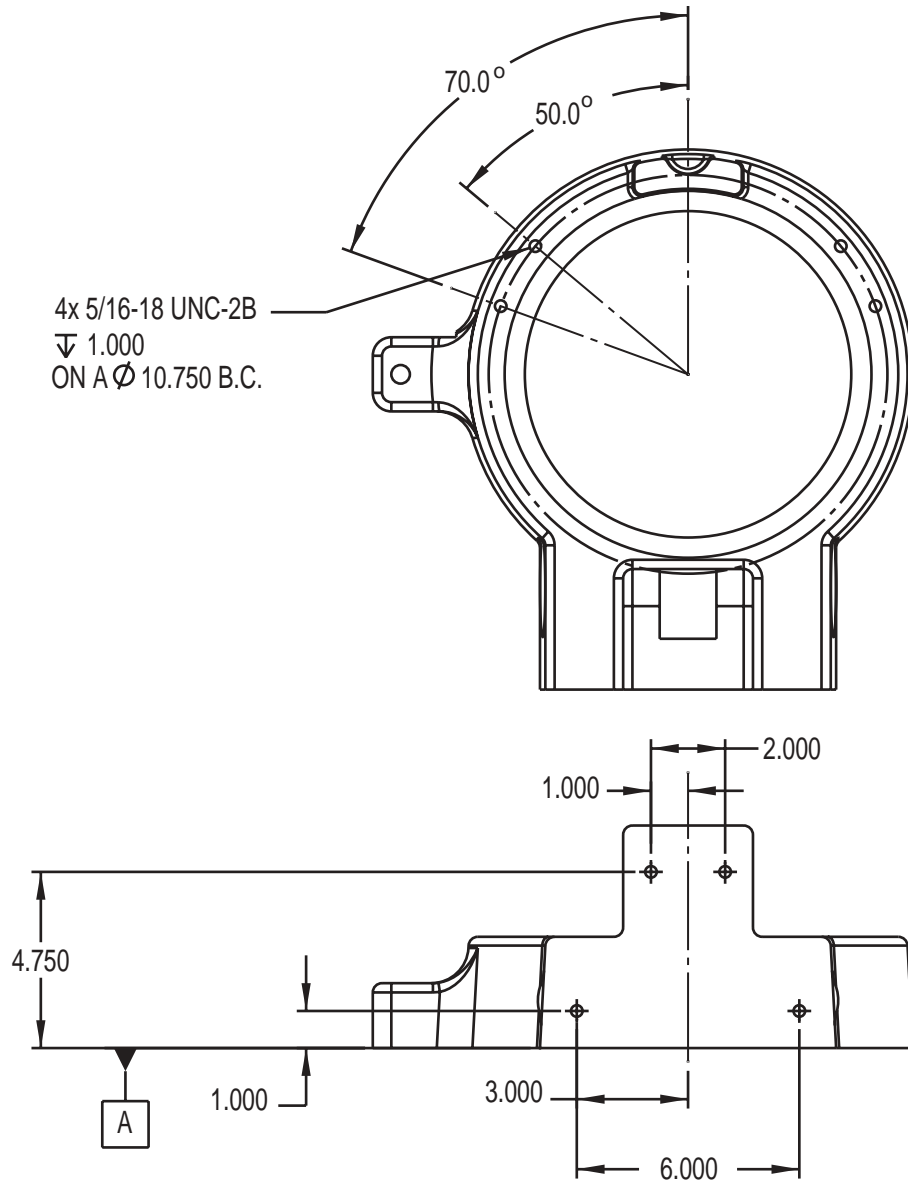

MAINTENANCE

All Components should be cleaned and coated with a light film of oil prior to use.

Use a clean non-detergent oil, preferably SAE 10 (90 SSU) or lighter.

Daily Maintenance Schedule:

Daily Maintenance should include a visual inspection of all parts for damage due to chips, impact or improper use.

Repair or replace broken or damaged parts as necessary.

Wipe the machine clean of cutting fluids, dirt and grime and then coat it with a light film of oil.

After every 20 hours of operation:

Lubricate the slides on the carriage block, the hinges, cutter wheel and the pivot posts.

Non-scheduled Maintenance:

Thoroughly clean and check the Chipless Sever Module in the event of feed problems.

Storage:

If the Chipless Sever Module is to be stored or if it will remain out of service for a significant period of time (30 days or more), it should be thoroughly cleaned, lubricated and sprayed with a rust preventative prior to storage.

OPERATION

Become familiar with the custom 576 AC SEVERMASTER™ before attempting to operate.

CAUTION: Use eye protection at all times when operating this machine.

NOTE: Use of dull cutter wheels, cutter wheels not manufactured by Tri Tool, Inc. or cutter wheels not originally provided with the system may result in poor performance. This also constitutes abuse of this machine and therefore voids the Tri Tool, Inc. factory warranty.

NOTE: Slowly rotate machine to insure that no machine parts violate the maximum rotating diameter. Then increase RPM to cutting speed.

Tripper Pin Alignment:

1. Rotate the Chipless Sever Module until the feed sprocket is in the proximity of the tripper pin.
2. Set the tripper pin to engage the feed sprocket with a .020 - .030" gap from the roof of the sprocket.

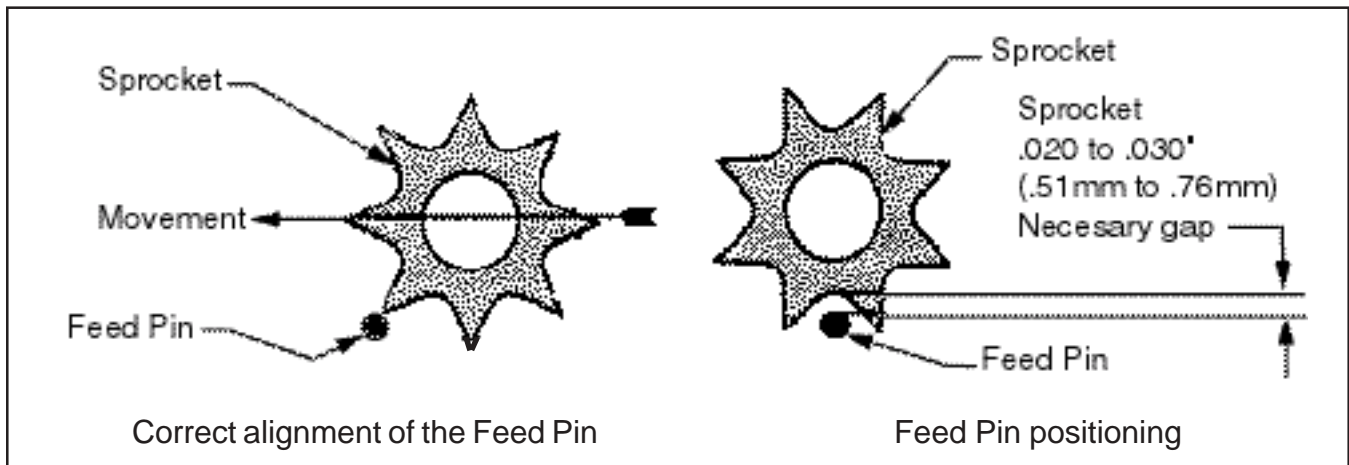

CAUTION: If the feed sprocket is not correctly aligned before operation, serious damage could occur or destroy the Tripper Pin Assembly and/or the feed sprocket .

Do not bump the cutter wheels.

Cutting Wheel Replacement

To remove the cutting wheels, loosen the retaining set screws at the bottom of the cutting arms.

Push out the cutting wheel pin, using the end of an “L” shaped Allen wrench pushing from the backside of the pin.

Slide out the wheels, the spring washers, and the thrust washer.

Inspect for damage, and replace as needed.

To reinstall, proceed in reverse as above. (See drawing for proper washers and wheel configuration.)

In case of wheel breakdown during a cut, pull in the tripper pin to stop the feed and stop the drive motor.

Turn the feed sprocket to release the cutting arms.

Remove the cutting wheels and washers as instructed above.

Install the new wheels and washers as instructed above.

Align the feed sprocket with the tripper pin.

Resume the cutting operation.

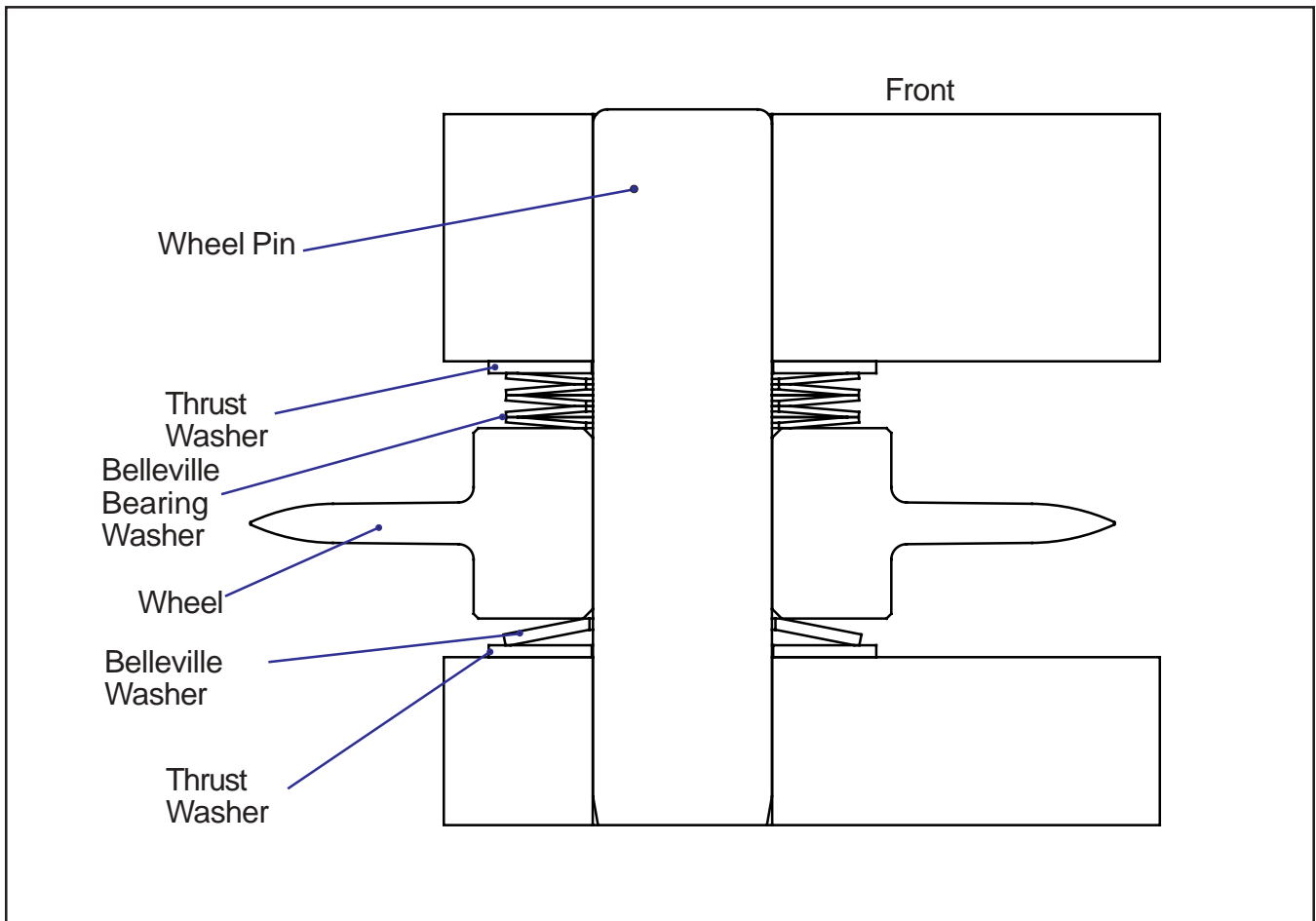

Burnishing Module:

The Burnishing Module has ability to be adjusted radially and axially. The radial adjustment is achieved by turning the knurled knob that moves the Tool Block in either direction until the desired location is found. The axial location adjustment is achieved by feeding the burnishing wheel into the severed canister.

TROUBLE SHOOTING

Problem: The Tool Bit Chatters.

The tool bit is loose or overextended.
The tool bit is damaged.
The tool holder is too loose in the slides.
The cutting speed is too fast.
The clamping pads are loose on the pipe or tube.
Cutting fluid is required.
The main bearing pre-load is loose.

Problem: There is excessive Tool Bit wear.

The pipe or tube material is too hard or abrasive.
The cutting speed is too fast.
Cutting fluid is required.
A dull Tool Bit is causing surface hardening conditions (Stainless pipe or tubing). There is scale or other foreign matter on the pipe or tube, which is dulling the tool bit at the start of the cut.
The tool bit is incorrect for the material being cut.

Problem: The surface finish is rough.

The tool bit is dull, chipped, etc.
Metal build/up on the cutting edge of the tool bit is creating a false cutting edge.
Cutting fluid is required.
The cutting speed is incorrect.

Problem: The tool holder is not feeding.

The feed pin is broken or out of position.
The feed sprocket shear pin is broken.
The feed screw is stripped.
The feed nut is stripped.
The slide rails are too tight.

Problem: There is a loss of air power.

The air supply pressure is too low.
The air filter is plugged.
The air line size is insufficient.
The air line is too long.

Problem: There is a loss of hydraulic power.

The hydraulic supply pressure is too low.

The hydraulic filter is plugged.

The hydraulic line size is insufficient.

The hydraulic line is too long.

Problem: The tool bit will not reach the work.

Incorrect tool blocks are installed for the size of the pipe or tube being worked on incorrect tool bit is installed.

Problem: The air motor will not start.

The air power supply is shut off.

The air motor is damaged and will not run free. The air motor needs lubrication.

Add lubrication and do not run the air motor for a few minutes, then try running the motor. Tap on the side of the air motor casing lightly with a piece of wood or with a soft rubber mallet just in case the vanes may be sticking.

Sand or other foreign material may be in the vanes of the air motor.

Problem: The hydraulic motor will not start.

The hydraulic power supply is shut off.

The hydraulic motor is damaged and will not run free.

BLANK PAGE

ILLUSTRATED PARTS BREAKDOWN

Model 576AC Sub-assembly, Group A (P/N 02-2226)

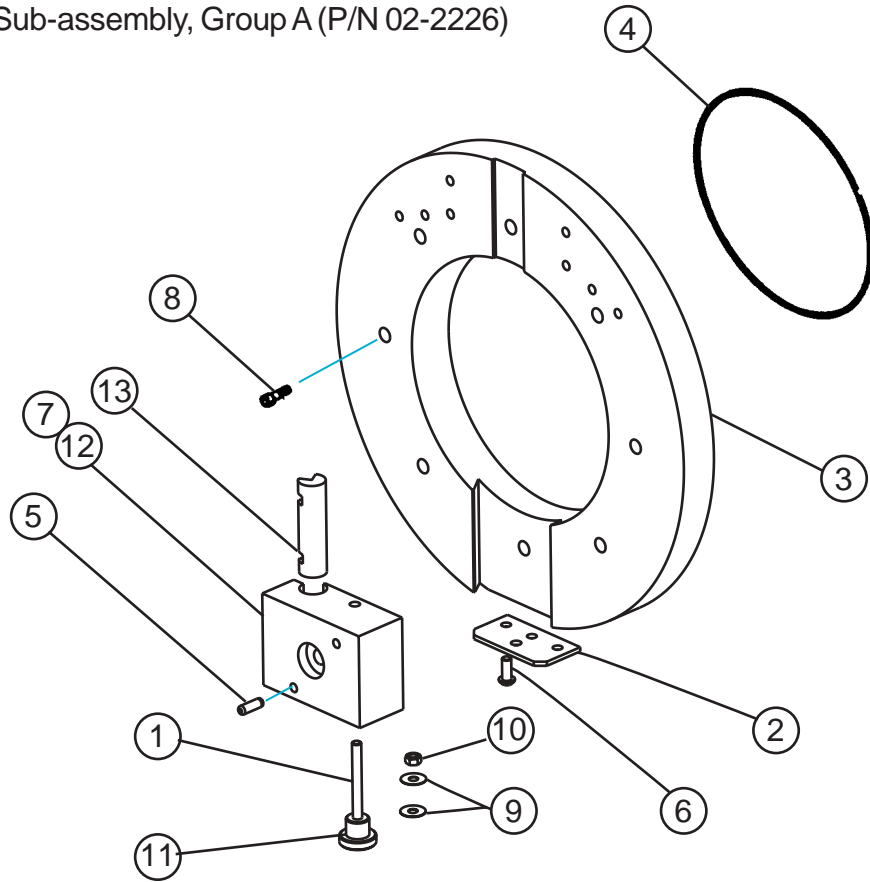

Parts List, Model 576AC Sub-assembly, Group A (P/N 02-2226)

Item No.	Part No.	Description	Qty
1.	23-0357	ROD, THREADED	1
2.	24-1778	PLATE, THRUST	1
3.	24-1779	PLATE, MAIN	1
4.	28-0262	O-RING	1
5.	32-0140	PIN, DOWEL	2
6.	33-0286	SCREW, BUTTON HEAD (1/4-20 X 5/8")	3
7.	33-1322	SCREW, SET, OVAL POINT (1/4-20 X 3/4")	2
8.	33-2033	SCREW, CAP, ZINK PL (1/4-20 X .75")	6
9.	34-0219	WASHER, THRUST	2
10.	35-0203	NUT, LOCKING	1
11.	42-0068	KNOB	1
12.	48-1293	BLOCK, TOOL	1
13.	62-0049	LOCK, CAM	1

Model 576AC Sub-assembly, Group B (P/N 02-2226)

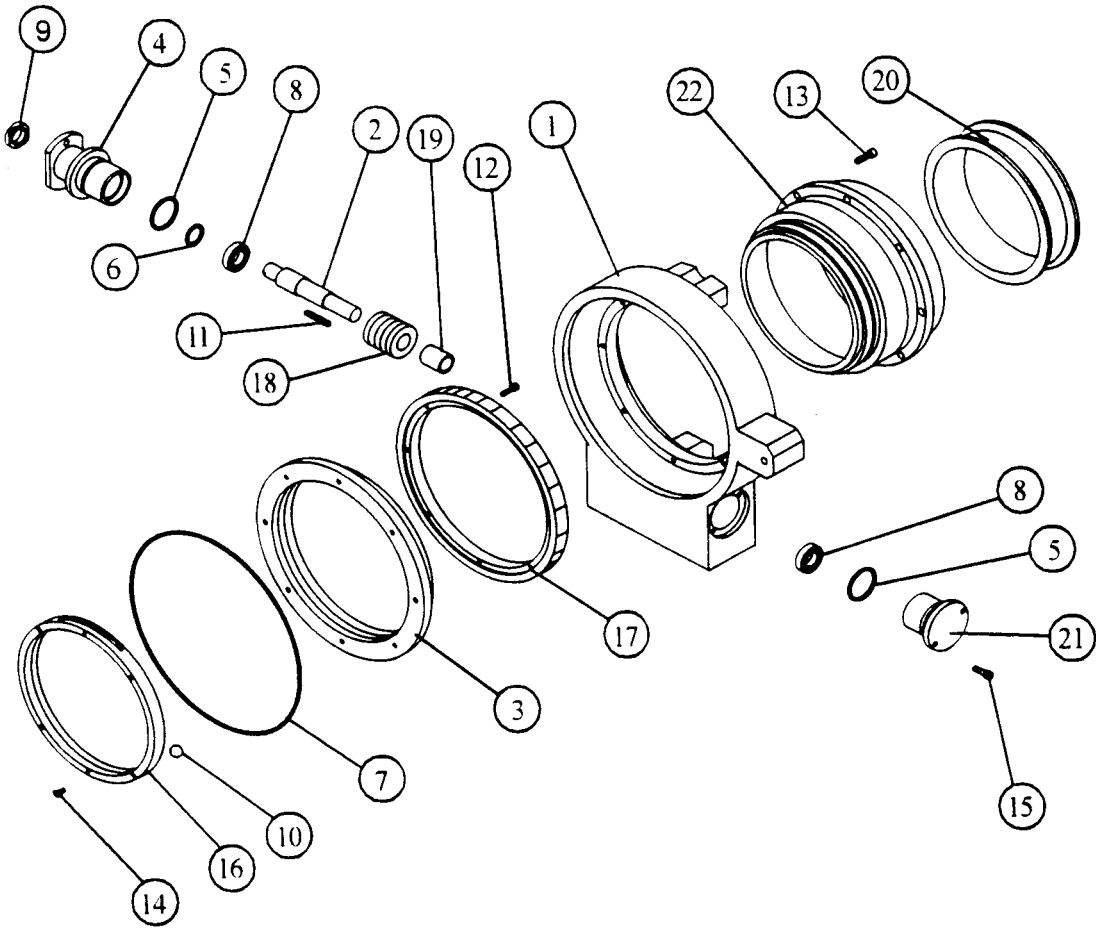

576AC Chipless Sever Module

Parts List, Model 576AC Sub-assembly, Group B (P/N 02-2226)

Item No.	Part No.	Description	Qty
1.	19-0777	HOUSING, MAIN	1
2.	20-0651	SHAFT, DRIVE	1
3.	20-0652	SHAFT, MAIN	1
4.	27-0694	ADAPTOR, MOTOR	1
5.	28-0264	O-RING	2
6.	28-0245	SEAL, GREASE	1
7.	28-0263	O-RING	1
8.	29-0020	BEARING, BALL	2
9.	29-0096	BEARING, BALL	1
10.	30-2612	BEARING, BALL, STEEL (3/8 dia)	72
11.	31-0142	KEY	1
12.	33-0030	SCREW, CAP (#10-24 x .75)	8
13.	33-0041	SCREW, CAP (1/4-20 x .88)	8
14.	54-0398	PLUG, PRESSURE	4
15.	33-2033	SCREW, CAP (1/4-20 x .75, Zinc Plt)	4
16.	35-0534	NUT, ADJUSTMENT, BEARING, RACE	1
17.	39-0815	GEAR, MAIN, WORM	1
18.	39-0819	GEAR, WORM	1
19.	44-0473	SPACER	1
20.	44-0474	SPACER, COLLET	1
21.	46-0446	SLEEVE, END	1
22.	46-0448	SLEEVE, MAIN INNER	1
	29-0362	BEARING, INNER RACE	ref
	46-0467	SLEEVE, MAIN INNER RACE	ref

Model 576AC Sub-assembly, Group C (P/N 02-2226)

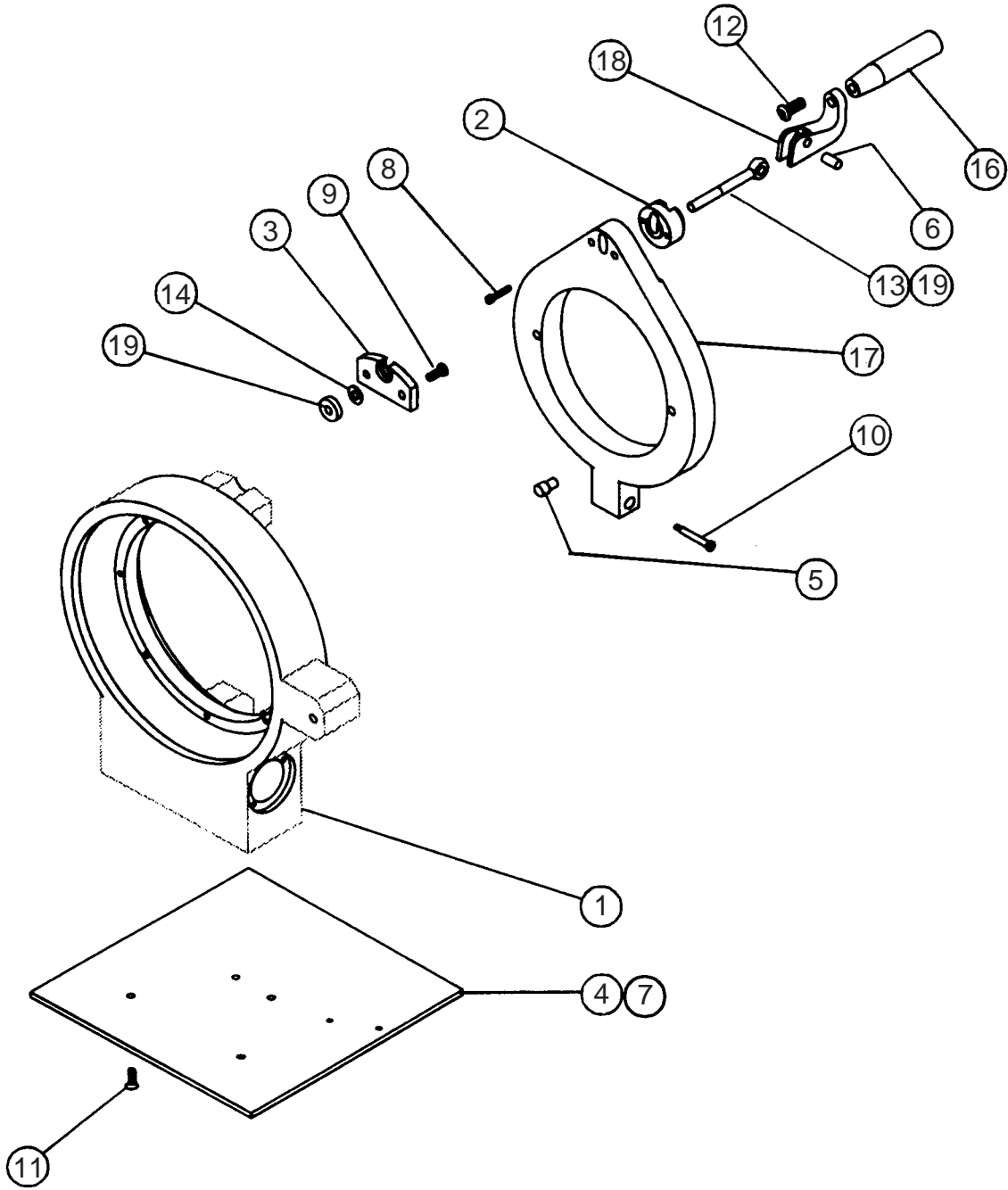

576AC Chipless Sever Module

Parts List, Model 576AC Sub-assembly, Group C (P/N 02-2226)

Item No.	Part No.	Description	Qty
1.	19-0777	HOUSING, MAIN	ref
2.	20-0633	SHAFT, CLAMP	1
3.	24-1511	PLATE, CLAMP	1
4.	24-1525	PLATE, STAND	1
5.	30-2611	BUTTON, SPHERICAL	2
6.	32-0118	PIN, DOWEL (3/8 dia x .75)	1
7.	44-0539	SPACER	2
8.	33-0032	SCREW, CAP (#10-24 x 1.00)	2
9.	33-0300	SCREW, BUTTON HEAD (3/8-16 x 1.00)	2
10.	33-1950	SCREW, SHOULDER (.50 dia x 2.50)	1
11.	33-0372	SCREW, FLAT HEAD (5/16-18 x 1 1/2")	4
12.	33-2006	SCREW, BUTTON HEAD (3/8-16 x 1.00, SS)	1
13.	33-2030	EYEBOLT	1
14.	34-0134	WASHER, SET, SELF ALIGN (3/8)	1
15.	35-0139	NUT, CHECK (3/8-16)	1
16.	41-0125	HANDLE	1
17.	47-1163	BRACKET, HINGE	1
18.	62-0110	CAM, CLAMP	1
19.	33-0619	SCREW, SET, CUP POINT (10-32 X .25")	1
Not Shown:			
	36-0005	WRENCH, L, 1/8" HEX	1
	36-0007	WRENCH, L, 5/32" HEX	1
	36-0008	WRENCH, L, 3/16" HEX	1
	36-0012	WRENCH, L, 3/8" HEX	1
	36-0020	WRENCH, T, 5/32" HEX	1

Drive Kit, Electric (P/N 05-1353)

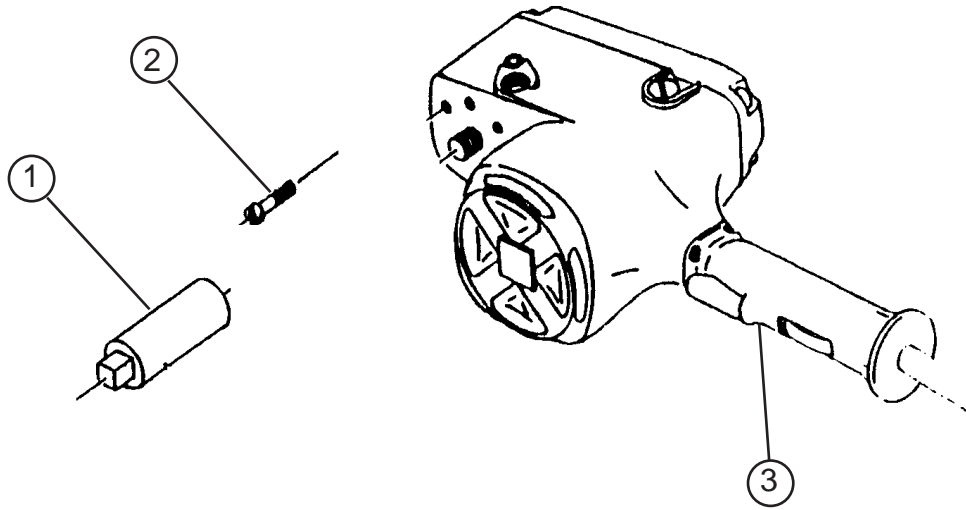

Parts List, Electric Drive Kit 110 VAC (P/N 05-1353)

Item No.	Part No.	Description	Qty
1.	27-0693	ADAPTOR, DRIVE	1
2.	33-0021	SCREW, CAP	4
3.	58-0027	MOTOR, ELECTRIC	1

Chipless Sever Module (P/N 02-2312)

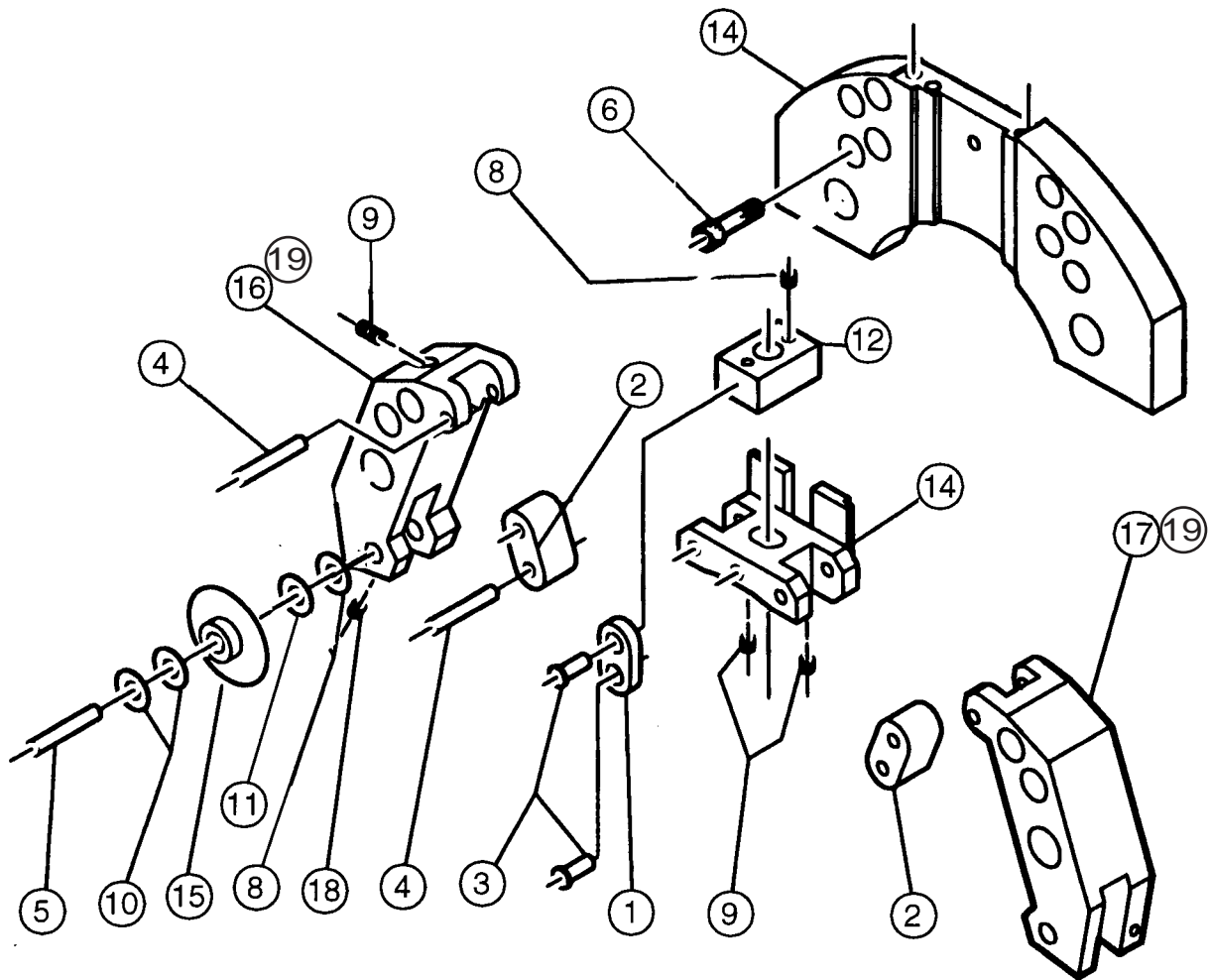

Parts List, Sever Module, Chipless (P/N 02-2312)

Item No	Part No	Description	Qty.
1.	24-1193	HINGE	2
2.	24-1776	HINGE	2
3.	32-0447	PIN, FLANGE	4
4.	32-0170	PIN, DOWEL	4
5.	32-0448	PIN	2
6.	33-0057	SCREW, CAP (5/15 - 18 x 1 1/4")	8
7.	34-0362	WASHER, BEARING	10
8.	33-0488	SCREW, SET, CUP POINT (10-24 X 1/4")	8
9.	33-0492	SCREW, SET, CUP POINT (10-24 X 1/2")	4
10.	34-0272	WASHER, BELLEVILLE	8
11.	34-0107	WASHER, THRUST	4
12.	35-0384	NUT, FEED	1
13.	47-0834	BRACKET	1
14.	48-0797	BLOCK, CARRIAGE	1
15.	61-0063	WHEEL, CUTTER	2
16.	63-0179	ARM, LEFT	1
17.	63-0180	ARM, RIGHT	1
18.	33-0500	SCREW, SET, CUP POINT (1/4-20 X 5/16")	2
19.	33-2148	BOLT, SHOULDER (3/4 X 1 1/4")	2

NOT SHOWN:

47-1301	BRACKET, SUPPORT	1
33-0030	SCREW, CAP (10-24 X 3/4")	4

Right Angle Feed Assembly (P/N 19-0644)

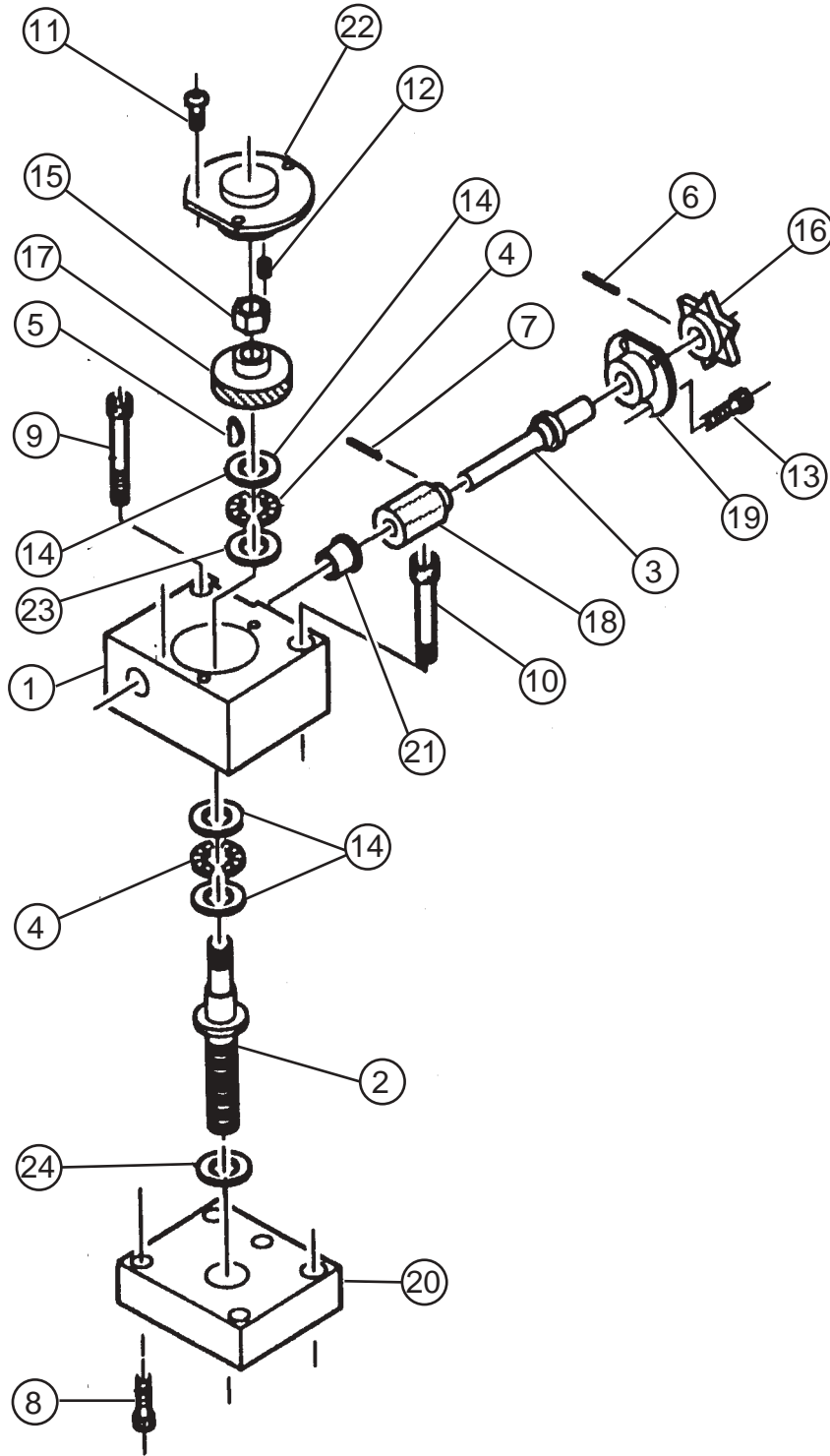

Parts List, Feed Assembly, Right Angle (P/N 19-0644)

Item No	Part No	Description	Qty.
1.	19-0634	HOUSING, FEED	1
2.	20-0530	SHAFT, FEED	1
3.	20-0531	SHAFT, WORM	1
4.	29-0107	BEARING, THRUST	2
5.	31-0004	KEY	1
6.	32-0019	PIN, ROLL	1
7.	32-0177	PIN, DOWEL	1
8.	33-0041	SCREW, CAP (1/4-20 X 7/8")	3
9.	33-0048	SCREW, CAP 1/4-20 X 2 1/2")	1
10.	33-0062	SCREW, CAP (5/16-18 X 2 1/2")	1
11.	33-0279	SCREW, BUTTON HEAD (10-24 X 1/2")	3
12.	33-0465	SCREW, SET, CUP POINT (#6-32 X 1/8")	1
13.	33-1807	SCREW, COVER RETAINING	4
14.	34-0163	WASHER, THRUST	3
15.	35-0386	NUT, JAM	1
16.	38-0116	SPROCKET, 6 POINT	1
17.	39-0693	GEAR, WORM	1
18.	39-0694	WORM	1
19.	43-0410	COVER. SHAFT	1
20.	44-0395	SPACER	1
21.	45-0211	BUSHING, FLANGE	1
22.	54-0345	CAP, SHAFT	1
23.	34-0162	WASHER	1
24.	34-0185	WASHER	1

Collet Assembly (P/N 30-2869)

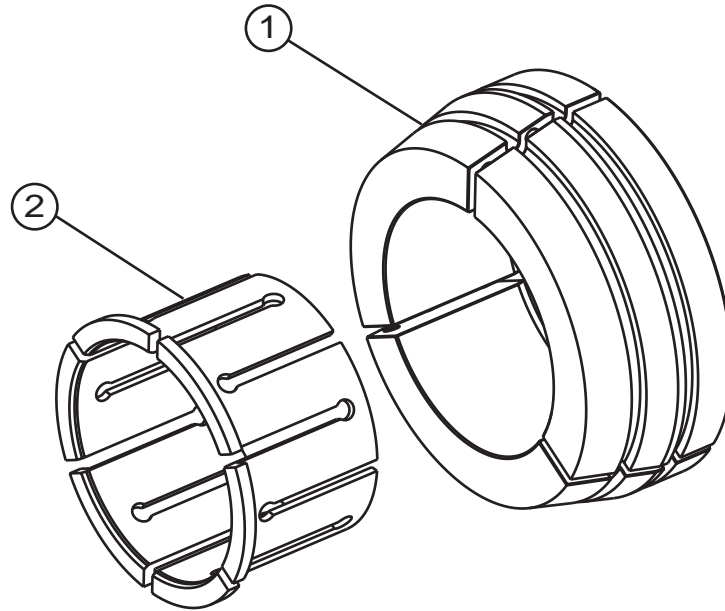

Parts List, Collet Assembly (P/N 30-2869)

Item No	Part No	Description	Qty.
1.	30-2867	COLLET (DIA 4.920")	1
	40-0248	SPRING, COMP.	9
	40-0238	SPRING, EXT.	2
	40-0249	SPRING, EXT.	1
	40-0250	SPRING, EXT.	1
	32-0516	PIN, SS	9
2.	30-2868	ADAPTOR, COLLET(DIA 4.620")	1

Tripper Bracket Assembly (P/N 48-0799)

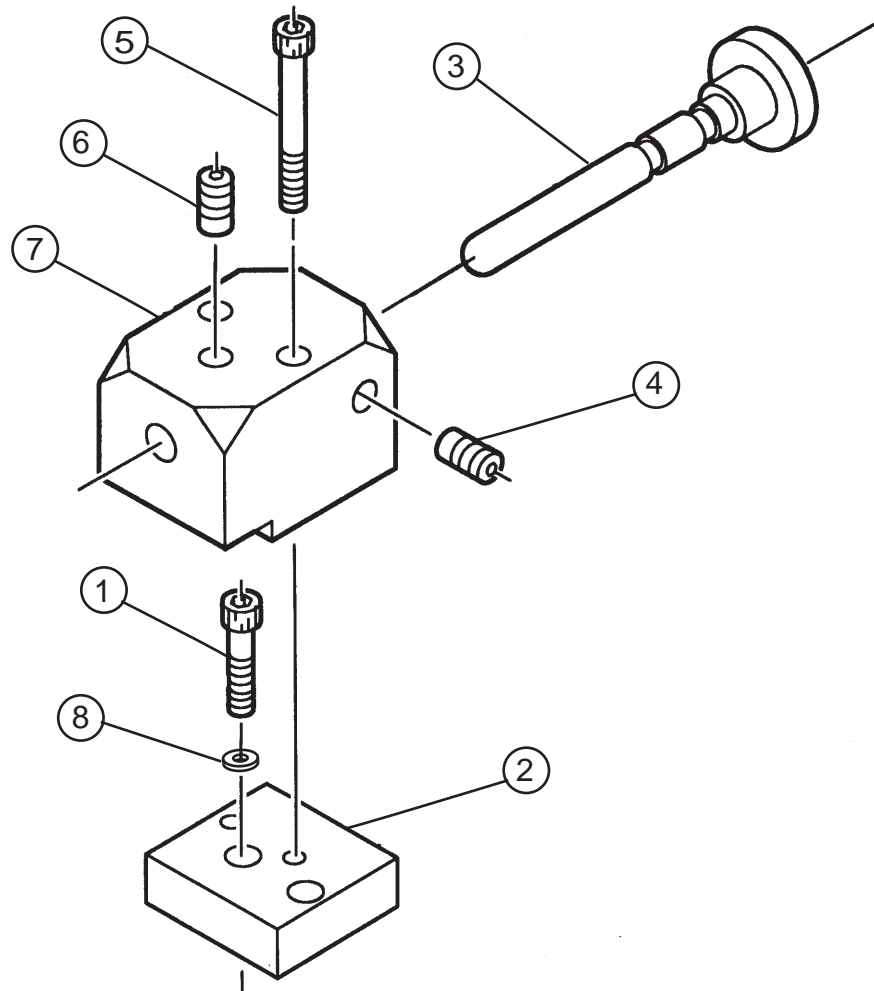

Parts List, Bracket Assembly ,Tripper (P/N 48-0799)

Item No	Part No	Description	Qty.
1.	33-0043	SCREW, CAP (1/4-20 X 1 1/4")	2
2.	44-0534	SPACER	1
	48-0478	TRIPPER ASSEMBLY	1
3.	14-0044	SHAFT ASSEMBLY, TRIPPER	1
4.	30-0125	BALL PLUNGER	1
5.	33-0045	SCREW, CAP (1/4-20 X 1 3/4")	2
6.	33-0903	SCREW, SET, HALF DOG (1/4-20 X 5/16")	1
7.	48-0479	BLOCK, TRIPPER	1
8.	34-0026	WASHER, FLAT (1/4 X 5/8 X 7/64")	2

Burnishing Module Assembly (P/N 82-0145)

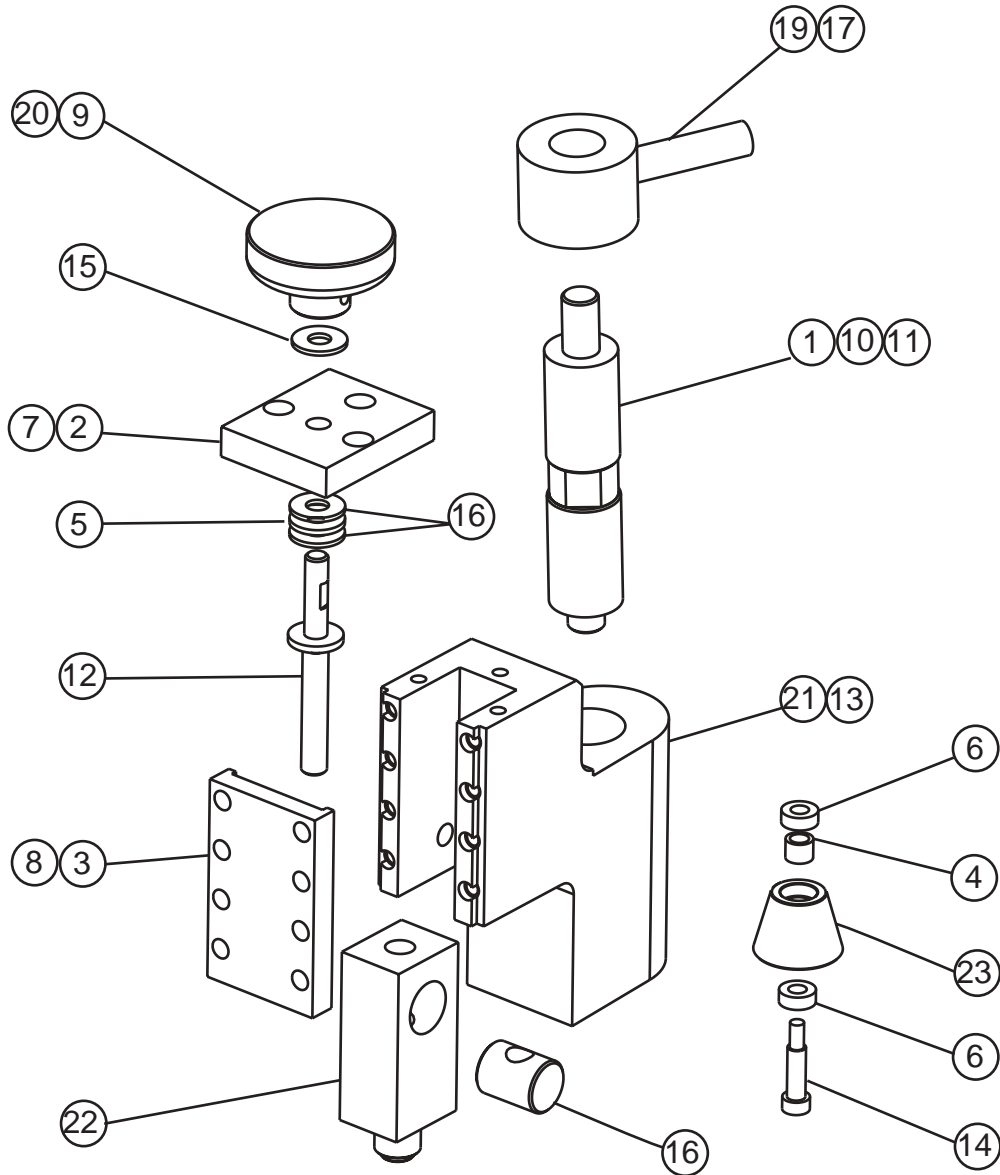

Parts List, Module Assembly, Burnishing (P/N 82-0145)

Item No	Part No	Description	Qty.
1.	20-0673	SHAFT, PIVOT	1
2.	24-1047	PLATE, TOP	1
3.	24-1777	PLATE, COVER	1
4.	44-0535	SPACER, BEARING	1
5.	29-0190	BEARING, THRUST	1
6.	29-0399	BEARING, BALL	2
7.	33-0039	SCREW, CAP (1/4-20 X 5/8")	3
8.	33-0287	SCREW, BUTTON HEAD (1/4-20 X 3/4")	8
9.	33-0499	SCREW, SET, CUP POINT (1/4-20 X 1/4")	1
10.	33-0557	SCREW, SET, CUP POINT (1/2-20 X 1/4")	1
11.	33-0559	SCREW, SET, CUP POINT (1/2-13 X 1 3/4")	1
12.	33-2218	SCREW, FEED, LH	1
13.	33-1735	SCREW, SET, BRASS TIP (3/8-16 X 1/4")	1
14.	33-2220	BOLT, SHOULDER (1/4 X 3/4")	1
15.	34-0108	WASHER, THRUST	1
16.	34-0258	WASHER, THRUST	1
17.	34-0202	WASHER, THRUST	2
18.	35-0583	NUT, FEED. LH	1
19.	41-0148	LEVER ASSEMBLY, ADJUSTMENT	1
20.	42-0099	KNOB, FEED	1
21.	47-1303	BRACKET, HINGE	1
22.	49-0404	HOLDER, TOOL	1
23.	61-0116	WHEEL, BURNISHING	1