

TABLE OF CONTENTS

CUSTOMER MESSAGE	Inside Front Cover
SAFETY PRECAUTIONS	3
SPECIFICATIONS	6
MAINTENANCE	7
OPERATION	8
CUTTING SPEEDS AND FEEDS	10
SADDLE SETS	12
TOOL BITS	15
TROUBLE SHOOTING	16
ACCESSORIES	18
ILLUSTRATED PARTS BREAKDOWN	19
DEWALT SAFETY INSTRUCTIONS	23
TOOL BIT RESHARPENING POLICY	Inside Back Cover
WARRANTY INFORMATION	Inside Back Cover

Copyright 2006
Proprietary property of TRI TOOL Inc.
No reproduction, use, or duplication of the information
shown hereon is permitted without the express written
consent of TRI TOOL Inc.

SAFETY PRECAUTIONS

IN GENERAL

When using rotating head cutting equipment, basic safety precautions should always be followed to reduce the risk of personal injury.

Operate this tool only in accordance with specific operating instructions.

WARNING:

Do not override the deadman switch on the power unit. Locking down, obstructing, or in any way defeating the deadman switch on the power drive unit may result in serious injury.

DRESS CONSIDERATIONS

Use standard safety equipment. Hard hats, safety shoes, safety harnesses, protective clothes, and other safety devices should always be used when appropriate.

Use safety glasses. Do not operate cutting tools without eye protection.

Dress properly. Do not wear loose clothing or jewelry. They can be caught in rotating and moving parts. Avoid slippery floors or wear nonskid footwear. If you have long hair, wear protective hair covering to contain it.

WORK AREA

Keep the work area clean. Cluttered work areas and benches invite injuries.

Consider the work area environment. Keep the area well lit. Keep electrical cords, cables, rags, rigging straps, and etc. clear of rotating equipment. Do not use power-cutting tools in the presence of flammable liquids and gasses.

Keep visitors away. Do not let visitors or untrained personnel at or near operating tools. Enforce eye protection requirements for all observers.

Do not over reach. Keep proper footing at all times.

Stay alert. Watch what you are doing. Use common sense. Do not operate tools when you are tired.

TOOL CARE

Maintain tools with care. Keep tools in good operating condition. Sharp tool bits perform better and safer than dull tool bits. Well maintained tools function properly when needed.

Check for damaged parts. If a tool has malfunctioned, been dropped or hit, it must be checked for damage. Run no-load tests and feed function checks. Do a complete visual inspection.

Electric motors. Use only with proper AC voltage power sources and observe all normal electric shock hazard procedures.

Do not abuse power and control cords. Pulling or running over cords and cables can result in electrical shock hazards and malfunctions. Keep control and power cords out of all cutting fluids and water.

Hydraulic drives. Observe proper procedures for electrically driven power sources. Avoid damage to hydraulic lines. Keep quick-disconnects clean. Grit contamination causes malfunctions.

Air tools. Check the exhaust muffler. Broken or damaged mufflers can restrict air flow or cause excessive noise. Use air motors only with a filtered, lubricated and regulated air supply. Dirty air, low-pressure air or over pressure air will cause malfunctions, including delayed starting.

AREA EQUIPMENT

Secure work. Whenever possible use clamps, vises, chains and straps to secure pipe.

Make sure the tool is secured; it is safer to have both hands free to operate the tool.

TOOL USE

Use the right tool and tool bit for the job. Do not use a tool, which is incorrect for the job you are doing.

Keep the tool bits fully engaged in the tool bit holders. Loose bits are a safety hazard.

Disconnect power supply during setup and maintenance. Use all 'Stop' or Shut off' features available when changing or adjusting tool bits, maintaining the tool, or when the tool is not in use.

Remove adjusting keys and wrenches before applying power to the equipment. Develop a habit of checking the tool before turning it on to make sure that all keys and wrenches have been removed.

Do not force tools. Tools and tool bits function better and safer when used at the feed and speed rate for which they were designed.

Do not reach into rotating equipment. Do not reach into the rotating head stock to clear chips, to make adjustments, or to check surface finish. A machine designed to cut steel will not stop for a hand or an arm.

Handle chips with care. Chips have very sharp edges and are hot. Do not try to pull chips apart with are hands; they are very tough.

Avoid unintentional starts. Do not carry or handle tools with your hand on the operating switches or levers. Do not lay the tool down in a manner that will start the drive. Do not allow the tool to flip around or move when adjusting or changing tool bits.

Store idle tools properly. Disconnect tools from the power source and store in a safe place. Remove tool bits for safe handling of the tool.

SPECIFICATIONS

The Model 300 MICROFACER™ Tube Squaring Tool has been developed to square the ends of up to .75" (19.0 mm) OD tubing.

Weight:

5.35" (2.4 Kg)

Envelope Drawing

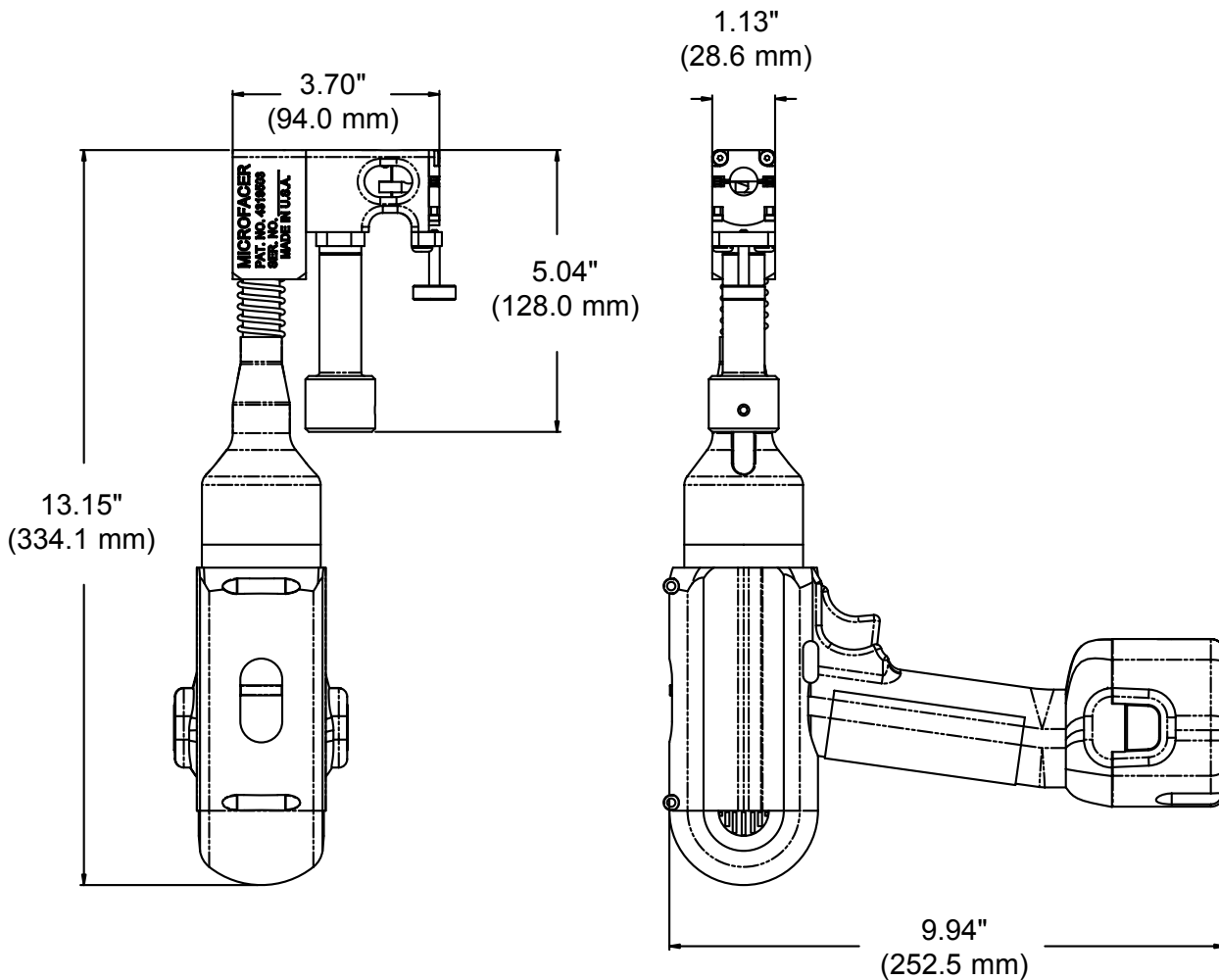

MAINTENANCE

All components should be cleaned and coated with a light film of oil prior to use.

Use a clean, non-detergent oil, preferably SAE 10 (90 SSU) or lighter.

When the Model 300 is operated in the vertical position, cutting head up, it should be turned upside down and the chips and/or other debris removed after each tube squaring operation has been completed.

NOTE:

Tool life may be severely shortened, unless chips and/or other debris that have been deposited on the cutting head during the machining operation are removed.

OPERATION

Read the Operating Instructions carefully before attempting to operate the Model 300 MIROFACER™ Tube Squaring Tool.

Use eye protection at all times when operating Model 300.

INSTALLING THE SADDLE SET

Select the saddle set which is the proper size for the OD of the tube which is to be machined.

Squeeze the saddle set to compress the springs and insert the saddle set into the front of the Model 300.

Retain the saddle set by inserting the two (2) cap screws into the front of the saddle set.

INSTALLING THE TOOL BIT

Select the tool bit to be installed.

Slide the tool bit into the slot on front of the main shaft.

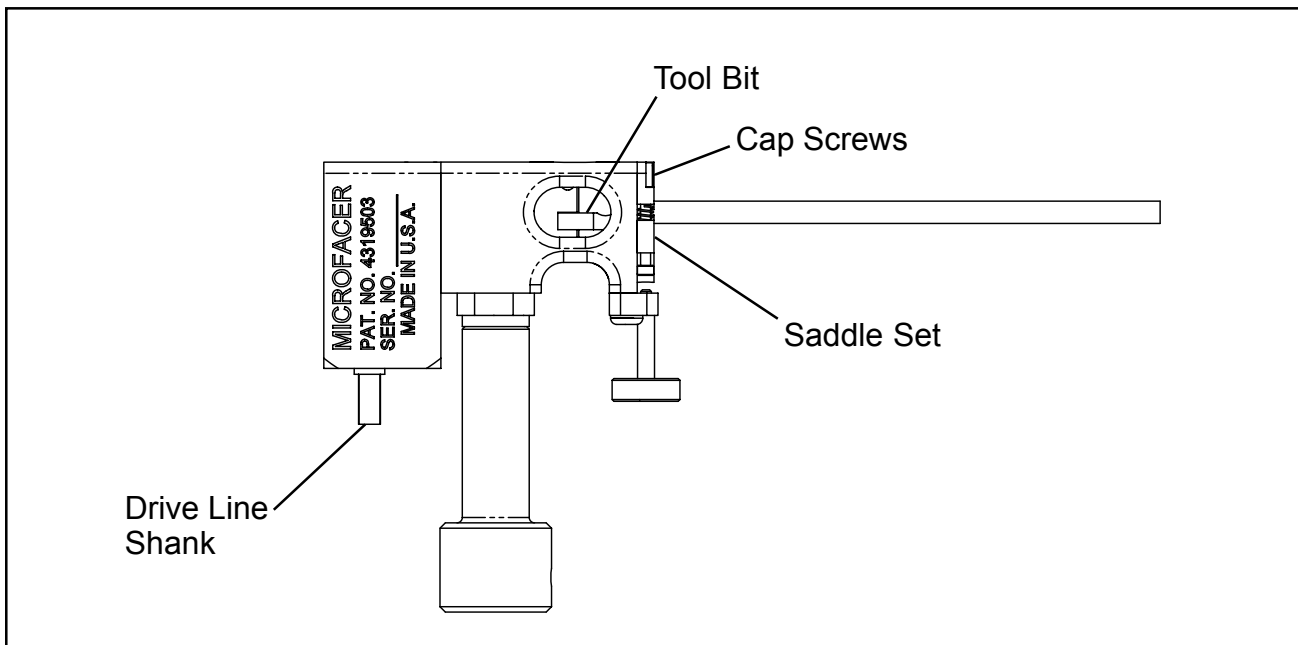

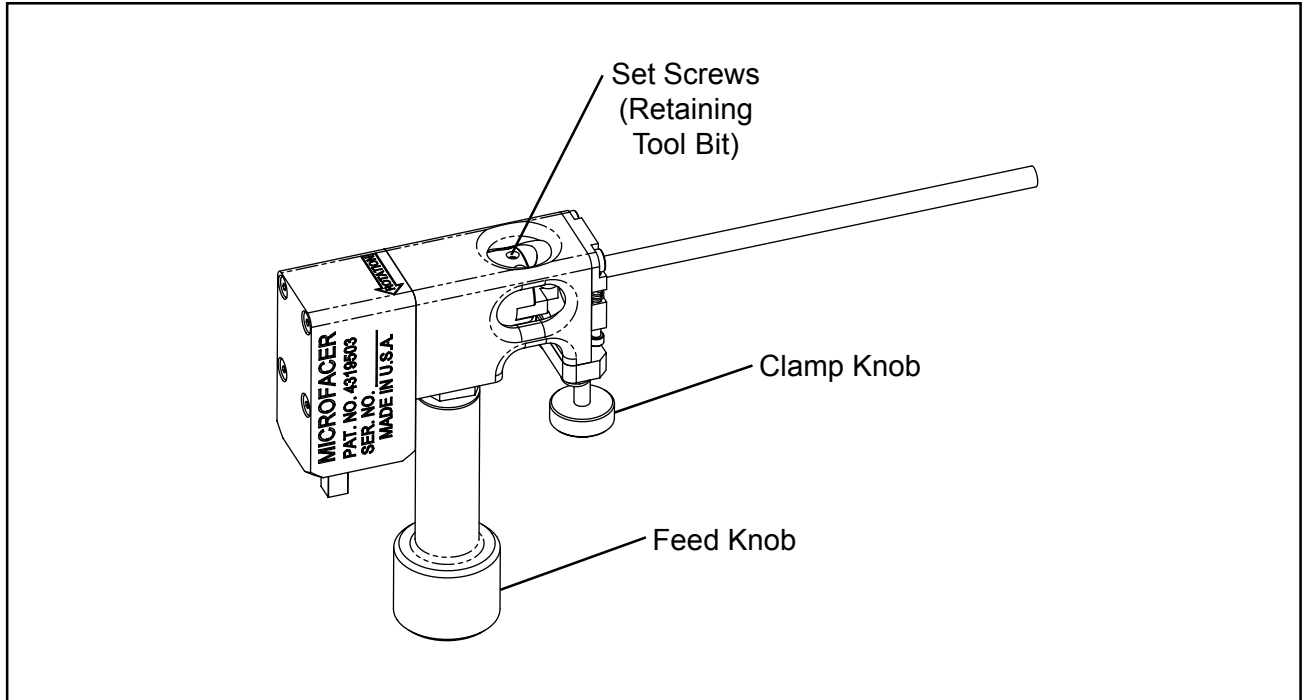

INSTALLATION

Slide the tube to be worked on into the saddle, leaving approximately 1/8" (3 mm) between the tool bit and the end of the tube.

INSERT IMAGE

Tighten the saddle set by turning the clamp knob below the saddle set.

MACHINING SEQUENCE

Turn the motor on and let it slowly rotate to ensure that the tool bit does not make contact with the end of the tube at this time.

Loosen the clamp knob to release the saddle set and remove the machined tube.

CUTTING SPEEDS AND FEEDS

True DIA		RPM for 200 in/min (5080 mm/min)	RPM for 250 in/min (6350 mm/min)	RPM for 300 in/min (7620 mm/min)
.125"	3.18 mm	509	636	763
.250"	6.35 mm	255	318	382
.375"	9.53 mm	170	212	255
.500"	12.70 mm	127	159	191
.625"	15.88 mm	102	127	153
.750"	19.05 mm	85	106	127
Cutting Speed (Approximately)				

Use 200 surface inches per minute (5080 surface millimeters per minute) for:

Stainless steels in general when no coolant is allowed, all heavy-wall tube and some chrome/molybdenum steels.

Use 250 surface inches per minute (6350 surface millimeters per minute) for:

Mild steels and some thin-wall stainless steels when coolants are permitted and applied.

Use 300 surface inches per minute (7620 surface millimeters per minute) for:

Aluminum and some thin-wall mild steel and tube with coolants.

BASIC FEED RECOMMENDATION

Use very light feed for initial beveling or until a continuous cut is established.

This is very important for longer tool bit life when cutting through flame cut or out of square pipe ends.

Use adequate feed, .003" to .006" (.08mm to .15mm) per revolution thereafter, to establish a continuous chip cut.

If the feed is too light, only light stringer chips will be removed.

If the feed is too heavy the drive will start to overload and the chip will start to have a rough or torn appearance.

SADDLE SETS

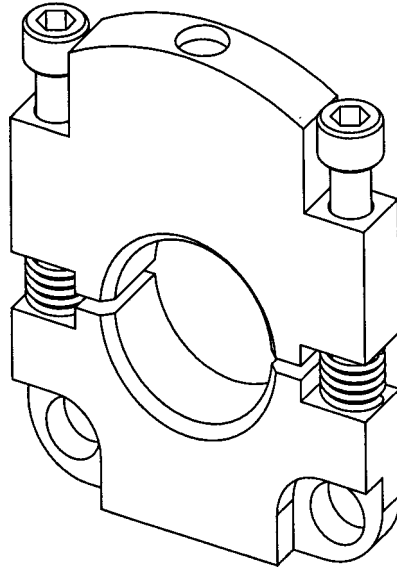

Pipe Size	Fraction	Decimal	Metric	Saddle P/N
	1/8"	.125"	3.18 mm	67-4193
	5/32"	.156"	3.96 mm	67-4194
		.158"	4.00 mm	67-4195
	3/16"	.188"	4.76 mm	67-4196
		.197"	5.00 mm	67-4197
	7/32"	.219"	5.56 mm	67-4198
		.234"	5.95 mm	67-4199
		.236"	6.00 mm	67-4200
	1/4"	.250"	6.35 mm	67-4201
		.276"	7.00 mm	67-4202
	9/32"	.281"	7.14 mm	67-4203
		.283"	7.20 mm	67-4204
	5/16"	.313"	7.95 mm	67-4205

Model 300 MICROFACER™

Pipe Size	Fraction	Decimal	Metric	Saddle P/N
		.315"	8.00 mm	67-4206
	11/32"	.344"	8.74 mm	67-4207
		.354"	9.00 mm	67-4208
		.359"	9.13 mm	67-4209
	3/8"	.375"	9.53 mm	67-4210
		.394"	10.00 mm	67-4211
		.400"	10.16 mm	67-4212
1/8"	13/32"	.406"	10.31 mm	67-4213
		.413"	10.50 mm	67-4214
		.422"	10.72 mm	67-4215
		.433"	11.00 mm	67-4216
	7/16"	.438"	11.13 mm	67-4217
	15.32"	.469"	11.91 mm	67-4218
		.472"	12.00 mm	67-4219
	1/2"	.500"	12.70 mm	67-4220
		.512"	13.00 mm	67-4221
		.531"	13.50 mm	67-4222
		.535"	13.60 mm	67-4223
1/4"		.540"	13.72 mm	67-4224
		.543"	13.80 mm	67-4225
		.547"	13.89 mm	67-4226
		.551"	14.00 mm	67-4227
	9/16"	.563"	14.30 mm	67-4228
		.591"	15.00 mm	67-4229
		.594"	15.08 mm	67-4230
		.602"	15.29 mm	67-4231
	5/8"	.625"	15.88 mm	67-4232

TRI TOOL INC.

Pipe Size	Fraction	Decimal	Metric	Saddle P/N
		.630"	16.00 mm	67-4233
		.641"	16.27 mm	67-4234
		.656"	16.66 mm	67-4235
		.669"	17.00 mm	67-4236
3/8"		.675"	17.15 mm	67-4237
		.677"	17.20 mm	67-4238
		.681"	17.30 mm	67-4239
	11/16"	.688"	17.48 mm	67-4240
		.709"	18.00 mm	67-4241
		.718"	18.24 mm	67-4242
	3/4"	.750"	19.05 mm	67-4243

TOOL BITS

Tool Bit, Tube Squaring, P/N 99-0591

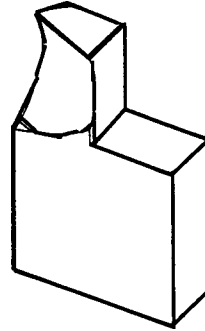

TROUBLE SHOOTING

Problem: The Tool Bit Chatters

The tool bit is loose or overextended.
The tool bit is damaged.
The tool holder is too loose in the slides.
The cutting speed is too fast.
The clamping pads are loose on the pipe or tube.
Cutting fluid is required.
The main bearing pre-load is loose.

Problem: There is excessive Tool Bit wear

The pipe or tube material is too hard or abrasive.
The cutting speed is too fast.
Cutting fluid is required.
A dull Tool Bit is causing surface hardening conditions (Stainless pipe or tubing).
There is scale or other foreign matter on the pipe or tube, which is dulling the tool bit at the start of the cut.
The tool bit is incorrect for the material being cut.

Problem: The surface finish is rough

The tool bit is dull, chipped, etc.
Metal build-up on the cutting edge of the tool bit is creating a false cutting edge.
Cutting fluid is required.

Problem: There is a loss of air power

The air supply pressure is too low.
The air filter is plugged.
The air line size is insufficient.
The air line is too long.

Problem: The tool bit will not reach the work

Incorrect tool blocks are installed for the size of the pipe or tube being worked on.

Incorrect tool bit is installed.

ACCESSORIES

The following accessories are recommended for use with the Model 300 MICROFACER and are available from TRI TOOL INC.

1. Flexible Shaft Assembly (18") - P/N 14-0036
2. Spare Battery, 9.6V - P/N 30-3131
3. Charger, 220V, 7.2V - 18V Dewalt - P/N 30-2614
4. Charger, 110V, 7.2V - 18V Dewalt - P/N 30-2615

A Filter/Regulator/Lubricator (FRL) is required to protect the warranty on all TRI TOOL INC. air driven tools.

ILLUSTRATED PARTS BREAKDOWN

MODEL 300 MICROFACER™ BODY ASSEMBLY (P/N 02-2297)

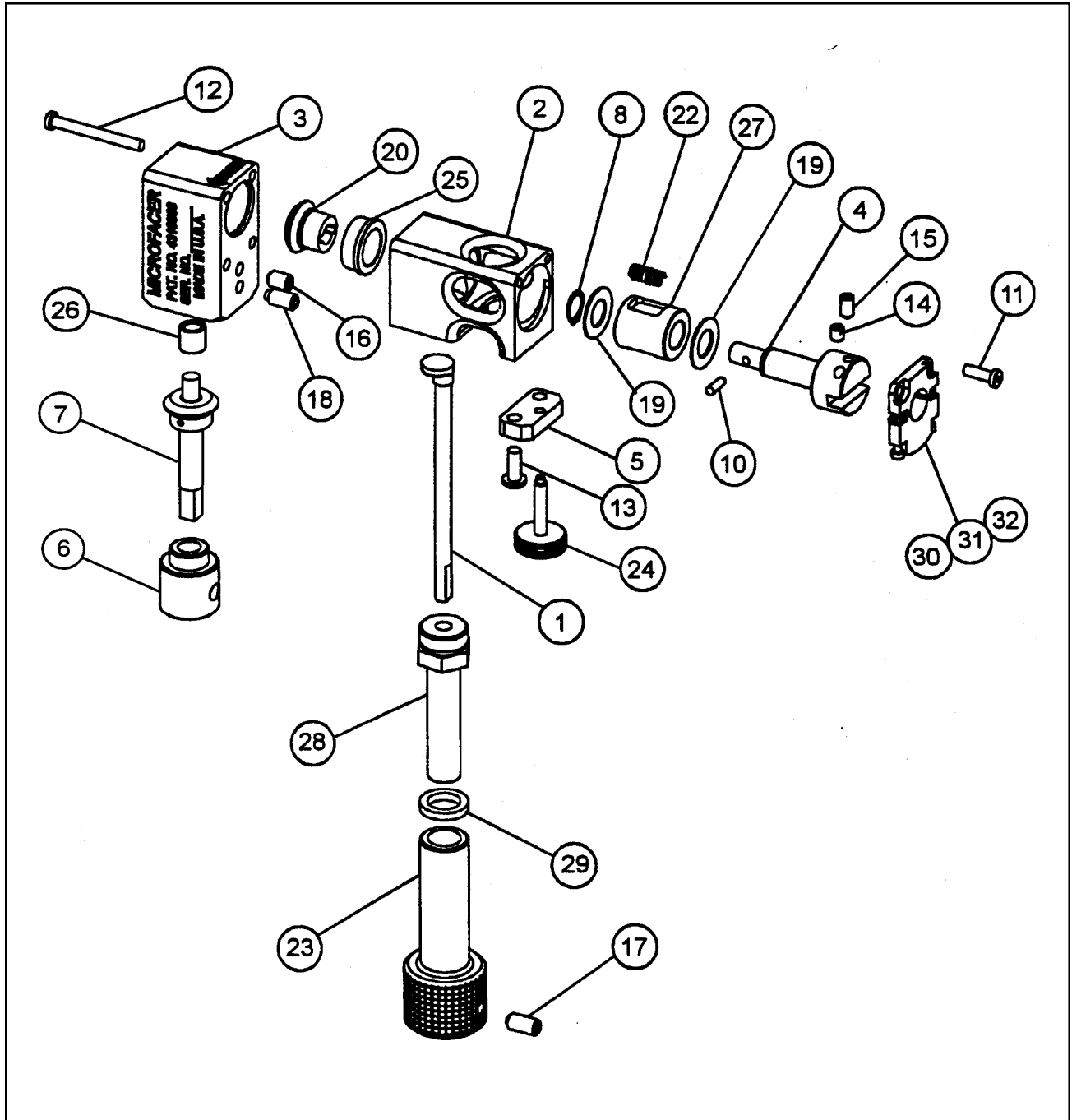

TRI TOOL INC.

Parts List, Model 300 MICROFACER™ Body Assembly (P/N 02-2297)

Item No.	Part No.	Description	Qty
1.	14-0006	SHAFT ASSEMBLY	1
2.	19-0838	HOUSING, MAIN	1
3.	19-0796	HOUSING, DRIVE	1
4.	20-0718	SHAFT, MAIN	1
5.	24-1614	PLATE, CLAMP	1
6.	27-0584	ADAPTER, DRIVE BUSHING	1
7.	27-0725	ADAPTER ASSEMBLY, CABLE DRIVE	1
8.	30-0302	RING, RETAINING, EXTERNAL	1
10.	32-0514	PIN, DRIVE, 1/8" DIA	1
11.	33-2110	SCREW, CAP, #8-32 X 1/2"	2
12.	33-2121	SCREW, CAP, #8-32 X 1 1/2"	4
13.	33-2112	SCREW, BUTTON, #10-24 X 1/2"	2
14.	33-0488	SET SCREW, CUP PT, #10-24 X 1/4"	2
15.	33-0490	SET SCREW, CUP PT., #10-24 X 3/8"	1
16.	33-0501	SET SCREW, CUP PT., 1/4-20 X 3/8"	1
17.	33-0503	SET SCREW, CUP PT., 1/4-20 X 1/2"	1
18.	33-0927	SET SCREW, HALF DOG, 1/4-20 X 1/2"	1
19.	34-0351	WASHER, THRUST	2
20.	39-0828	GEAR, BEVEL, MAIN	1
22.	40-0236	SPRING, COMPRESSION	1
23.	42-0174	HANDLE	1
24.	42-0175	KNOB, SADDLE ADJUST	1
25.	45-0306	BUSHING, MAIN	1
26.	45-0296	BUSHING, BRONZE	
27.	46-0462	SLEEVE, MAIN	1
28.	46-0479	SLEEVE	1
29.	34-0060	WASHER	1
30.	67-XXXX	SADDLE SET	REF.
31.	33-2109	SCREW, CAP, #4-40 X 7/8"	REF.
32.	40-0236	SPRING, COMPRESSION	REF.

Parts List, Model 300 MICROFACER™ Body Assembly (P/N 02-2297) Con't.

Item No.	Part No.	Description	Qty
NOT SHOWN			
	36-0002	WRENCH, L, 5/64" HEX	1
	36-0003	WRENCH, L, 3/32" HEX	1
	36-0016	WRENCH, T, 3/32" HEX	1

300MF MOTOR ASSEMBLY (P/N 58-0164)

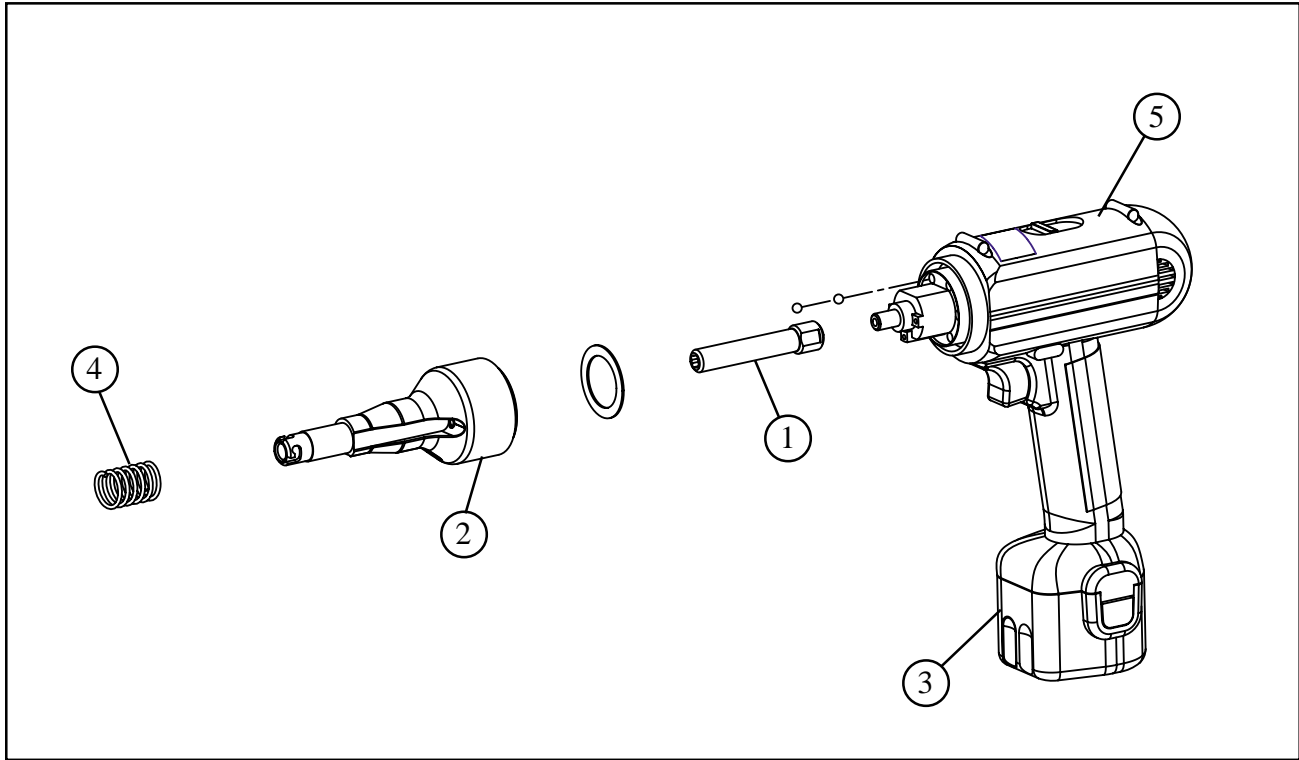

Parts List, 300MF Motor Assembly (P/N 58-0164)

Item No.	Part No.	Description	Qty
1.	20-0911	SHAFT, DRIVE	1
2.	27-0818	ADAPTER, BAYONET	1
3.	30-3131	BATTERY, 9.6V	1
4.	40-0143	SPRING, MUSIC WIRE, LC-085K-3	1
5.	58-0193	MOTOR, ELECTRIC, 9.6V, MOD.	1

DEWALT SAFETY INSTRUCTIONS

The DeWALT Cordless Drill/Driver comes with an 'Instruction Manual' and should be referenced for all safety and operating procedures.