

### TABLE OF CONTENTS

CUSTOMER MESSAGE	Inside Front Cover
SAFETY PRECAUTIONS	3
GENERAL DESCRIPTION	6
SPECIFICATIONS	7
MAINTENANCE	8
STANDARD JACKSCREW AND SPACERS, AND EXTENSION KIT	10
OPERATION	11
DISASSEMBLY AND ASSEMBLY	18
TROUBLE SHOOTING	19
ILLUSTRATED PARTS BREAKDOWN	20
TOOL BIT RESHARPENING POLICY	Inside Back Cover
WARRANTY INFORMATION	Inside Back Cover

Copyright 2008  
Proprietary property of TRI TOOL Inc.  
No reproduction, use, or duplication of the information  
shown hereon is permitted without the express written  
consent of TRI TOOL Inc.

## SAFETY PRECAUTIONS

### IN GENERAL

When using rotating head cutting equipment, basic safety precautions should always be followed to reduce the risk of personal injury.

Operate this tool only in accordance with specific operating instructions.

#### **WARNING:**

Do not override the deadman switch on the power unit. Locking down, obstructing, or in any way defeating the deadman switch on the power drive unit may result in serious injury.

### DRESS CONSIDERATIONS

Use standard safety equipment. Hard hats, safety shoes, safety harnesses, protective clothes, and other safety devices should always be used when appropriate.

Use safety glasses. Do not operate cutting tools without eye protection.

Dress properly. Do not wear loose clothing or jewelry. They can be caught in rotating and moving parts. Avoid slippery floors or wear nonskid footwear. If you have long hair, wear protective hair covering to contain it.

### WORK AREA

Keep the work area clean. Cluttered work areas and benches invite injuries.

Consider the work area environment. Keep the area well lit. Keep electrical cords, cables, rags, rigging straps, and etc. clear of rotating equipment. Do not use power-cutting tools in the presence of flammable liquids and gasses.

Keep visitors away. Do not let visitors or untrained personnel at or near operating tools. Enforce eye protection requirements for all observers.

Do not over reach. Keep proper footing at all times.

Stay alert. Watch what you are doing. Use common sense. Do not operate tools when you are tired.

### TOOL CARE

Maintain tools with care. Keep tools in good operating condition. Sharp tool bits perform better and safer than dull tool bits. Well maintained tools function properly when needed.

Check for damaged parts. If a tool has malfunctioned, been dropped or hit, it must be checked for damage. Run no-load tests and feed function checks. Do a complete visual inspection.

Electric motors. Use only with proper AC voltage power sources and observe all normal electric shock hazard procedures.

Do not abuse power and control cords. Pulling or running over cords and cables can result in electrical shock hazards and malfunctions. Keep control and power cords out of all cutting fluids and water.

Hydraulic drives. Observe proper procedures for electrically driven power sources. Avoid damage to hydraulic lines. Keep quick-disconnects clean. Grit contamination causes malfunctions.

Air tools. Check the exhaust muffler. Broken or damaged mufflers can restrict air flow or cause excessive noise. Use air motors only with a filtered, lubricated and regulated air supply. Dirty air, low-pressure air or over pressure air will cause malfunctions, including delayed starting.

### AREA EQUIPMENT

Secure work. Whenever possible use clamps, vises, chains and straps to secure pipe.

Make sure the tool is secured; it is safer to have both hands free to operate the tool.

### TOOL USE

Use the right tool and tool bit for the job. Do not use a tool, which is incorrect for the job you are doing.

Keep the tool bits fully engaged in the tool bit holders. Loose bits are a safety hazard.

Disconnect power supply during setup and maintenance. Use all 'Stop' or Shut off' features available when changing or adjusting tool bits, maintaining the tool, or when the tool is not in use.

Remove adjusting keys and wrenches before applying power to the equipment. Develop a habit of checking the tool before turning it on to make sure that all keys and wrenches have been removed.

Do not force tools. Tools and tool bits function better and safer when used at the feed and speed rate for which they were designed.

Do not reach into rotating equipment. Do not reach into the rotating head stock to clear chips, to make adjustments, or to check surface finish. A machine designed to cut steel will not stop for a hand or an arm.

Handle chips with care. Chips have very sharp edges and are hot. Do not try to pull chips apart with are hands; they are very tough.

Avoid unintentional starts. Do not carry or handle tools with your hand on the operating switches or levers. Do not lay the tool down in a manner that will start the drive. Do not allow the tool to flip around or move when adjusting or changing tool bits.

Store idle tools properly. Disconnect tools from the power source and store in a safe place. Remove tool bits for safe handling of the tool.

## GENERAL DESCRIPTION

The Model 236B Miter Mandrel Head is an accessory option that is used to expand the versatility of the Model 236B BEVELMASTER™ by allowing in-situ setup on irregular pipe, fittings, and valves.

The Miter Mandrel Head is secured to the ID of the workpiece using eight (8) individually adjusted jackscrews in two (2) separate rows.

Once secure, two (2) distinct types of adjustments are easily performed: Angular Offset and Parallel Offset.

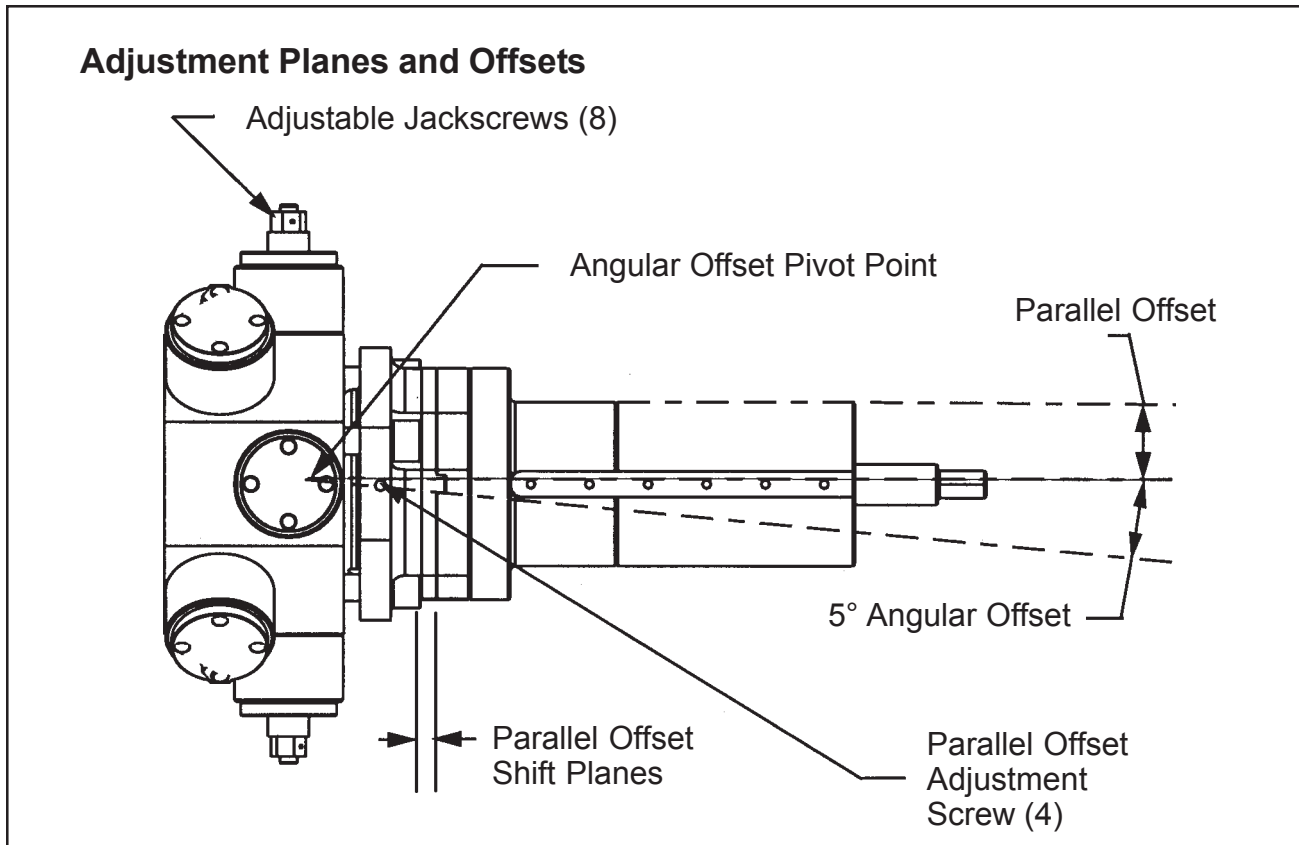

With the Angular Offset Adjustment, the Mandrel Shaft can be precisely aligned with the workpiece even though the ID of the workpiece might be irregular or it may be adjusted up to 5° from the centerline in any direction desired to give a mitered prep.

The parallel Offset Adjustment accurately re-centers the Mandrel Shaft after the angular offset adjustment has been made.

Both adjustments are accomplished with the aid of an 'Indicating Sleeve' and Dial Indicator Kit.

# SPECIFICATIONS

Weight: 250 (113.4 kg) Weight will vary with the jackscrew size.

Pipe Holding Capacities (Standard Machine)

Basic Pipe Sizes

16" pipe	Schedules 5 through 80
18" pipe through 36" pipe	All schedules

Inside DIA Mounting Range

14.00" (355.6 mm) through 36.75" (933.4 mm)

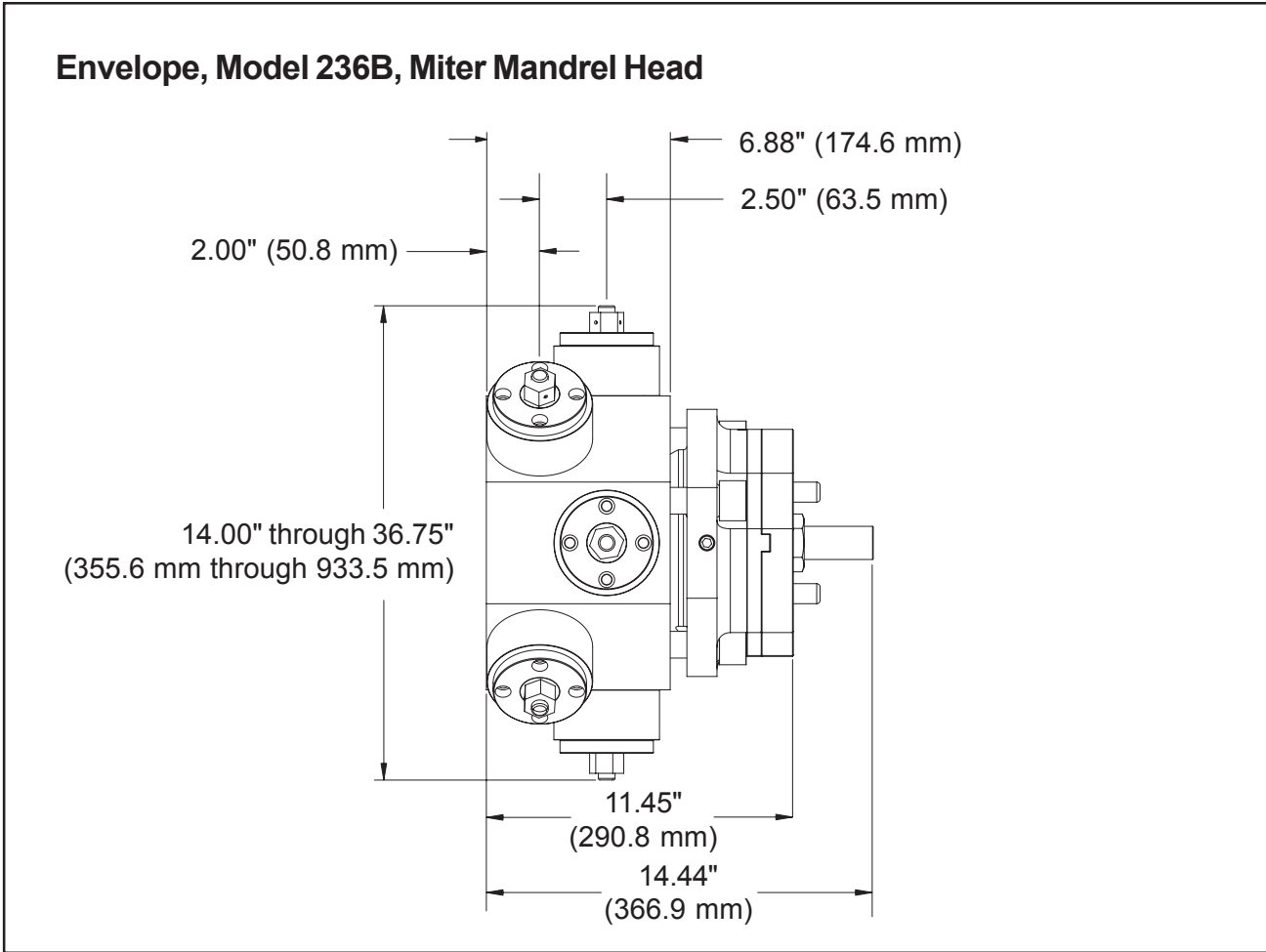

## MAINTENANCE

Tri Tool Miter Mandrel Heads are precision tools that will perform excellently if they are well maintained.

All components should be cleaned and coated with a light film of oil prior to use.

Tool life may be severely shortened, unless chips and/or other debris that has been deposited on or around the Headstock during the machining operation are removed.

Daily maintenance should include a visual inspection of all parts for damage due to chips, impact or improper use.

Repair or replace broken or damaged parts as necessary.

Wipe the machine clean of cutting fluids, dirt and grime, coat with a light film of oil.

### Identification of Various Major Parts

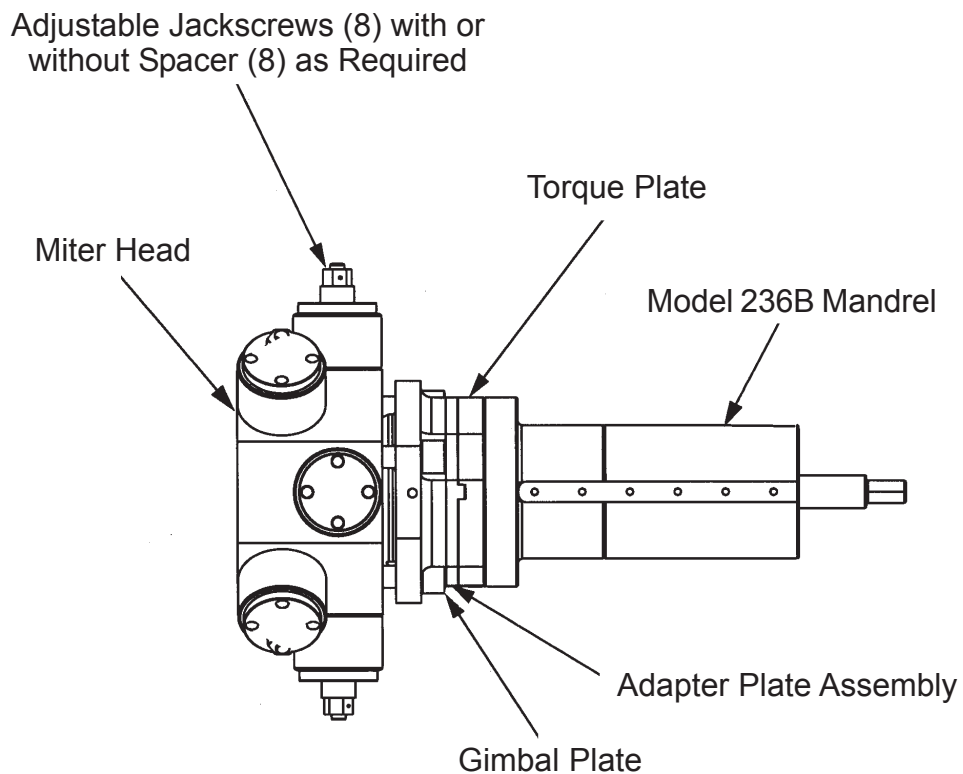

Weekly maintenance should include checking the mandrel, wiping the oil and grime from the surface and then relubricating it with a light film of oil.

Occasionally back off the four (4) parallel offset adjustment screws, remove the Draw Nut, Adapter Plate Assembly and the Torque Plate.

Check all parts for cracks, burrs, etc.

Remove the four (4) Angular Offset Adjustment Screws and Spherical Washers and separate the Gimbal Plate from the Mandrel Head.

Check the spherical bearing surface for burrs and/or other defects.

Do not reuse any part that shows evidence of cracking, bending or over stressing.

Apply a very thin coat of general purpose grease or anti-seize to the spherical surface of the gimbal plate, two (2) or three (3) drops of light oil on each of the four (4) spherical washers, apply grease or anti-seize to both sides of the torque plate and grease, anti-seize or oil to all screws, nuts and threads. Reassemble in the reverse order of disassembly.

## STANDARD JACKSCREW AND SPACERS

Jackscrew P/N	Spacer P/N	Length	Range	
33-1251	---	---	14.00" (356 mm)	17.75" (450.8 mm)
	44-1043	1.875"	17.75" (450.8 mm)	22.50" (571.5 mm)
	44-1044	4.250"	22.50" (571.5 mm)	27.25" (698.5 mm)
	44-1045	6.625"	27.25" (698.5 mm)	32.00" (812.8 mm)
	44-1046	9.000"	32.00" (812.8 mm)	36.75" (933.4 mm)

## EXTENSION KIT

Spacer Extension P/N	Jackscrew P/N	Standard Spacer P/N	Length	Range	
44-1048	33-1251	---	11.375"	36.75" (933.4 mm)	41.50" (1054.1 mm)
		44-1043	13.750"*	41.50" (1054.1 mm)	46.25" (1174.7 mm)
		44-1044	16.125"*	46.25" (1174.7 mm)	51.00" (1295.4 mm)
		44-1045	18.500"*	51.00" (1295.4 mm)	55.75" (1416.0 mm)
		44-1046	20.875"*	55.75" (1416.0 mm)	60.50" (1536.7 mm)

\*Spacer Extension and Standard Spacer Combined.

## OPERATION

**CAUTION:** Never attempt to manually lift the Mandrel with the 236B installed.

The eight (8) Jackscrews are removable.

They are made of heat treated steel and have a slight spherical radius on the surface that contacts the workpiece.

On most surfaces this provides for excellent holding power with virtually no marring of the workpiece.

One (1) length of jackscrews and four (4) lengths of spacers are provided.

Before the Miter Mandrel Head is mounted to the workpiece, both the Angular Offset and the Parallel Offset Adjustments should be approximately centered.

This will permit a maximum range of adjustment for final settings after the mandrel has been mounted.

By turning the Draw Rod counterclockwise, remove the Mandrel Shaft Assembly from the Miter Head.

**NOTE:** To make the Parallel Offset Adjustment, all four (4) screws must be slightly loose.

Install the Mandrel Shaft Assembly onto the Adapter Plate Assembly and tighten the draw rod to 250 ft/lbs (339 Nm) to 300 ft/lbs (407 Nm).

At this time, the Miter mandrel should feel absolutely tight and rigid.

Before installing the 236B BEVELMASTER™ be sure to read the Operator's manual carefully, giving special attention to all safety cautions and warnings.

Check the gap between the Gimbal Plate and the Mandrel Head to see that it is approximately even all around.

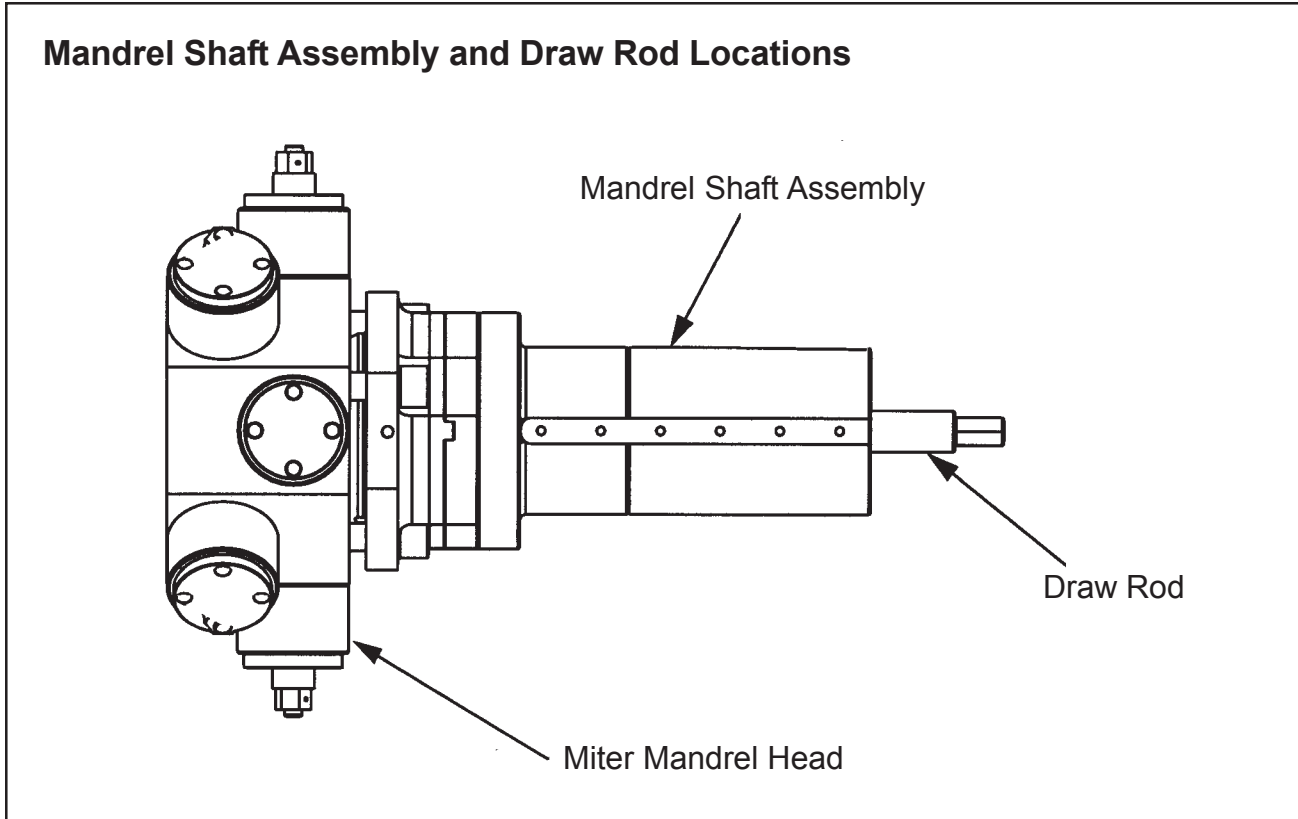

If it is not then loosen the angular offset adjustment screw(s) where the gap is small and tighten the Angular Offset Adjustment Screw(s) where the gap is wide.

Lightly tighten the Draw Nut.

**NOTE:** All four (4) of the Angular Offset Adjustment Screws must be used in conjunction with each other.

All screws must be at least slightly loose to allow movement.

If the Mandrel Shaft is to be drawn directly toward one screw, the opposite screw must be loosened far enough to allow for the take up before the near screw is tightened.

Leave the Draw Nut slightly loose during and after the Angular Offset adjustment.

Check to see that the Adapter Plate Assembly is centered to the gimbal plate.

If not, locate the four (4) parallel offset adjustment screws and back off one (1) or two (2) screws where the Adapter Plate Assembly is 'in'.

Angular Offset Adjustment

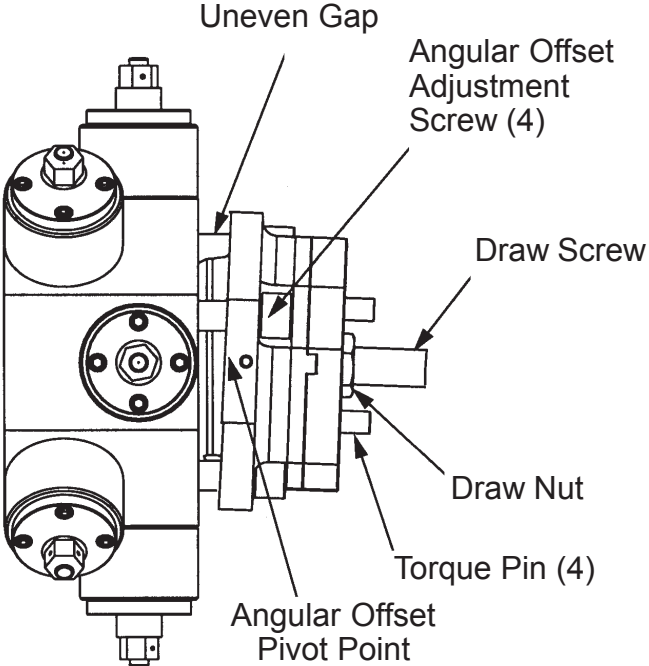

Parallel Offset Adjustment

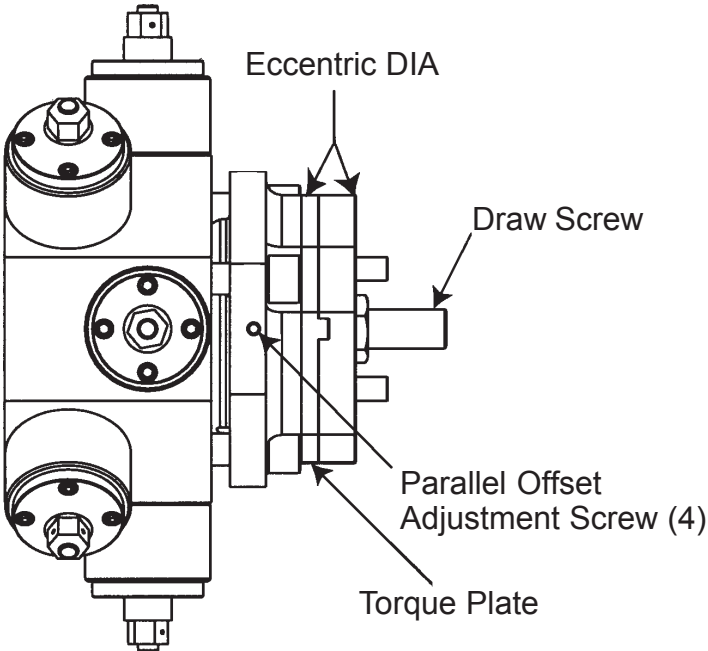

Tightening to the opposite one (1) or two (2) screws will bring the Adapter Plate Assembly toward the center.

**NOTE:** To make the Parallel Offset adjustment, all four (4) screws must be slightly loose.

Once the Adapter Plate Assembly has been roughly aligned and centered, temporarily snug all of the Adjustment Screws and the Draw Nut.

Insert the Miter Head into the workpiece.

**NOTE:** It is highly desirable to mount the Miter Head so that the Angular Offset Pivot point is on the same plane with the proposed finished wall preparation.

This will diminish the amount of parallel offset required after the angular adjustment has been made.

Using a tape measure or steel rule, keep the rear flange of the Gimbal Plate roughly centered while turning the Jackscrews to tighten them against the ID of the workpiece.

Use the wrenches provided to tighten all eight (8) Jackscrews securely.

### Installation of the Indicator Sleeve Assembly

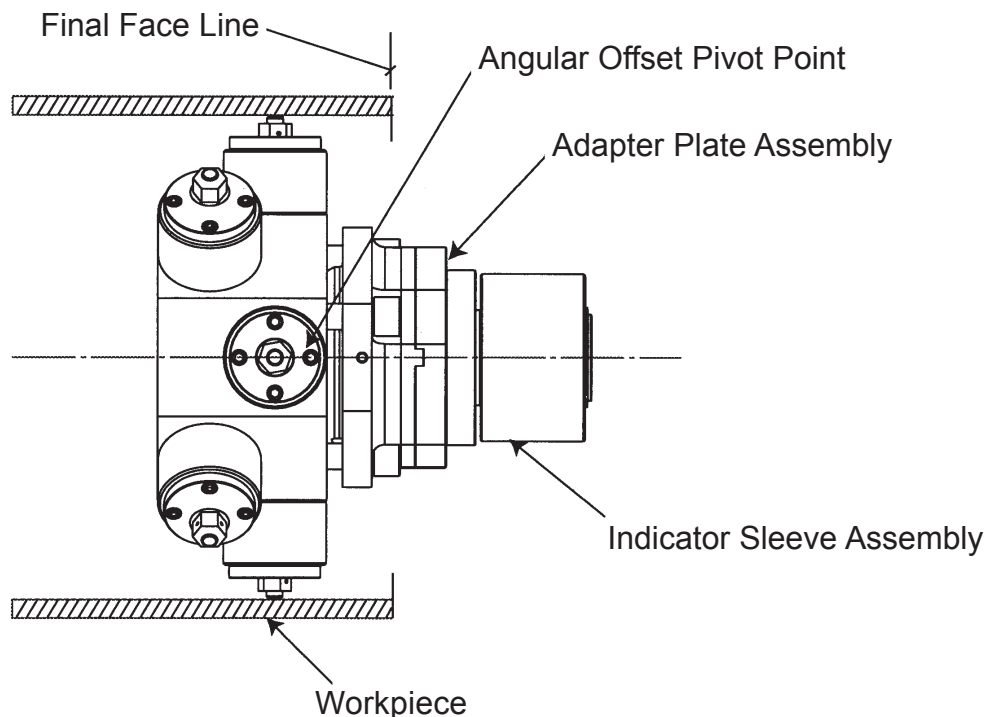

Mount the Indicator Sleeve to the Adapter Plate Assembly and tighten the Mounting Nut.

Place the Magnetic Based Indicator Holder onto the Sleeve and energize the magnet.

If the existing surface of the workpiece is to be used for alignment and centering references, use the Dial Indicator and hardware provided.

If punch marks, scribe lines or other references are to be used, simply select the required hardware from the Indicator Kit to be used as a pointer.

The first adjustment to be made after mounting is always the angular offset.

**NOTE:** Changing the Angular Offset will always change the Parallel Offset, but changing the Parallel Offset will not change the Angular Offset.

**Dial Indicator Kit Setup**

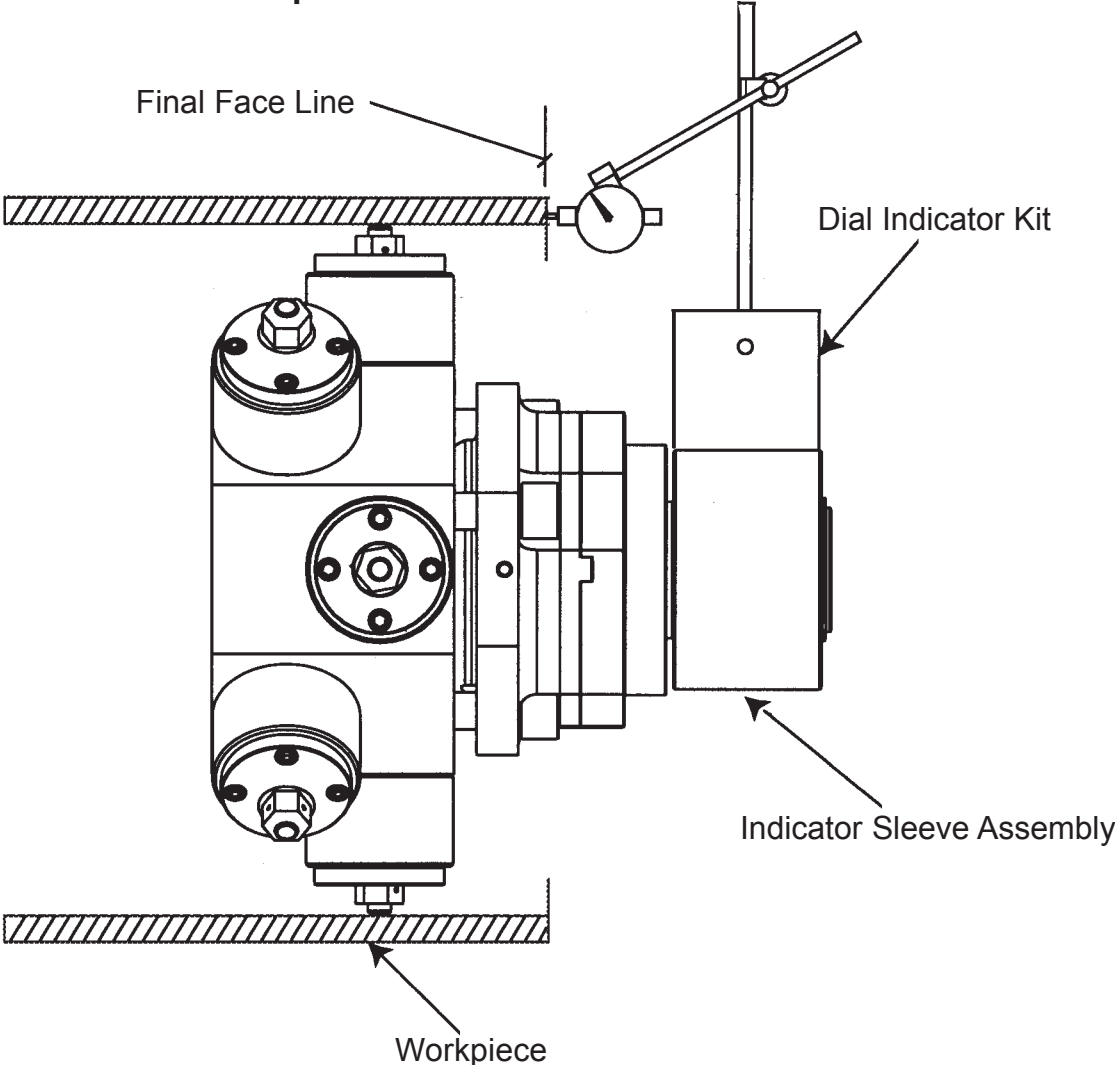

To move the Adapter Plate Assembly in a given direction, one (1) or two (2) Angular Offset Adjustment Screw(s) opposite the direction of the movement must be loosened enough to allow the amount of movement anticipated.

Then the screw(s) directly across must be retightened to draw the Adapter Plate Assembly in the desired direction.

**NOTE:**

Never exceed 80 ft/lbs (109 Nm) of torque on the Angular Offset Adjustment Screws.

Repeat the indicating procedure and Angular Offset procedure as many times as necessary to achieve the accuracy desired.

Evenly tighten four (4) Angular Offset Adjustment Screws.

Now the Parallel Offset Adjustment may be made.

As before, use the Indicator Kit to determine how much the Adapter Plate Assembly must move, and in what direction.

To move the Adapter Plate Assembly in a given direction, first loosen one (1) or two (2) Parallel Offset Adjustment Screw(s) on the side of the Adapter Plate Assembly, that you wish to move toward.

Now tighten the screw (s) on the side of the Adapter Plate Assembly which you wish to move away from in order to push the Adapter Plate Assembly in a given direction.

Never exceed 60 ft/lbs (82 Nm) of torque on the Parallel Offset Adjustment Screws.

Repeat the indicating procedure and the Parallel Offset adjusting procedure as many times as necessary to achieve the accuracy desired.

Once the accuracy requirements have been satisfied, evenly tighten all four (4) Parallel Offset Adjustment Screws.

Recheck the adjustment with the indicator sleeve.

Remove the indicator items and the Indicator Sleeve from the Miter Head.

Tighten the Draw Nut securely.

Torque should be 100 ft/lbs (136 Nm) to 130 ft/lbs (229 Nm).

Align the torque pin holes in the end of the Mandrel Shaft with the torque pins in the Adapter Plate Assembly.

Install the Mandrel Shaft Assembly onto the Adapter Plate Assembly and tighten the Draw Rod to 250 ft/lbs (339 Nm) to 300 ft/lbs (407 Nm).

At this time, the Miter Mandrel should feel absolutely tight and rigid.

Before installing the 236B BEVELMASTER™ be sure to read the Operator's manual carefully, giving special attention to all safety cautions and warnings.

## DISASSEMBLY AND ASSEMBLY

Back off the four (4) Parallel Offset Adjusting Screws about three full turns each.

Unscrew the Draw Rod and slide the Mandrel Shaft Assembly rearward.

Remove the Draw Nut, the Adapter Plate Assembly and the Torque Plate.

Remove the four (4) Angular Offset Adjustment Screws and the four (4) Spherical Bearings.

Remove the Gimbal Plate.

Remove the Jackscrews and Spacers from the Head Assembly.

Assembly is done in reverse order of disassembly.

## TROUBLE SHOOTING

**Problem: There is a loss of air power**

The air supply pressure is too low.  
The air filter is plugged.  
The air line size is insufficient.  
The air line is too long.

**Problem: There is a loss of hydraulic power**

The hydraulic supply pressure is too low.  
The hydraulic filter is plugged.  
The hydraulic line size is insufficient.  
The hydraulic line is too long.

**Problem: The air motor will not start**

The air power supply is shut off.  
The air motor is damaged and will not run free. The air motor needs lubrication.  
Add lubrication and do not run the air motor for a few minutes, then try running the motor. Tap on the side of the air motor casing lightly with a piece of wood or with a soft rubber mallet just in case the vanes may be sticking.

**Problem: The hydraulic motor will not start**

The hydraulic power supply is shut off.  
The hydraulic motor is damaged and will not run free.

# ILLUSTRATED PARTS BREAKDOWN

## MODEL 236B MITER MANDREL ASSEMBLY

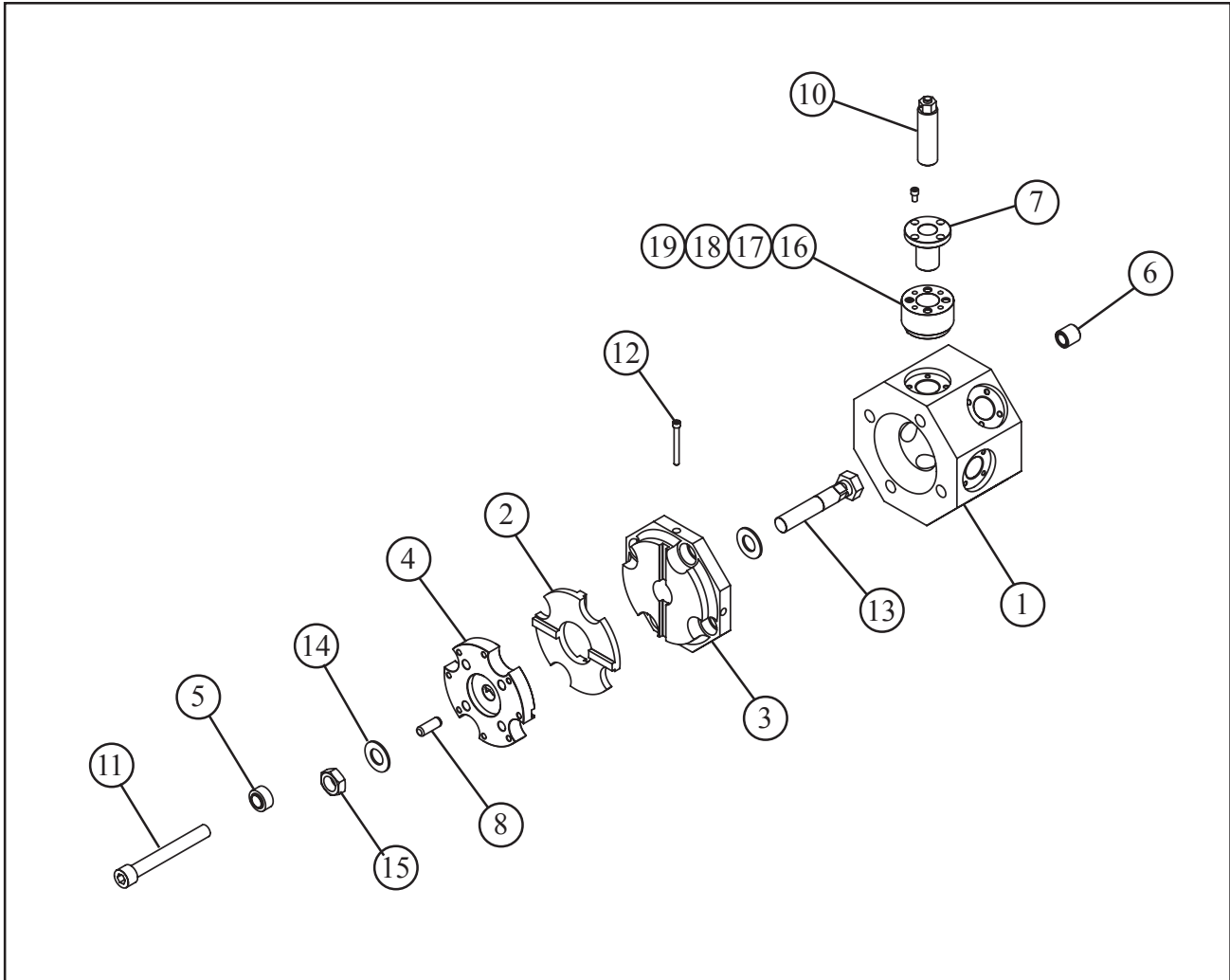

Parts List, Model 236B Miter Mandrel Assembly

Item No.	Part No.	Description	Qty
	06-0207	MITER MANDREL ASSEMBLY, 236B	1
1.	21-0638	HEAD, MITER MANDREL	1
2.	24-1574	PLATE, X-Y	1
3.	24-1575	PLATE, GIMBAL	1
4.	27-0606	ADAPTER, MANDREL	1
5.	29-0088	BRG, SPHR, 1" X 1 3/4" X 1"	4
6.	30-2723	INSERT, THRD, 1-8 X 1 3/8" X 1.37"	4
7.	30-2724	INSERT, THREADED	8
8.	32-0492	PIN, DOWEL, 3/4" DIA X 2"	4
9.	33-0068	SCREW, CAP, 3/8-16 X 5/8"	32
10.	33-1251	JACKSCREW ASSEMBLY	8
11.	33-0909	SCREW, GIMBAL ADJUST	4
12.	33-2661	SCREW, CAP, MODIFIED	4
13.	33-2844	SCREW, DRAW	1
14.	34-0336	WASHER, FLAT 1.25 ID	2
15.	35-0538	NUT, JAM, HEX, 1 1/4-12UNF	1
16.	44-1043	SPACER ASSEMBLY, 1.875"	8
17.	44-1044	SPACER ASSEMBLY, 4.250"	8
18.	44-1045	SPACER ASSEMBLY, 6.625"	8
19.	44-1046	SPACER ASSEMBLY, 9.000"	8
NOT SHOWN			
	36-0008	WRENCH, L, 3/16" HEX	1
	36-0011	WRENCH, L, 5/16" HEX	1
	36-0423	WRENCH, L, 3/4" HEX	1
	36-0060	WRENCH, COMBINATION, 1 1/8"	1
	36-0424	WRENCH, WELDMENT, 1 7/8"	1
	36-0245	SOCKET, 1 7/8 SZ, 3/4" DRIVE	1
	36-0356	DRIVE EXTENSION, 3/4 DRIVE X 5"	1
	36-0218	WRENCH, TEE HANDLE, 3/4" DRIVE	1

DIAL INDICATOR SLEEVE ASSEMBLY (P/N 46-0475)

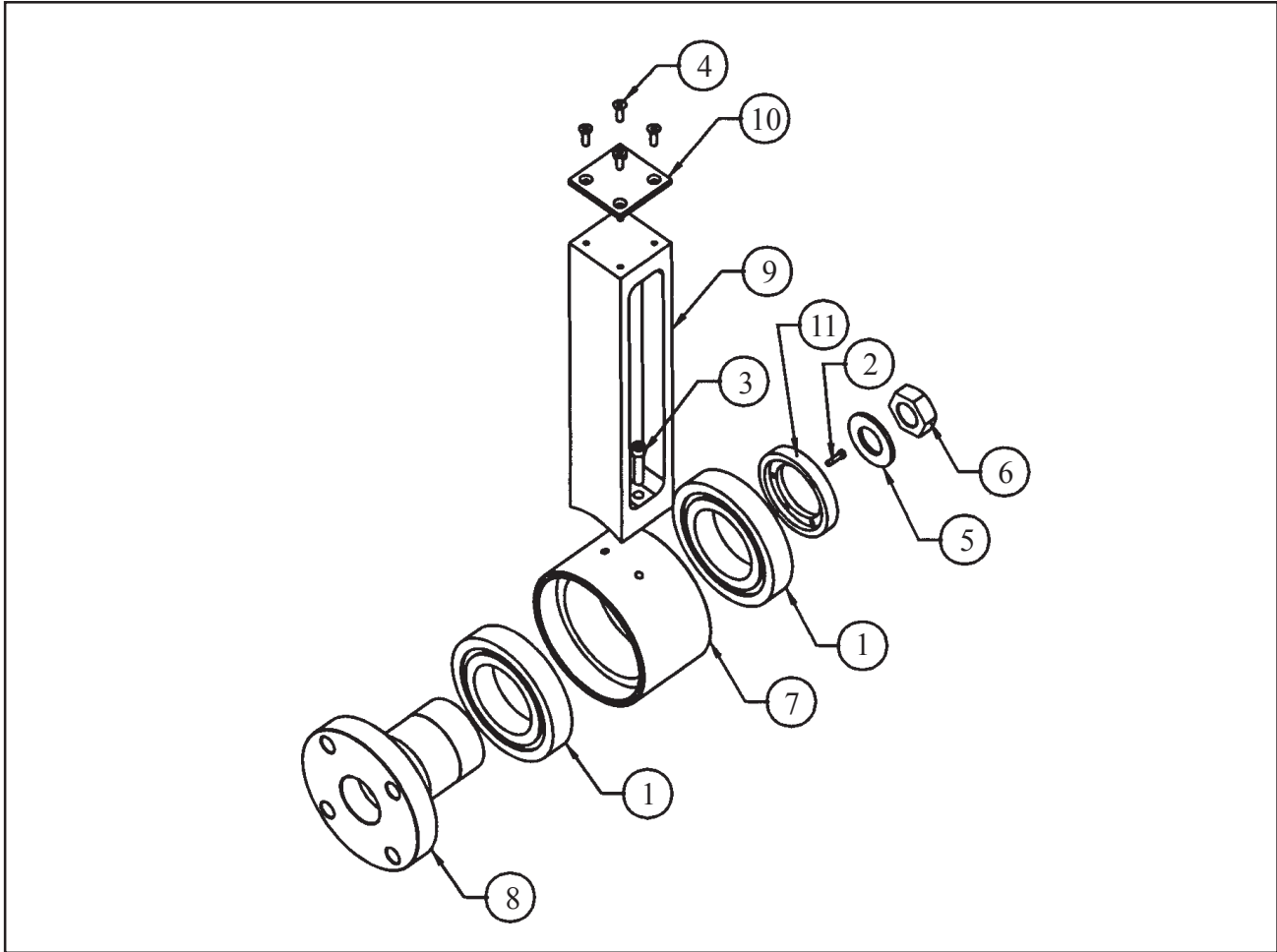

Parts List, Sleeve Assembly, Dial Indicator (P/N 46-0475)

Item No.	Part No.	Description	Qty
1.	29-0364	BEARING, BALL	2
2.	33-0030	SCREW, CAP, #10-24 UNC X 3/4"	6
3.	33-0074	SCREW, CAP, 3/8-16 UNC X 3/4"	2
4.	33-0361	SCREW, FLAT, 1/4-20 UNC X 3/4"	4
5.	34-0336	WASHER, FLAT	1
6.	35-0538	NUT, HEX	1
7.	46-0477	SLEEVE, OUTER	1
8.	46-0496	SLEEVE SUPPORT	1
9.	48-1156	BLOCK, OFFSET	1
10.	48-1157	BLOCK, DIAL INDICATOR	1
11.	54-0413	CAP, BEARING	1

DIAL INDICATOR ASSEMBLY (P/N 50-0015)

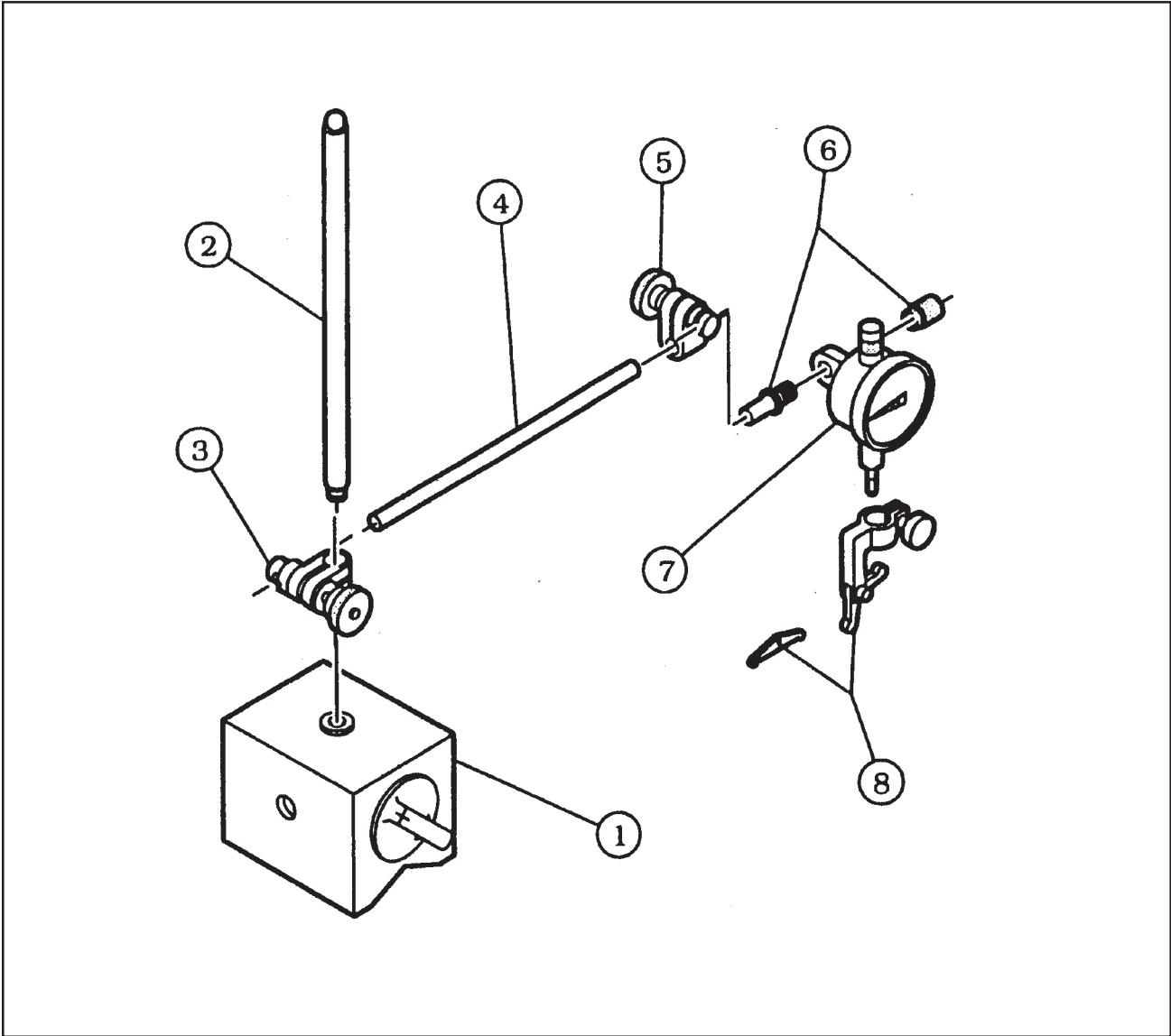

**TRI TOOL INC.**

---

## Parts List, Dial Indicator Assembly (P/N 50-0015)

<b>Item No.</b>	<b>Part No.</b>	<b>Description</b>	<b>Qty</b>
1.	30-0334	BASE, MAGNETIC	1
2.	30-0335	POST, UPRIGHT BASE	1
3.	30-0336	SLEEVE	1
4.	30-0337	ROD	1
5.	30-0338	SLEEVE	1
6.	30-0339	ATTACHMENT, INDICATOR	1
7.	30-0340	INDICATOR, DIAL	1
8.	30-0341	ATTACHMENT UNIVERSAL	1