

TABLE OF CONTENTS

| | |
|------------------------------|--------------------|
| CUSTOMER MESSAGE | Inside Front Cover |
| SAFETY PRECAUTIONS | 3 |
| GENERAL DESCRIPTION | 6 |
| SPECIFICATIONS | 7 |
| MAINTENANCE | 8 |
| OPERATION | 10 |
| ILLUSTRATED PARTS BREAKDOWN | 14 |
| TOOL BIT RESHARPENING POLICY | Inside Back Cover |
| WARRANTY INFORMATION | Inside Back Cover |

Copyright 2005

Proprietary property of TRI TOOL Inc.

No reproduction, use, or duplication of the information shown hereon is permitted without the express written consent of TRI TOOL Inc.

SAFETY PRECAUTIONS

IN GENERAL

When using rotating head cutting equipment, basic safety precautions should always be followed to reduce the risk of personal injury.

Operate this tool only in accordance with specific operating instructions.

WARNING:

Do not override the deadman switch on the power unit. Locking down, obstructing, or in any way defeating the deadman switch on the power drive unit may result in serious injury.

DRESS CONSIDERATIONS

Use standard safety equipment. Hard hats, safety shoes, safety harnesses, protective clothes, and other safety devices should always be used when appropriate.

Use safety glasses. Do not operate cutting tools without eye protection.

Dress properly. Do not wear loose clothing or jewelry. They can be caught in rotating and moving parts. Avoid slippery floors or wear nonskid footwear. If you have long hair, wear protective hair covering to contain it.

WORK AREA

Keep the work area clean. Cluttered work areas and benches invite injuries.

Consider the work area environment. Keep the area well lit. Keep electrical cords, cables, rags, rigging straps, and etc. clear of rotating equipment. Do not use power-cutting tools in the presence of flammable liquids and gasses.

Keep visitors away. Do not let visitors or untrained personnel at or near operating tools. Enforce eye protection requirements for all observers.

Do not over reach. Keep proper footing at all times.

Stay alert. Watch what you are doing. Use common sense. Do not operate tools when you are tired.

TOOL CARE

Maintain tools with care. Keep tools in good operating condition. Sharp tool bits perform better and safer than dull tool bits. Well maintained tools function properly when needed.

Check for damaged parts. If a tool has malfunctioned, been dropped or hit, it must be checked for damage. Run no-load tests and feed function checks. Do a complete visual inspection.

Electric motors. Use only with proper AC voltage power sources and observe all normal electric shock hazard procedures.

Do not abuse power and control cords. Pulling or running over cords and cables can result in electrical shock hazards and malfunctions. Keep control and power cords out of all cutting fluids and water.

Hydraulic drives. Observe proper procedures for electrically driven power sources. Avoid damage to hydraulic lines. Keep quick-disconnects clean. Grit contamination causes malfunctions.

Air tools. Check the exhaust muffler. Broken or damaged mufflers can restrict air flow or cause excessive noise. Use air motors only with a filtered, lubricated and regulated air supply. Dirty air, low-pressure air or over pressure air will cause malfunctions, including delayed starting.

AREA EQUIPMENT

Secure work. Whenever possible use clamps, vises, chains and straps to secure pipe.

Make sure the tool is secured; it is safer to have both hands free to operate the tool.

TOOL USE

Use the right tool and tool bit for the job. Do not use a tool, which is incorrect for the job you are doing.

Keep the tool bits fully engaged in the tool bit holders. Loose bits are a safety hazard.

Disconnect power supply during setup and maintenance. Use all 'Stop' or Shut off' features available when changing or adjusting tool bits, maintaining the tool, or when the tool is not in use.

Remove adjusting keys and wrenches before applying power to the equipment. Develop a habit of checking the tool before turning it on to make sure that all keys and wrenches have been removed.

Do not force tools. Tools and tool bits function better and safer when used at the feed and speed rate for which they were designed.

Do not reach into rotating equipment. Do not reach into the rotating head stock to clear chips, to make adjustments, or to check surface finish. A machine designed to cut steel will not stop for a hand or an arm.

Handle chips with care. Chips have very sharp edges and are hot. Do not try to pull chips apart with our hands; they are very tough.

Avoid unintentional starts. Do not carry or handle tools with your hand on the operating switches or levers. Do not lay the tool down in a manner that will start the drive. Do not allow the tool to flip around or move when adjusting or changing tool bits.

Store idle tools properly. Disconnect tools from the power source and store in a safe place. Remove tool bits for safe handling of the tool.

GENERAL DESCRIPTION

IN GENERAL

The Model 212B-IDTM, ID Tracking Module Kit (P/N 05-0182) is an accessory option which is used to expand the versatility of the Model 212B BEVELMASTER™.

The ID Tracking Module is designed to track out of round pipe/tube to control the land thickness on thin wall pipe/tube.

The 212B-IDTM bolts directly to the 212B BEVELMASTER™ in lieu of the standard Tool Modules.

The Tool Holder has two Slots to allow facing and beveling simultaneously.

Radial Tool Holder Spring travel of .88" (22.4 mm) accommodates pipe that is out of round.

The ID Tracking Module has interchangeable Tracking Wheel Assemblies to allow for a larger wall thickness range.

SPECIFICATIONS

Envelope, Model 212B-IDTM, ID Tracking Module

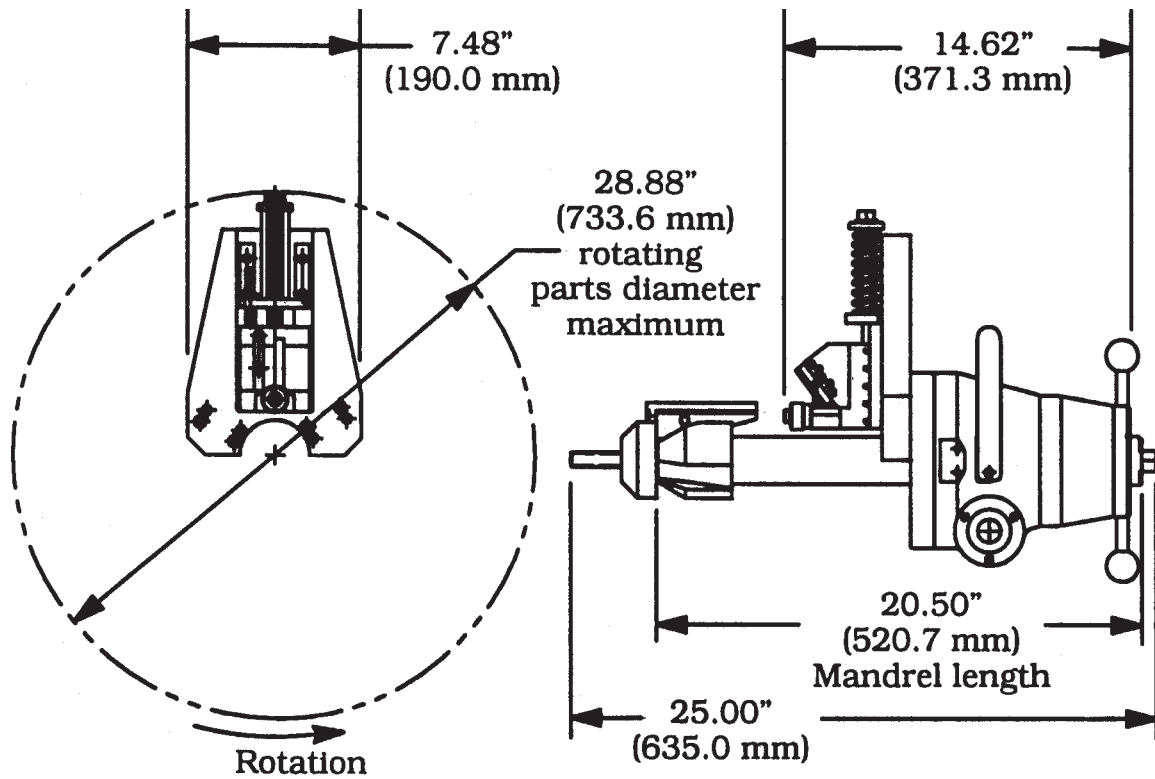

PIPE CUTTING CAPACITIES

Basic pipe sizes:

- 5" schedules 5 through 120
- 6" and 8" all schedules
- 10" schedules 5 through 140
- 12" schedules 5 through 120

Minimum ID mounting diameter: 4.498" (114.2 mm)

WALL THICKNESS CAPACITY

Short Tracking Wheel: no minimum wall thickness limitations to .750" (19.1 mm) maximum.

Long Tracking Wheel: .750" to 1.00" (19.1 mm to 25.4 mm) maximum wall thickness.

MAINTENANCE

All components should be cleaned and coated with a light film of oil prior to use.

Use a clean, non-detergent oil, preferably SAE 10 (90 SSU) or lighter.

If the Model 212B-IDTM is operated in such a manner that the Tool Block collect debris while cutting, the Tool Block and the Feed Screw should be cleaned after each cutting operation.

Clean Up

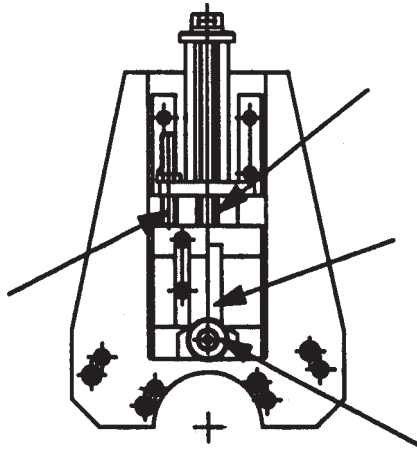

WARNING: Tool life may be severely shortened, unless chips and/or other debris that have been deposited on the Cutting Head during the machining operation are removed.

RECOMMENDED MAINTENACE SCHEDULE

Daily maintenance when the unit is in operation:

Wipe the unit down and spray with rust preventative under severe humidity conditions.

Visually inspect for loose screws, missing screws, damage, etc.

After every 20 hours of actual operation:

Clean and lubricate the Slide Rails.

Disassemble the unit and wipe the Slide Rails.

Excess lubricant will collect grit and/or chips and tend to cause jamming and/or damage to the Slide Rails.

STORAGE

If the ID Tracking Module is to be stored or if it will remain out of service for a significant period of time (30 days or more), it should be thoroughly cleaned, lubricated and sprayed with a rust preventative prior to storage.

OPERATION

Read the Operating Instructions carefully before attempting to operate the Model 212B-IDTM.

Refer to the Operator's Manual for Operating Instructions for the Model 212B BEVELMASTER™.

Remove the (3) three Tool Holders from the Model 212B.

Mount the Model 212B-IDTM to the 212B Headstock using the (8) eight Cap Screws that have been provided.

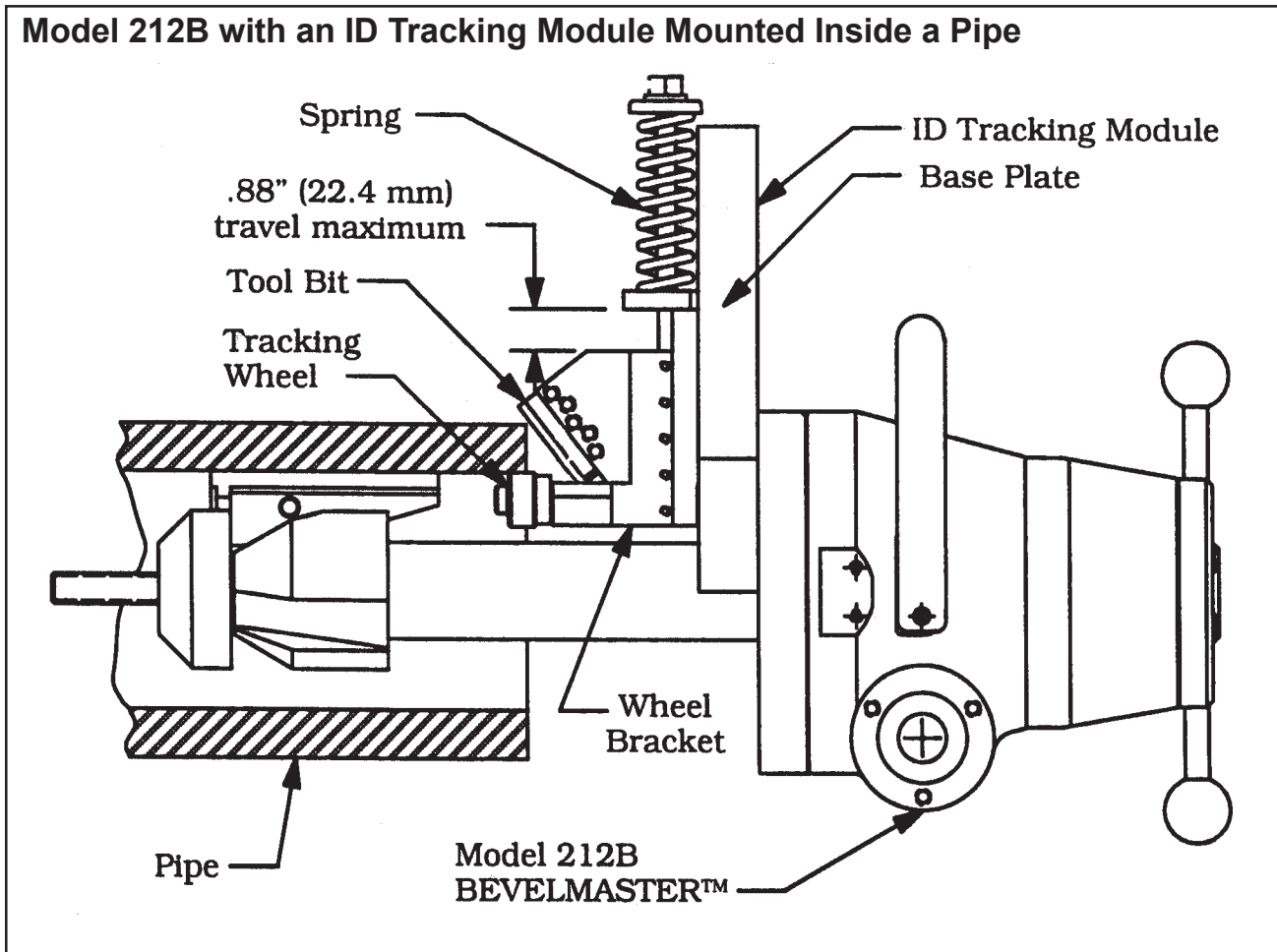

Install the Mandrel Assy into the pipe.

NOTE:

Use the Extended Mandrel provided with the Model 212B-IDTM Kit with the Standard Jaw Blocks, Ramps and Adapters.

Position the ID Tracking Module Assy so that the Tracking Wheel is in contact with the ID of the pipe.

Tightly lock the Retaining Plates in place with the Hold Down Screws from the back of the Base Plate.

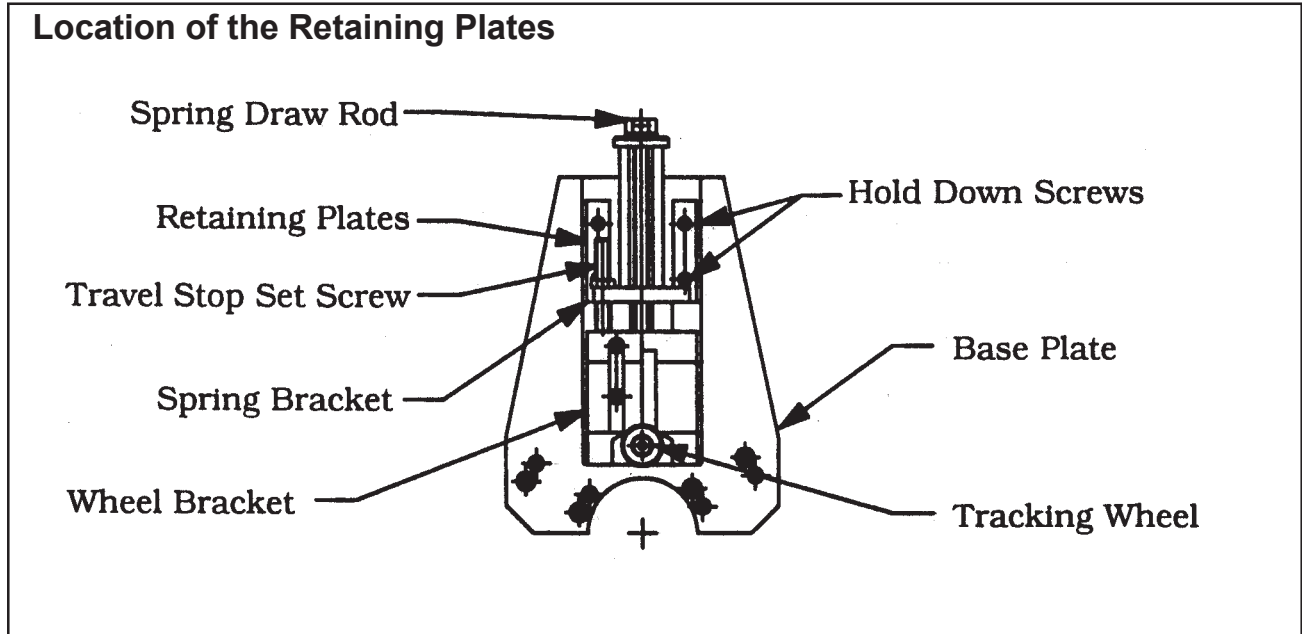

Tighten the Spring Draw Rod, but leave enough travel to accommodate out of round pipe.

NOTE:

Make sure the Travel Stop Set Screw is retracted back flush with the bottom of the Spring Bracket.

Install the Tool Bits in the ID Tracking Module.

Install the Beveling Tool Bit with the cutting edge on the centerline of the pipe or tube.

The Land thickness will be determined by the position of the Beveling Tool bit in the slot.

Slide the Beveling Tool Bit up and down in the slot keeping the bottom of the Tool Bit flat against the bottom of the slot.

Once the desired position has been achieved, then tighten all of the Set Screws which make contact with the Tool Bit.

Install the Facing (Land) Tool Bit with the cutting edge to the outside of the Tool Holder.

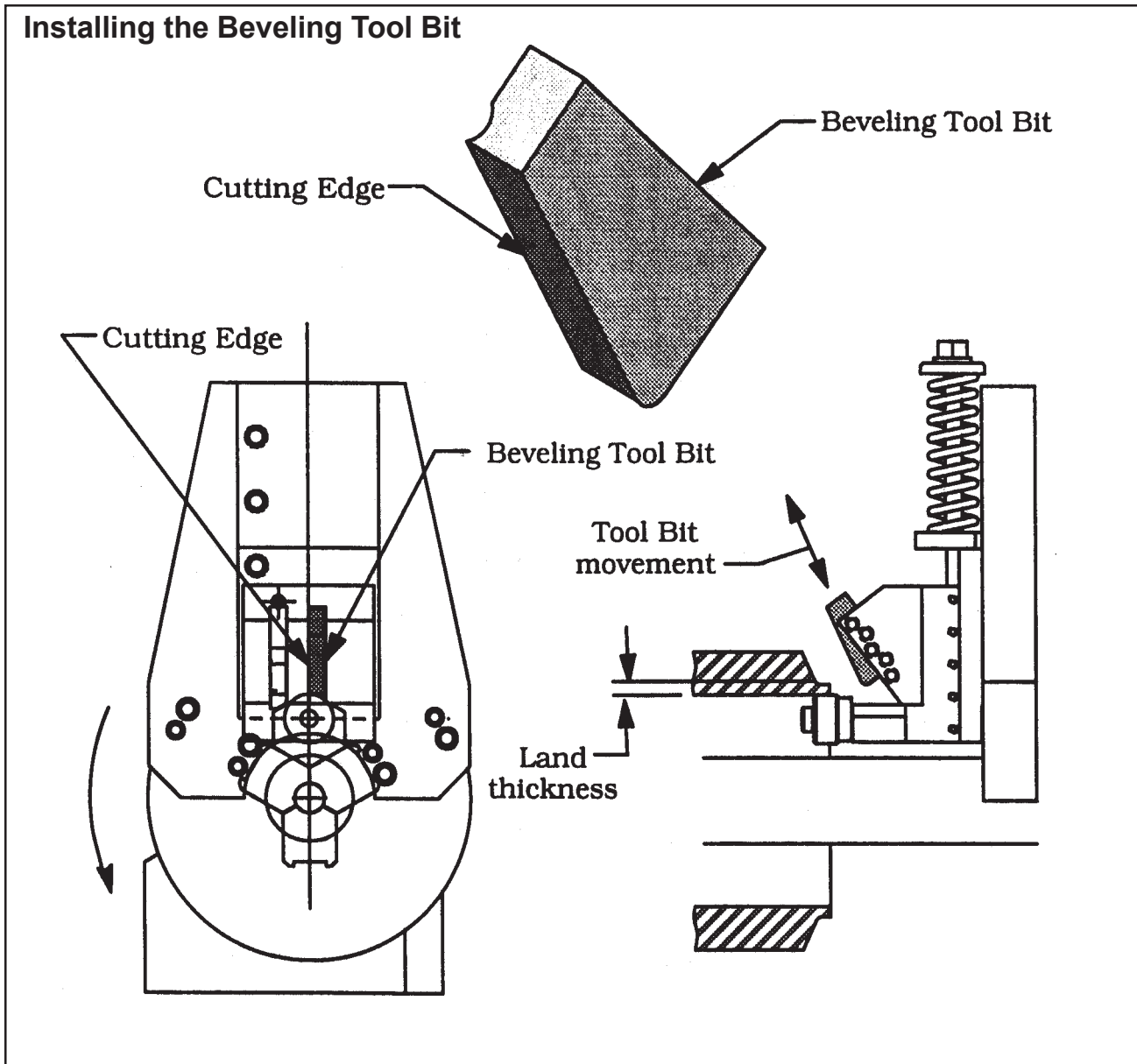

The Land width will be determined by the position of the Beveling Tool Bit in the slot.

Slide the Facing Tool Bit up and down in the slot keeping the bottom of the Tool Bit flat against the bottom of the slot.

Once the desired position has been achieved, then tighten all of the Set Screws which make contact with the Facing Tool Bit.

Attach the proper power supply line to the Model 212B.

NOTE: Check that the Air Supply (FRL) is installed and set properly.

Turn the Motor on and start cutting.

Installation of the Facing (Land) Tool Bit

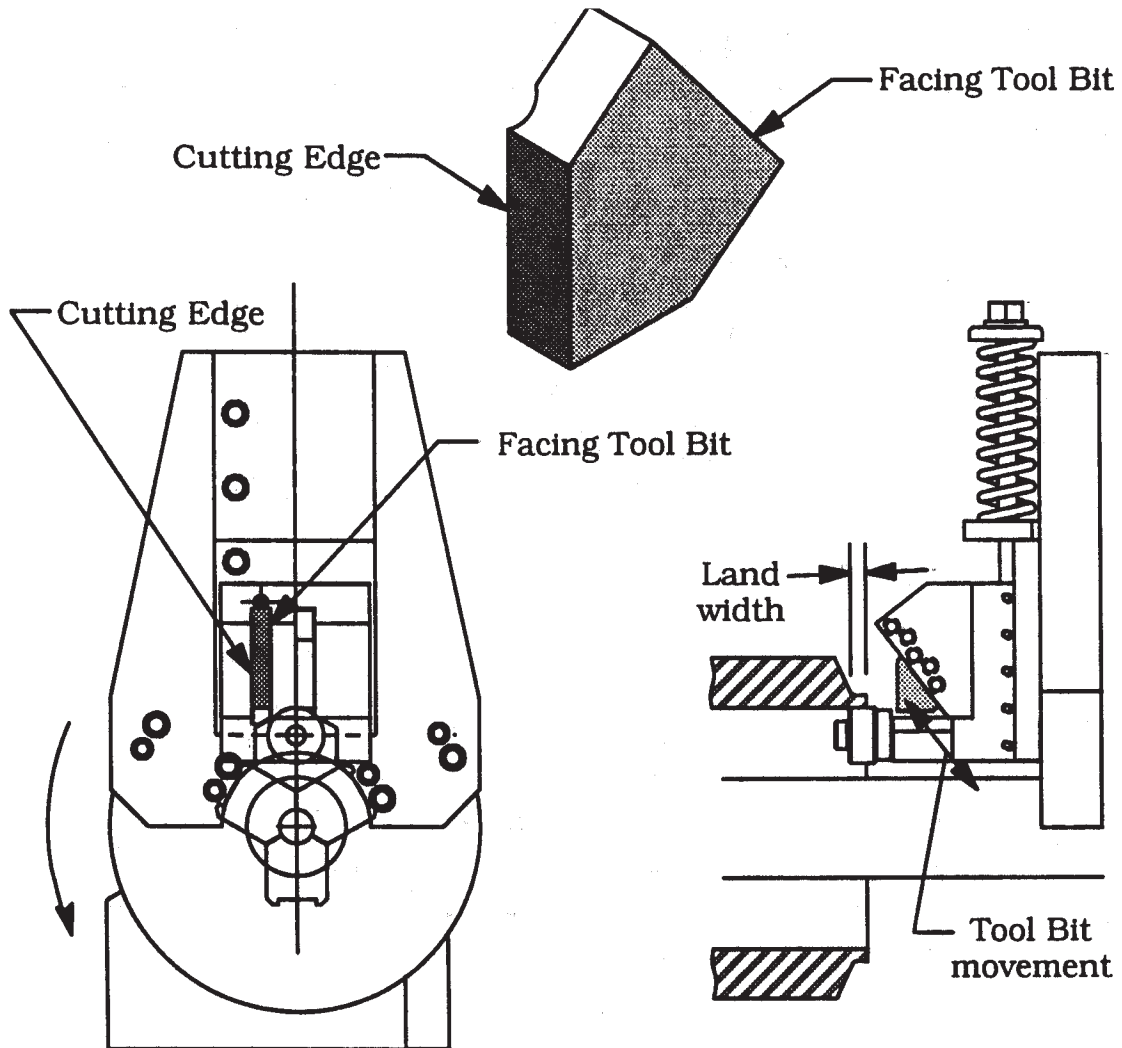

After the cut is finished, turn the Motor off to stop the Headstock rotation.

Tighten down the Travel Stop Set Screw and lock it against the wheel Bracket to prevent the spring from releasing when removing the machine from the pipe.

ID Tracking Module for the Model 212B

Parts List, ID Tracking Module (P/N 82-0086)

| Item No. | Part No. | Description | Qty |
|------------|----------|------------------------------------|-----|
| 1. | 11-0089 | ROD ASSY, DRAW | 1 |
| 2. | 24-1146 | PLATE, SLIDE | 1 |
| 3. | 24-1155 | PLATE, BASE | 1 |
| 4. | 24-1156 | PLATE, RETAINING | 2 |
| 5. | 33-0038 | SCREW, CAP, 1/4-20 X 1/2 | 5 |
| 6. | 33-0039 | SCREW, CAP, 1/4-20 X 5/8 | 2 |
| 7. | 33-0043 | SCREW, CAP, 1/4-20 X 1 1/4 | 1 |
| 8. | 33-0044 | SCREW, CAP, 1/4-20 X 1 1/2 | 4 |
| 9. | 33-0055 | SCREW, CAP, 5/16-18 X 7/8 | 8 |
| 10. | 33-0057 | SCREW, CAP, 5/16-18 X 1 1/4 | 4 |
| 11. | 33-0499 | SCREW, SET, 1/4-20 X 1/4, CUP PT | 1 |
| 12. | 33-0517 | SCREW, SET, 5/16-18 X 5/8, CUP PT | 5 |
| 13. | 33-0520 | SCREW, SET, 5/16-18 X 1, CUP PT | 5 |
| 14. | 33-0538 | SCREW, SET, 3/8-16 X 2 1/2, CUP PT | 1 |
| 15. | 33-0914 | SCREW, SET, #10-24 X 1/2, HDOG | 5 |
| 16. | 33-1009 | SCREW, SHOULDER, 3/8 DIA X 1 1/2 | 1 |
| | 33-1757 | SCREW, SHOULDER, 3/8 X 1 1/4 | 1 |
| 17. | 34-0267 | WASHER, SPRING | 1 |
| 18. | 35-0192 | NUT, JAM | 1 |
| 19. | 35-0363 | NUT, FEED | 1 |
| 20. | 40-0182 | SPRING, COMPRESSION | 1 |
| 21. | 47-0749 | BRACKET, SPRING | 1 |
| 22. | 47-0757 | BRACKET, WHEEL | 1 |
| 23. | 49-0242 | HOLDER, TOOL | 1 |
| 24. | 61-0057 | WHEEL ASSY, TRACKING | 1 |
| | 61-0058 | WHEEL ASSY, TRACKING | 1 |
| 25. | 66-0120 | GIB | 1 |
| NOT SHOWN: | | | |
| | 36-0003 | WRENCH, L, 3/32" HEX | 1 |
| | 36-0007 | WRENCH, L, 5/32" HEX | 1 |
| | 36-0008 | WRENCH, L, 3/16" HEX | 1 |
| | 36-0010 | WRENCH, L, 1/4" HEX | 1 |
| | 36-0043 | WRENCH, COMBINATION, 11/16" | 1 |
| | 36-0076 | WRENCH, COMBINATION, 9/16" | 1 |
| | 86-0195 | CASE, CARRYING | 1 |

MANDREL ASSEMBLY (P/N 06-0392)

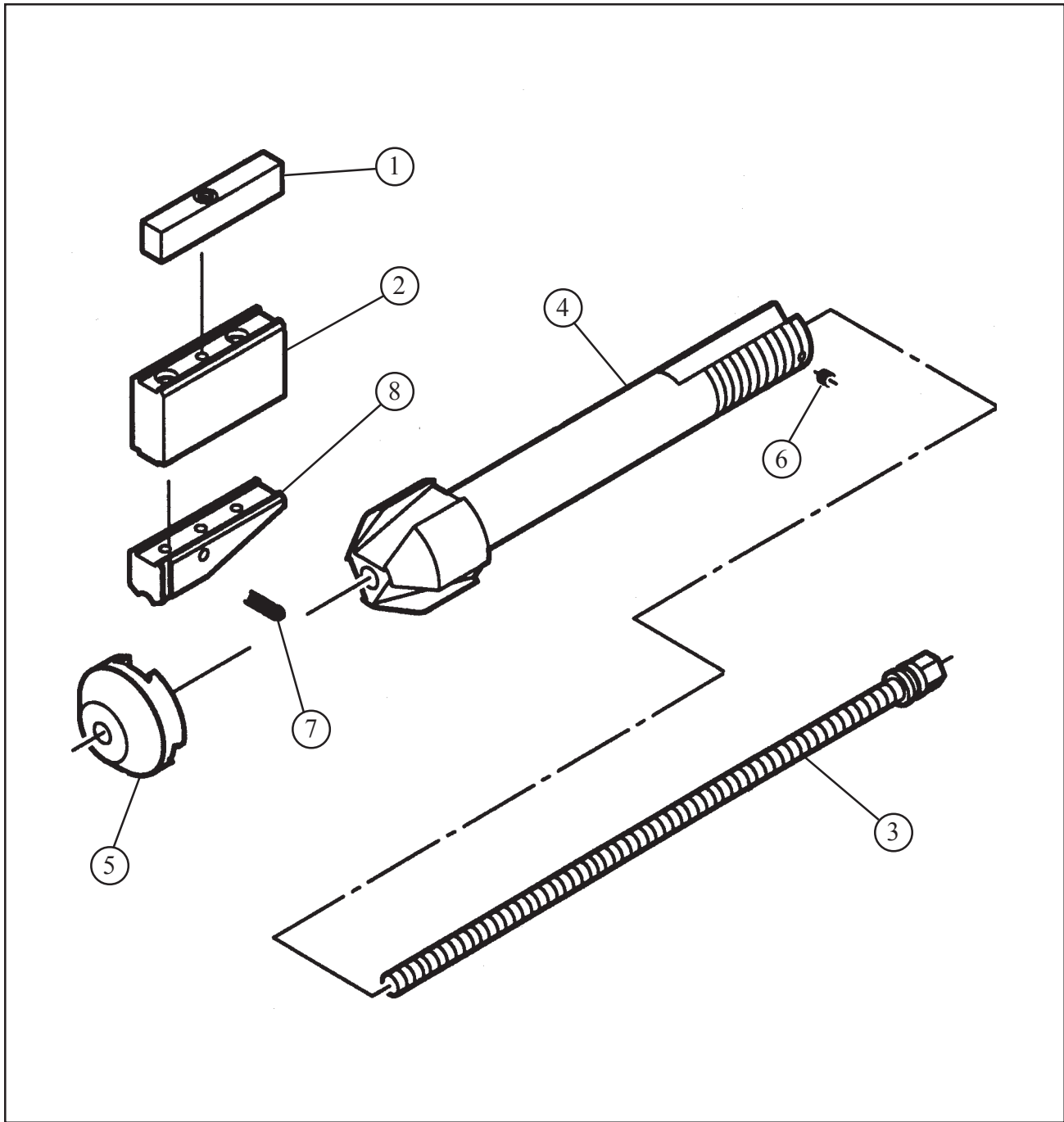

ID Tracking Module for the Model 212B

Parts List, Mandrel Assembly (P/N 06-0392)

| Item No. | Part No. | Description | Qty |
|-----------------|-----------------|--------------------------------|------------|
| 1. | 08-0185 | BLOCK ASSY, JAW, .609" | ref |
| 1. | 08-0186 | BLOCK ASSY, JAW, 1.096" | ref |
| 1. | 08-0187 | BLOCK ASSY, JAW, 1.583" | ref |
| 1. | 08-0188 | BLOCK ASSY, JAW, 2.070" | ref |
| 2. | 08-0189 | BLOCK ASSY, ADAPTOR | ref |
| 3. | 11-0086 | ROD ASSY, DRAW | 1 |
| 4. | 13-0388 | MANDREL | 1 |
| 5. | 24-0799 | PLATE, BUTT | ref |
| 6. | 33-0928 | SCREW, SET, 1/4-20 X 3/8, HDOG | 2 |
| 7. | 40-0172 | SPRING, EXTENSION, MOD | ref |
| 8. | 48-0520 | BLOCK, RAMP | ref |