

TABLE OF CONTENTS

CUSTOMER MESSAGE	Inside Front Cover
SAFETY PRECAUTIONS	3
SPECIFICATIONS	6
CENTERING PINS	7
OPERATION	10
MAINTAINANCE	11
TROUBLE SHOOTING	12
ILLUSTRATED PARTS BREAKDOWN	14
TOOL BIT RESHARPENING POLICY	Inside Back Cover
WARRANTY INFORMATION	Inside Back Cover

Copyright 2005

Proprietary property of TRI TOOL Inc.

No reproduction, use, or duplication of the information
shown hereon is permitted without the express written
consent of TRI TOOL Inc.

SAFETY PRECAUTIONS

IN GENERAL

When using rotating head cutting equipment, basic safety precautions should always be followed to reduce the risk of personal injury.

Operate this tool only in accordance with specific operating instructions.

WARNING:

Do not override the deadman switch on the power unit. Locking down, obstructing, or in any way defeating the deadman switch on the power drive unit may result in serious injury.

DRESS CONSIDERATIONS

Use standard safety equipment. Hard hats, safety shoes, safety harnesses, protective clothes, and other safety devices should always be used when appropriate.

Use safety glasses. Do not operate cutting tools without eye protection.

Dress properly. Do not wear loose clothing or jewelry. They can be caught in rotating and moving parts. Avoid slippery floors or wear nonskid footwear. If you have long hair, wear protective hair covering to contain it.

WORK AREA

Keep the work area clean. Cluttered work areas and benches invite injuries.

Consider the work area environment. Keep the area well lit. Keep electrical cords, cables, rags, rigging straps, and etc. clear of rotating equipment. Do not use power-cutting tools in the presence of flammable liquids and gasses.

Keep visitors away. Do not let visitors or untrained personnel at or near operating tools. Enforce eye protection requirements for all observers.

Do not over reach. Keep proper footing at all times.

Stay alert. Watch what you are doing. Use common sense. Do not operate tools when you are tired.

TOOL CARE

Maintain tools with care. Keep tools in good operating condition. Sharp tool bits perform better and safer than dull tool bits. Well maintained tools function properly when needed.

Check for damaged parts. If a tool has malfunctioned, been dropped or hit, it must be checked for damage. Run no-load tests and feed function checks. Do a complete visual inspection.

Electric motors. Use only with proper AC voltage power sources and observe all normal electric shock hazard procedures.

Do not abuse power and control cords. Pulling or running over cords and cables can result in electrical shock hazards and malfunctions. Keep control and power cords out of all cutting fluids and water.

Hydraulic drives. Observe proper procedures for electrically driven power sources. Avoid damage to hydraulic lines. Keep quick-disconnects clean. Grit contamination causes malfunctions.

Air tools. Check the exhaust muffler. Broken or damaged mufflers can restrict air flow or cause excessive noise. Use air motors only with a filtered, lubricated and regulated air supply. Dirty air, low-pressure air or over pressure air will cause malfunctions, including delayed starting.

AREA EQUIPMENT

Secure work. Whenever possible use clamps, vises, chains and straps to secure pipe.

Make sure the tool is secured; it is safer to have both hands free to operate the tool.

TOOL USE

Use the right tool and tool bit for the job. Do not use a tool, which is incorrect for the job you are doing.

Keep the tool bits fully engaged in the tool bit holders. Loose bits are a safety hazard.

Disconnect power supply during setup and maintenance. Use all 'Stop' or Shut off' features available when changing or adjusting tool bits, maintaining the tool, or when the tool is not in use.

Remove adjusting keys and wrenches before applying power to the equipment. Develop a habit of checking the tool before turning it on to make sure that all keys and wrenches have been removed.

Do not force tools. Tools and tool bits function better and safer when used at the feed and speed rate for which they were designed.

Do not reach into rotating equipment. Do not reach into the rotating head stock to clear chips, to make adjustments, or to check surface finish. A machine designed to cut steel will not stop for a hand or an arm.

Handle chips with care. Chips have very sharp edges and are hot. Do not try to pull chips apart with are hands; they are very tough.

Avoid unintentional starts. Do not carry or handle tools with your hand on the operating switches or levers. Do not lay the tool down in a manner that will start the drive. Do not allow the tool to flip around or move when adjusting or changing tool bits.

Store idle tools properly. Disconnect tools from the power source and store in a safe place. Remove tool bits for safe handling of the tool.

SPECIFICATIONS

IN GENERAL:

Elbow Mandrels have been designed to expand the versatility of the Model 212B Pipe Beveler.





These mandrels, when used in conjunction with the Model 212B, allow machining of pipe elbows, weld neck flanges, and pipe, that have a very short perch length.

The Elbow Mandrel for the Model 212B will mount in pipe or tubing with a range of 3.31" to 13.12" (84.1 mm to 333.2 mm) inside diameter.

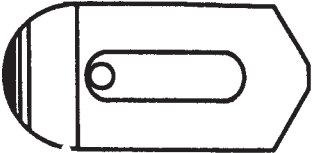
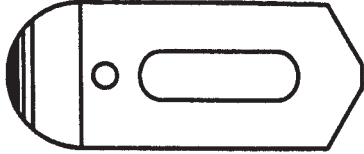

The Elbow Mandrel is designed to mount inside an elbow or other similar locations.

CENTERING PINS

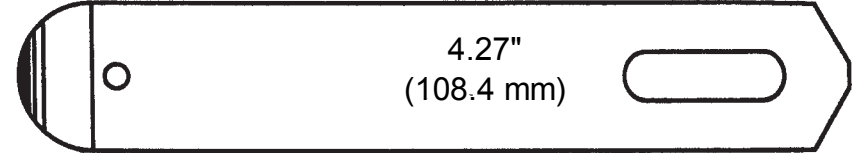
Pin Length Measuring Guide

Contact Pin P/N	Pin Chart
32-0318	 <div style="float: right;">1.58" (40.0 mm)</div>
32-0319	 <div style="float: right;">2.03" (51.5 mm)</div>
32-0320	 <div style="float: right;">2.48" (63.0 mm)</div>
32-0321	 <div style="float: right;">2.91" (73.9 mm)</div>
32-0322	 <div style="float: right;">3.36" (85.4mm)</div>
32-0323	 <div style="float: right;">3.82" (96.9 mm)</div>
32-0324	 <div style="float: right;">4.27" (108.4 mm)</div>

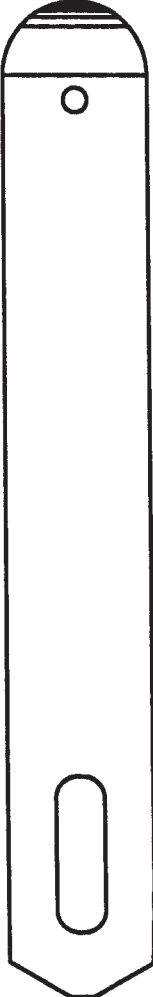
Pin Length Measuring Guide Continued

Contact Pin P/N	32-0325	32-0326	32-0327	32-0328
Pin Chart				
	<p>4.70" (119.3 mm)</p>	<p>5.15" (130.8 mm)</p>	<p>5.60" (142.3 mm)</p>	<p>6.06" (153.8 mm)</p>

ELBOW MANDREL KIT - ID MOUNTING RANGES				
Head Assy P/N	Contact Pin P/N	ID Mounting Range		Pin Length
		"A" dia minimum	"B" dia Maximum	
21-0245	32-0318	3.31" (84.1 mm)	4.16" (105.7 mm)	1.575" (40.0 mm)
	32-0319	4.15" (105.4 mm)	5.06" (128.5 mm)	2.028" (51.5 mm)
	32-0320	5.06" (128.5 mm)	5.97" (151.6 mm)	2.481" (63.0 mm)
21-0246	32-0321	5.91" (150.1 mm)	6.82" (173.2 mm)	2.909" (73.9 mm)
	32-0322	6.82" (173.2 mm)	7.73" (196.3 mm)	3.362" (85.4 mm)
	32-0323	7.73" (196.3 mm)	8.64" (219.5 mm)	3.815" (96.9 mm)
	32-0324	8.64" (219.5 mm)	9.54" (242.3 mm)	4.268" (108.4 mm)
21-0247	32-0325	9.49" (241.0 mm)	10.39" (263.9 mm)	4.696" (119.3 mm)
	32-0326	10.40" (264.2 mm)	11.39" (289.3 mm)	5.149" (130.8 mm)
	32-0327	11.30" (287.0 mm)	12.21" (310.1 mm)	5.602" (142.3 mm)
	32-0328	12.21" (310.1 mm)	13.12" (333.2 mm)	6.055" (153.8 mm)

OPERATION

IN GENERAL

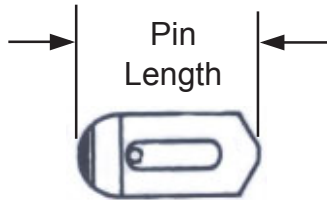

Correct pin length is important for rigidity. Use only the correct Contact Pins specified for each head size.

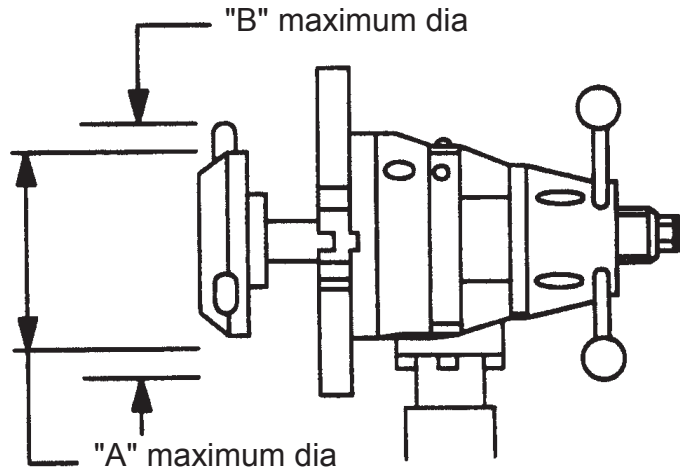

MANDREL SET-UP IN AN ELBOW

The Mandrel should be set-up in the elbow so that one pin contacts the inside diameter of the elbow at the top.

This will help center the Mandrel.

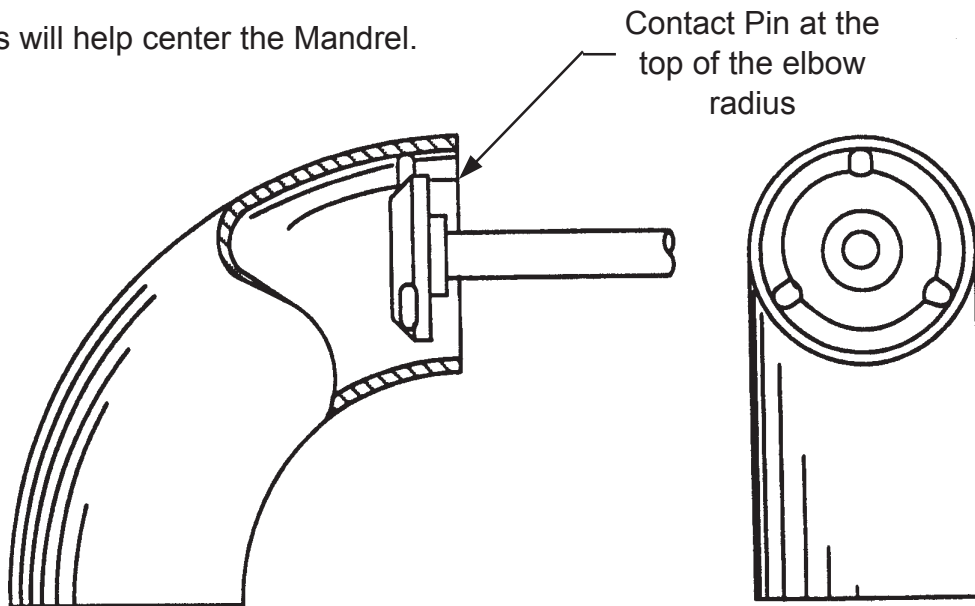

OPTIONAL ACCESSORY

05-0357, Adjustable Centering Pin Kit.

The Kit is used, with the Standard Centering Pins, for centerline adjustment of the Mandrel into the elbow.

MAINTENANCE

IN GENERAL

All components should be cleaned and coated with a light film of oil prior to storage.

If the mandrel is operated in such a way that the mandrel collects chips or debris near the head, the head should be cleaned after each cutting operation.

DAILY MAINTENANCE

Wipe the unit down and spray with a rust preventative under severe humidity conditions.

Visually inspect for loose screws, missing bolts, or damage due to impact.

Contact TRI TOOL Inc. if major repair is required.

Tighten or replace screws or other parts as required.

TROUBLE SHOOTING

Problem: The Tool Bit Chatters

Probable causes:

- The tool bit is loose or overextended.
- The tool bit is damaged.
- The tool holder is too loose in the slides.
- The cutting speed is too fast.
- The clamping pads are loose on the pipe or tube.
- Cutting fluid is required.
- The main bearing pre-load is loose.

Problem: There is excessive Tool Bit wear

Probable causes:

- The pipe or tube material is too hard or abrasive.
- The cutting speed is too fast.
- Cutting fluid is required.
- A dull Tool Bit is causing surface hardening conditions (Stainless pipe or tubing).
- There is scale or other foreign matter on the pipe or tube, which is dulling the tool bit at the start of the cut.
- The tool bit is incorrect for the material being cut.

Problem: The surface finish is rough

Probable causes:

- The tool bit is dull, chipped, etc.
- Metal build-up on the cutting edge of the tool bit is creating a false cutting edge.
- Cutting fluid is required.

Problem: The tool holder is not feeding

Probable causes:

- The feed pin is broken or out of position.
- The feed sprocket shear pin is broken.
- The feed screw is stripped.
- The feed nut is stripped.
- The slide rails are too tight.

Problem: There is a loss of air power

Probable causes:

- The air supply pressure is too low.
- The air filter is plugged.
- The air line size is insufficient.
- The air line is too long.

Problem: There is a loss of hydraulic power

Probable causes:

- The hydraulic supply pressure is too low.
- The hydraulic filter is plugged.
- The hydraulic line size is insufficient.
- The hydraulic line is too long.

Problem: The tool bit will not reach the work

Probable causes:

- Incorrect tool blocks are installed for the size of the pipe or tube being worked on.
- Incorrect tool bit is installed.

Problem: The hydraulic motor will not start

Probable causes:

- The hydraulic power supply is shut off.
- The hydraulic motor is damaged and will not run free.

ILLUSTRATED PARTS BREAKDOWN

ELBOW MANDREL ASSEMBLY

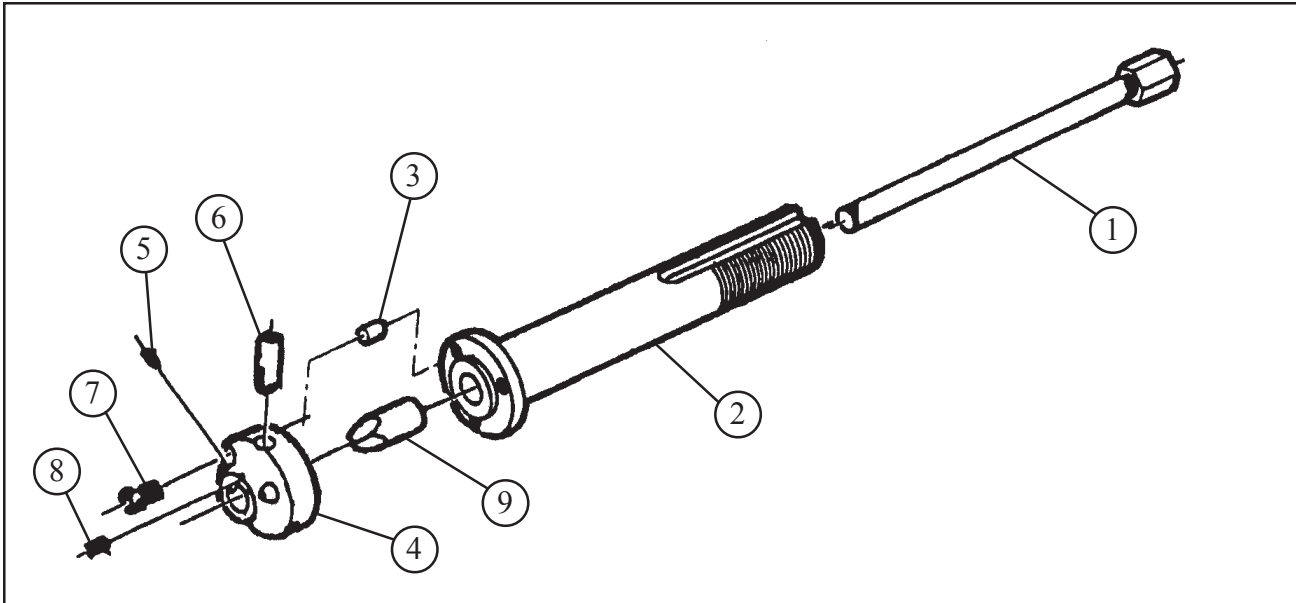

Parts List, Mandrel Assy, Elbow (P/N 06-0319)

Item No.	Part No.	Description	Qty
1.	11-0062	ROD ASSY, PUSH	1
	12-0115	MANDREL SUB-ASSY	1
2.	13-0315	MANDREL	1
3.	32-0118	PIN, DOWEL, 3/8 DIA X 3/4	1
	21-0245	HEAD ASSY, #1	1
4.	21-0242	HEAD #1	1
5.	32-0023	PIN, ROLL, 1/8 DIA X 3/8	3
6.	32-0318	PIN, CENTERING, 1.575 LG.	3
	32-0319	PIN, CENTERING, 2.028 LG.	3
	32-0320	PIN, CENTERING, 2.481 LG.	3
7.	33-0070	SCREW, CAP, 3/8-16 X 7/8	3
8.	33-0928	SCREW, SET, 1/4-20 X 3/8, HDOG	3
9.	54-0297	PLUG	1

ELBOW MANDREL ASSEMBLY

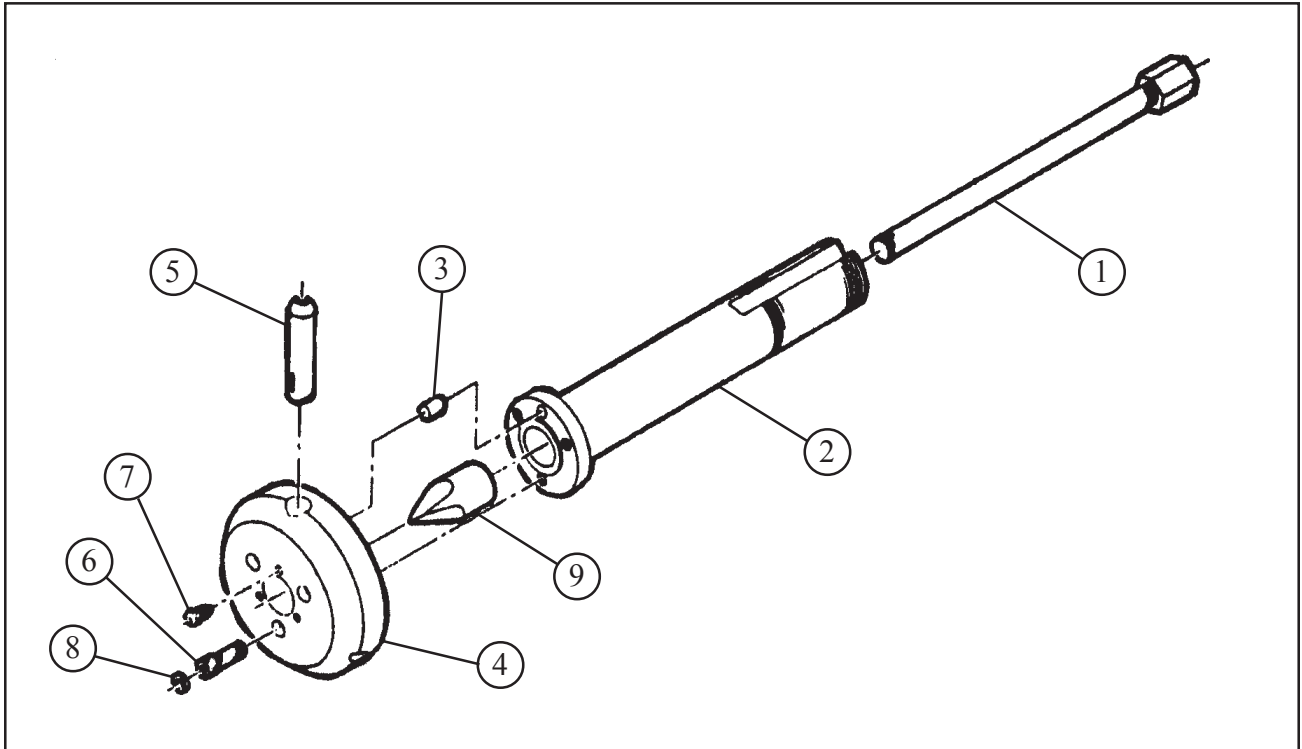

Parts List, Mandrel Assy, Elbow (P/N 06-0320)

Item No.	Part No.	Description	Qty
1.	11-0062	ROD ASSY, PUSH	1
	12-0115	MANDREL SUB-ASSY	1
2.	13-0315	MANDREL	1
3.	32-0118	PIN, DOWEL, 3/8 DIA X 3/4	1
	21-0246	HEAD ASSY, #2	1
4.	21-0243	HEAD #2	1
5.	32-0321	PIN, CENTERING, 2.909 LG.	3
	32-0322	PIN, CENTERING, 3.362 LG.	3
	32-0323	PIN, CENTERING, 3.815 LG.	3
	32-0324	PIN, CENTERING, 4.268 LG.	3
6.	33-0071	SCREW, CAP, 3/8-16 X 1	3
7.	33-0928	SCREW, SET, 1/4-20 X 3/8, HDOG	3
8.	34-0233	WASHER, NYLON	3
9.	54-0297	PLUG	1

TRI TOOL INC.

Parts List, Mandrel Assy, Elbow (P/N 06-0321)

Item No.	Part No.	Description	Qty
1.	11-0062	ROD ASSY, PUSH	1
	12-0115	MANDREL SUB-ASSY	1
2.	13-0315	MANDREL	1
3.	32-0118	PIN, DOWEL, 3/8 DIA X 3/4	1
	21-0247	HEAD ASSY, #3	1
4.	21-0244	HEAD #3	1
5.	32-0325	PIN, CENTERING, 4.696 LG.	3
	32-0326	PIN, CENTERING, 5.149 LG.	3
	32-0327	PIN, CENTERING, 5.602 LG.	3
	32-0328	PIN, CENTERING, 6.055 LG.	3
6.	33-0071	SCREW, CAP, 3/8-16 X 1	3
7.	33-0928	SCREW, SET, 1/4-20 X 3/8, HDOG	3
8.	34-0233	WASHER, NYLON	3
9.	54-0297	PLUG	1
NOT SHOWN:			
	36-0005	WRENCH, L, 1/8" HEX	1
	36-0011	WRENCH, L, 5/16" HEX	1
	36-0018	WRENCH, T, 1/8" HEX	1
	36-0024	WRENCH, L, 5/16" HEX	1
	36-0042	WRENCH, COMBINATION, 7/8"	1
	86-0146	CASE, CARRYING	1