

## TABLE OF CONTENTS

CUSTOMER MESSAGE	Inside Front Cover
SAFETY PRECAUTIONS	3
OPERATION	6
ILLUSTRATED PARTS BREAKDOWN	8
TOOL BIT RESHARPENING POLICY	Inside Back Cover
WARRANTY INFORMATION	Inside Back Cover

Copyright 2006  
Proprietary property of TRI TOOL Inc.  
No reproduction, use, or duplication of the information  
shown hereon is permitted without the express written  
consent of TRI TOOL Inc.

## SAFETY PRECAUTIONS

### IN GENERAL

When using rotating head cutting equipment, basic safety precautions should always be followed to reduce the risk of personal injury.

Operate this tool only in accordance with specific operating instructions.

#### **WARNING:**

Do not override the deadman switch on the power unit. Locking down, obstructing, or in any way defeating the deadman switch on the power drive unit may result in serious injury.

### DRESS CONSIDERATIONS

Use standard safety equipment. Hard hats, safety shoes, safety harnesses, protective clothes, and other safety devices should always be used when appropriate.

Use safety glasses. Do not operate cutting tools without eye protection.

Dress properly. Do not wear loose clothing or jewelry. They can be caught in rotating and moving parts. Avoid slippery floors or wear nonskid footwear. If you have long hair, wear protective hair covering to contain it.

### WORK AREA

Keep the work area clean. Cluttered work areas and benches invite injuries.

Consider the work area environment. Keep the area well lit. Keep electrical cords, cables, rags, rigging straps, and etc. clear of rotating equipment. Do not use power-cutting tools in the presence of flammable liquids and gasses.

Keep visitors away. Do not let visitors or untrained personnel at or near operating tools. Enforce eye protection requirements for all observers.

Do not over reach. Keep proper footing at all times.

Stay alert. Watch what you are doing. Use common sense. Do not operate tools when you are tired.

### **TOOL CARE**

Maintain tools with care. Keep tools in good operating condition. Sharp tool bits perform better and safer than dull tool bits. Well maintained tools function properly when needed.

Check for damaged parts. If a tool has malfunctioned, been dropped or hit, it must be checked for damage. Run no-load tests and feed function checks. Do a complete visual inspection.

Electric motors. Use only with proper AC voltage power sources and observe all normal electric shock hazard procedures.

Do not abuse power and control cords. Pulling or running over cords and cables can result in electrical shock hazards and malfunctions. Keep control and power cords out of all cutting fluids and water.

Hydraulic drives. Observe proper procedures for electrically driven power sources. Avoid damage to hydraulic lines. Keep quick-disconnects clean. Grit contamination causes malfunctions.

Air tools. Check the exhaust muffler. Broken or damaged mufflers can restrict air flow or cause excessive noise. Use air motors only with a filtered, lubricated and regulated air supply. Dirty air, low-pressure air or over pressure air will cause malfunctions, including delayed starting.

### **AREA EQUIPMENT**

Secure work. Whenever possible use clamps, vises, chains and straps to secure pipe.

Make sure the tool is secured; it is safer to have both hands free to operate the tool.

### **TOOL USE**

Use the right tool and tool bit for the job. Do not use a tool, which is incorrect for the job you are doing.

Keep the tool bits fully engaged in the tool bit holders. Loose bits are a safety hazard.

## Model 204B, 206B, 212B EM Squaring Plate Kits

---

Disconnect power supply during setup and maintenance. Use all 'Stop' or Shut off' features available when changing or adjusting tool bits, maintaining the tool, or when the tool is not in use.

Remove adjusting keys and wrenches before applying power to the equipment. Develop a habit of checking the tool before turning it on to make sure that all keys and wrenches have been removed.

Do not force tools. Tools and tool bits function better and safer when used at the feed and speed rate for which they were designed.

Do not reach into rotating equipment. Do not reach into the rotating head stock to clear chips, to make adjustments, or to check surface finish. A machine designed to cut steel will not stop for a hand or an arm.

Handle chips with care. Chips have very sharp edges and are hot. Do not try to pull chips apart with your hands; they are very tough.

Avoid unintentional starts. Do not carry or handle tools with your hand on the operating switches or levers. Do not lay the tool down in a manner that will start the drive. Do not allow the tool to flip around or move when adjusting or changing tool bits.

Store idle tools properly. Disconnect tools from the power source and store in a safe place. Remove tool bits for safe handling of the tool.

## OPERATION

### IN GENERAL

The Squaring Plate Assembly is designed to be used as an aide to setting up the elbow mandrel in a pipe elbow.

Secure the (3) three extension arms on the Squaring Plate Adapter.

The end of the pipe elbow will be in contact with each when the center of the pipe elbow is roughly the same as the center of the Squaring Plate Assembly.

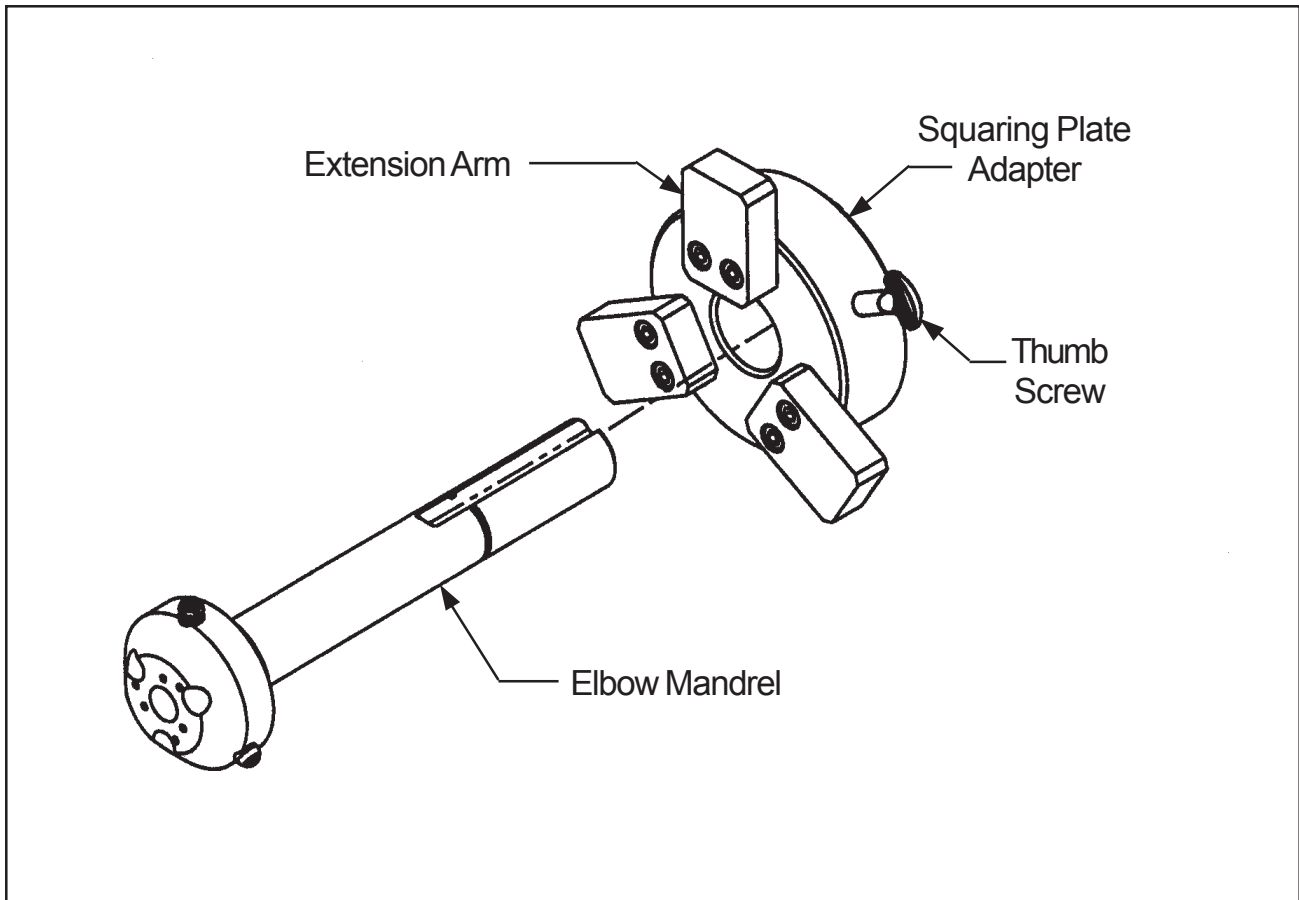

Slide the Squaring Plate Assembly over the back of the elbow mandrel shaft.

Tighten the thumb screw to secure the Squaring Plate Assembly to the elbow mandrel shaft.

Slide the Squaring Plate Assembly and elbow mandrel into the end of the elbow.

## Model 204B, 206B, 212B EM Squaring Plate Kits

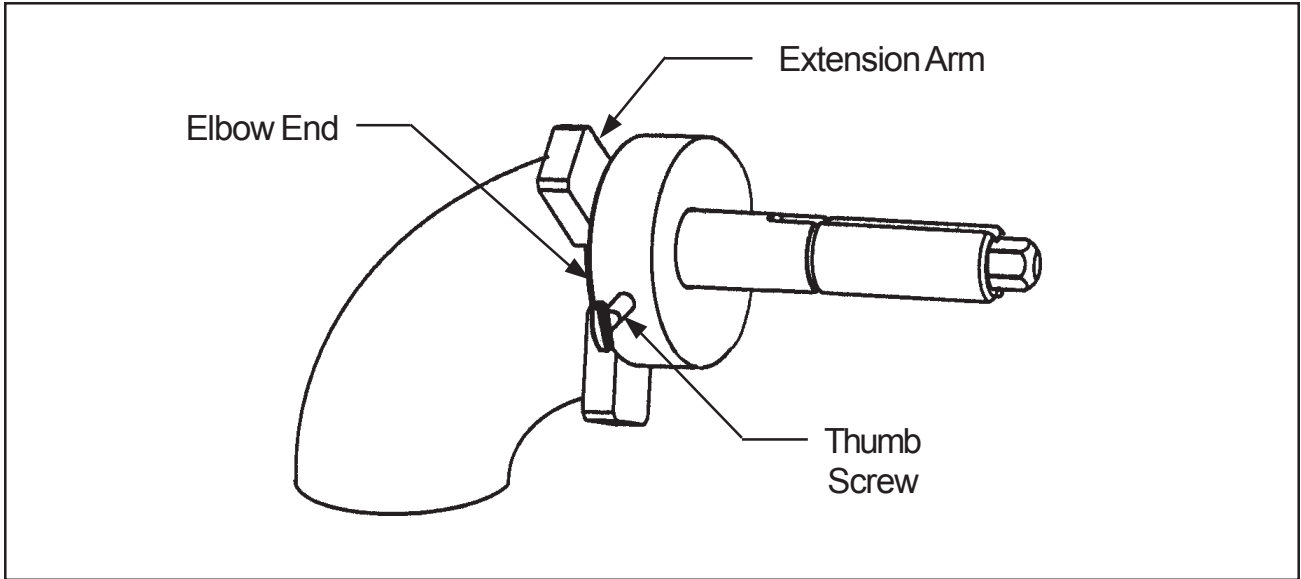

The (3) three extension arms should be in contact with the end of the elbow.

Turn the nut on the end of the elbow mandrel to extend the centering pins out to the elbow I.D.

Once the centering pins are tight against the wall, loosen the thumb screw.

Slide the Squaring Plate Assembly off of the mandrel.

The mandrel is now ready for the Model 200B to be mounted on to it.

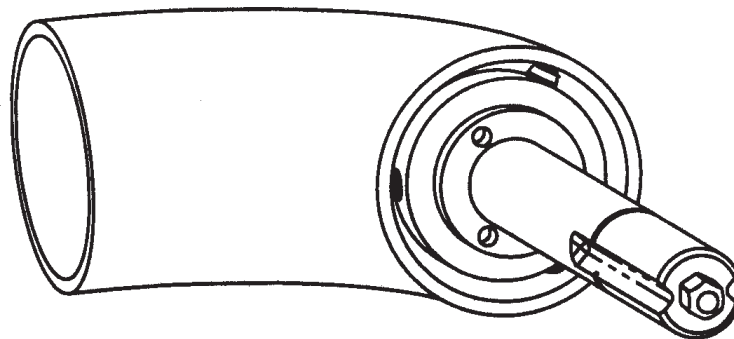

**ILLUSTRATED PARTS BREAKDOWN**

**204B SQUARING PLATE KIT (P/N 05-1330)**

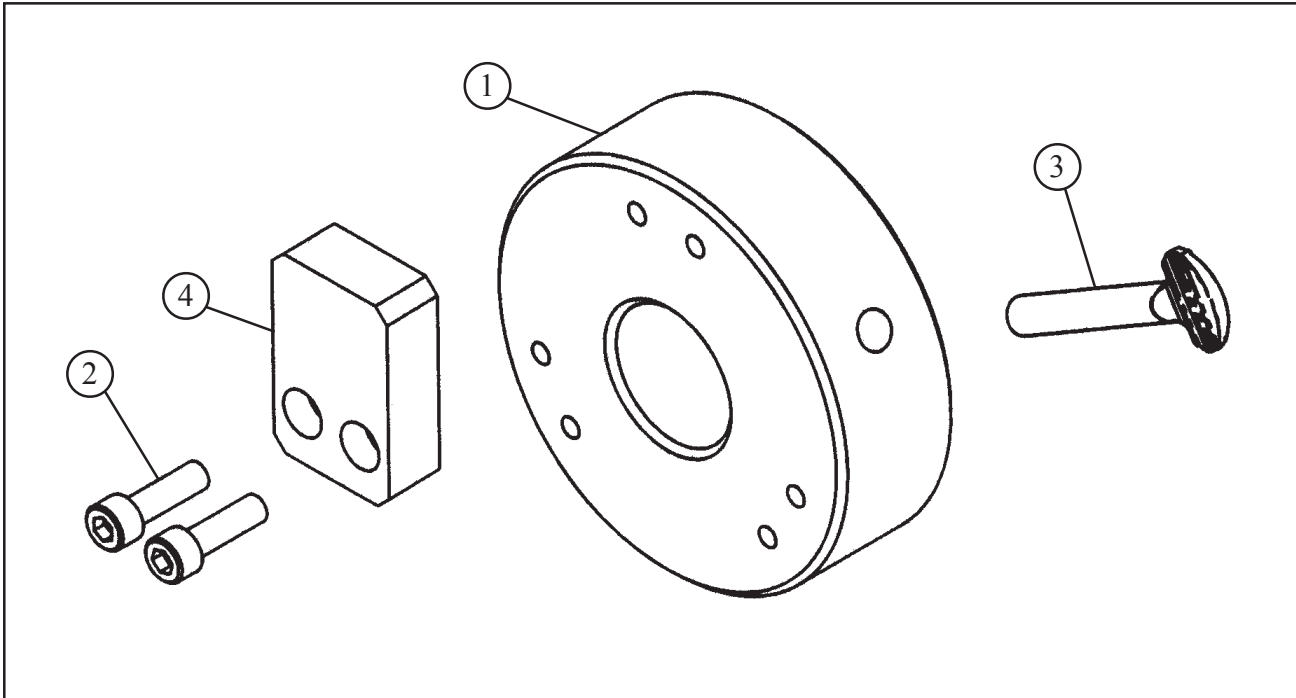

Parts List, 204B Squaring Plate Kit (P/N 05-1330)

Item No.	Part No.	Description	Qty
1.	27-0700	ADAPTER, SQ. PLATE, 204B	1
2.	33-0029	SCREW, CAP, #10-24 X 5/8"	6
3.	33-1750	SCREW, THUMB, BRASS, 1/4-20 X 1 1/2"	1
4.	63-0186	ARM, EXTENSION, 204B	3

206B SQUARING PLATE KIT (P/N 05-1328)

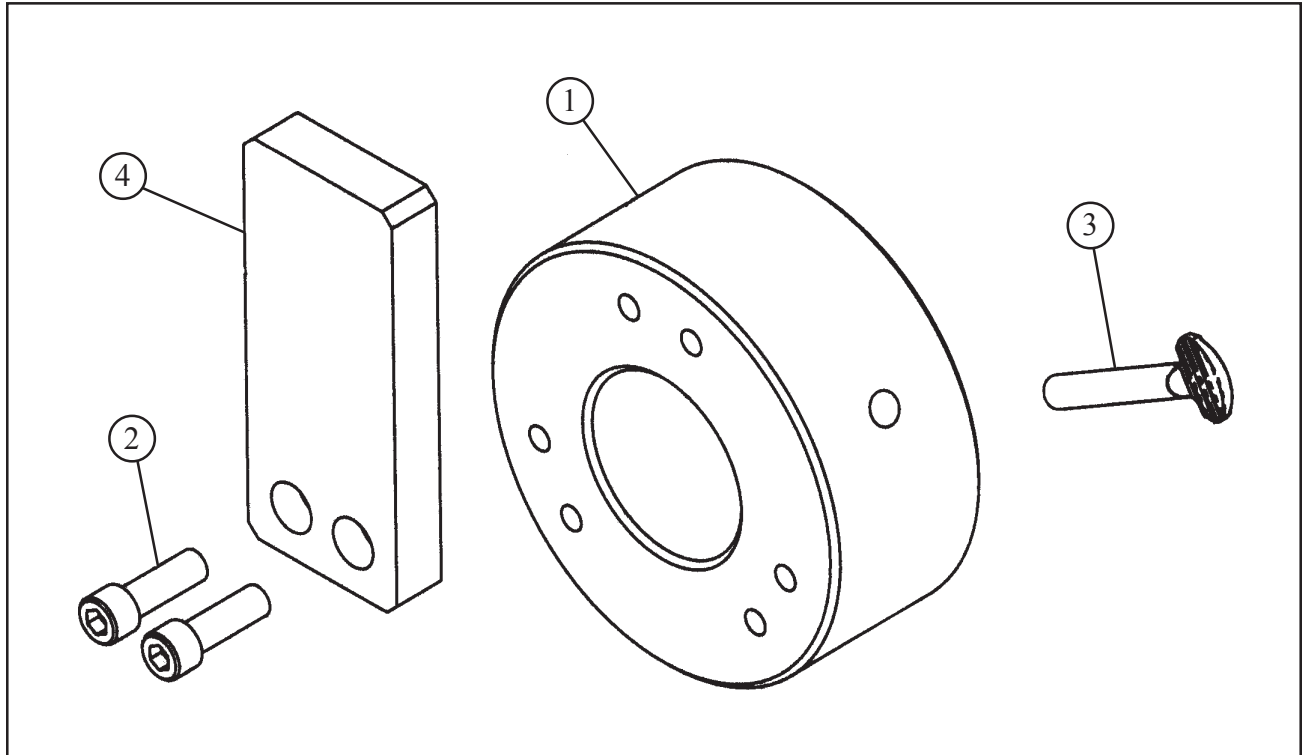

Parts List, 206B Squaring Plate Kit (P/N 05-1328)

Item No.	Part No.	Description	Qty
1.	27-0701	ADAPTER, SQ. PLATE, 206B	1
2.	33-0039	SCREW, CAP, 1/4-20 X 5/8"	6
3.	33-2253	SCREW, THUMB, BRASS, 1/4-20 X 2"	1
4.	63-0187	ARM, EXTENSION, 206B	3

212B SQUARING PLATE KIT (P/N 05-1329)

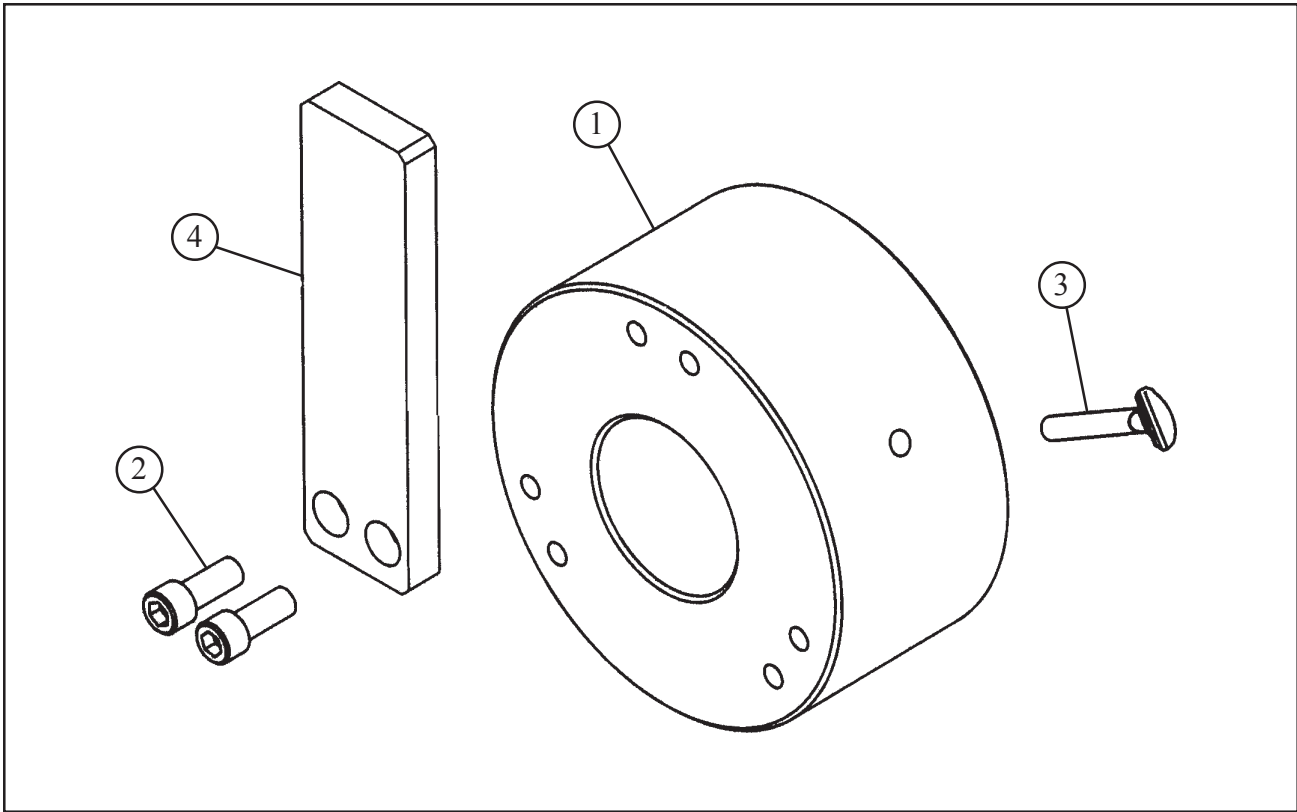

Parts List, 212B Squaring Plate Kit (P/N 05-1329)

Item No.	Part No.	Description	Qty
1.	27-0702	ADAPTER, SQ. PLATE, 212B	1
2.	33-0053	SCREW, CAP, 5/16-18 X 5/8"	6
3.	33-2253	SCREW, THUMB, BRASS, 1/4-20 X 2"	1
4.	63-0188	ARM, EXTENSION, 212B	3