

Bevel, Face, and Counterbore Elbows, Crosses, and Tee Fittings

Model 530 Fitting Machine

This bench tool simultaneously machines 1" (25.4 mm) to 4" (101.6 mm) fittings or pipe with fast accurate repeatability. It is useful in repiping or modifying end prep bevel angles, land thickness and counterbores. The Fitting Machine makes salvaging used fittings and pipe possible and very cost effective.

Position Adjustments:

Axis	Travel	Type
X	± 1.00"	screw thread
Y	+ 4.00"	manual
Z	± 1.00"	screw thread
rotary	360°	manual

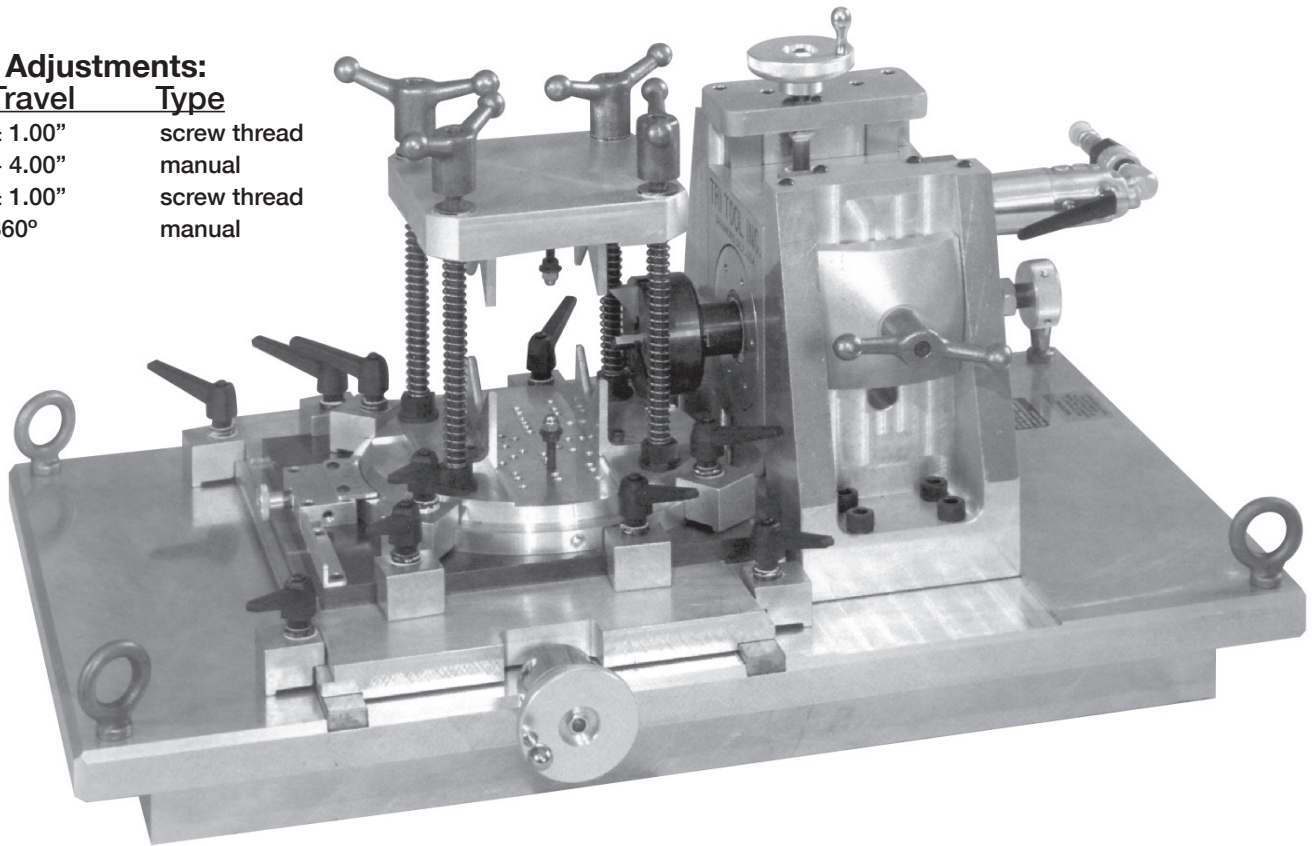

Cutting Capacities:

- 1" to 4" pipe as listed on all schedules
- Short radius 90° elbows
- Long radius 90° elbows
- Straight Tees
- Straight crosses
- Reducing outlet tees
- Reducing outlet crosses
- Short lengths of pipe
- Special fixturing capacity available

- Modular fixturing system accepts most fittings
- Rotating spindle head carries the bits
- Center and square fittings without disturbing bit settings
- Dial indicator can be used for extra precision
- Rotary table indexing for accurate angular relationships
- XYZ fitting positioning with locks at all adjustments
- Y axis depth stop
- Electric or pneumatic power options

Save time and money with dependable Tri Tool tube and pipe equipment!



TRI TOOL INC.

3806 Security Park Drive • Rancho Cordova, CA 95742
 (800) 345-5015 • (916) 288-6100 • Fax (916) 288-6160
 www.tritool.com

One year limited warranty

©Copyright Tri Tool Inc. All rights reserved.
 Printed in the USA PN-0 [1209]